



P.3 LITERACY ONE

REVISED LESSON NOTES

TERM

WEEK TWO

Lesson one

SOIL

Is a non- living component of the environment which is useful to plants, people and other living things.

Or soil is the top layer that covers the earth's surface.

How is soil formed?

Soil is formed by:

-**Weathering:** the breakdown of rocks to form soil.

-**Decomposition:** the rotting of plants and animals to form soil.

Components of soil

- Humus
- Rock particles
- Living organisms
- Air
- Water

ACTIVITY

1)How do we call the top layer that covers the earth's surface?

2)What is weathering?

3)Name three components of soil.

Lesson Two & three

EXPERIMENT TO SHOW THAT SOIL CONTAINS WATER

- Collect a lump of soil from a garden
- Put the soil into the sauce pan
- Put the sauce pan on fire
- Cover the sauce pan with a metallic lid/sauce pan.

Experiments to show that soil contains water

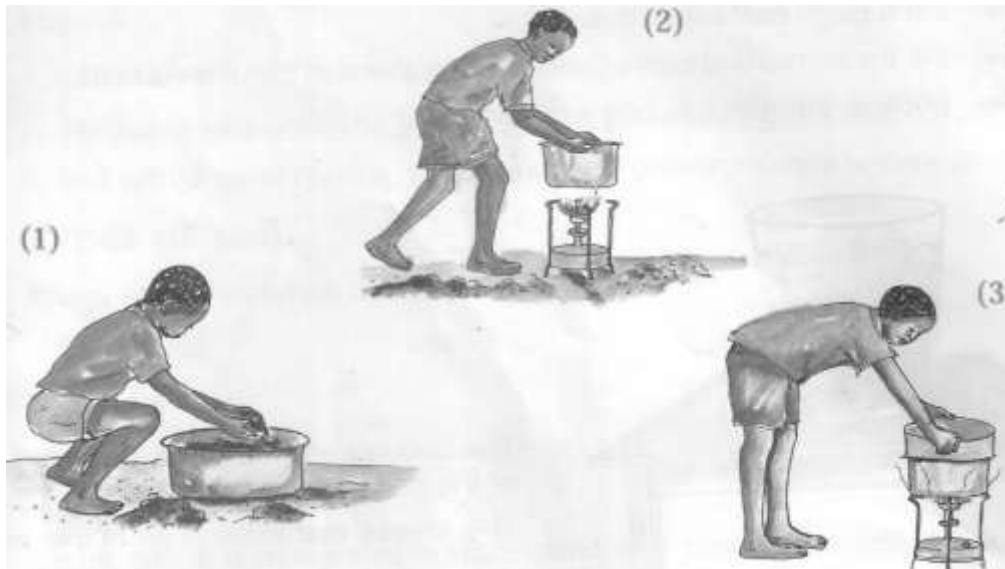

What do you observe?

Water droplets on cover come from water escaping from the soil in form of water vapour.

Conclusion

This shows that soil contains water.

ACTIVITY

1)What is does the experiment above show?

Lesson four & five

EXPERIMENT TO SHOW THAT SOIL CONTAINS AIR

- Fill a glass with half dry soil lump.
- Fill the remaining part with water and put it on a table.
- Look at the glass to see what happens.



Observation

Bubbles are seen coming out of the soil.

Conclusion

Bubbles show air escaping from the soil.

Uses air in the soil.

Helps livingthings in the soil to breathe.

Helps seeds to germinate.

Lesson six & seven

EXPERIMENT TO SHOW THAT SOIL CONTAINS HUMUS

- Get a big glass.
- Get some soil and put it in the glass.
- Add water to the glass.
- Now cover the glass, shake it and put it on a table.

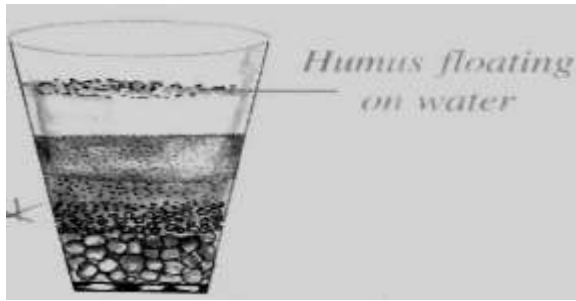

Observation

Black substances float on top of water.

Sand and gravel settle at the bottom.

Conclusion

The floating substance represents humus.

How is humus formed?

- When plants and animals die, they rot and form humus.

How useful is humus.

- Humus is very good food for proper growth of plants.
- Humus is dark and soft.

WEEK THREE

Lesson one

Types of soil

- Loam soil
- Sand soil
- Clay soil

Soil texture

This is the smoothness or roughness of soil

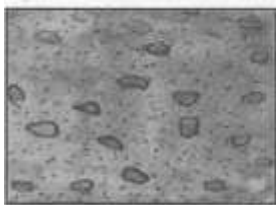

Loam soil



clay soil

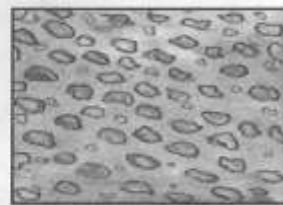

sand soil

ACTIVITY

- 1)Mention three types of soil.
- 2)Which soil has got the biggest particles?
- 3)Name the soil that has got the finest particles.

Which type of has both particles of clay and sand? **Loam soil**

Lesson two

Characteristics of loam soil

- Loam soil is a mixture of humus, sand and clay.
- It has medium – sized particles.
- It has good drainage that is, it holds enough water for the crops to use and grow well.
- It contains a lot of humus.
- It is properly aerated.

Uses of loam soil

For growing crops.

For making bricks

ACTIVITY

- 1)Name three components of loam soil.
- 2)Why is loam soil the best for crop growing?
- 3)Give one use of loam soil to people.

Lesson three

Characteristics of sand soil

- Has the biggest soil particles.
- It is loose, light and easy to dig.
- It contains a lot of air.
- It allows water to pass through it easily.
- It has less humus, so it's not fertile.
- It has the highest rate of drainage i.e. it dries quickly in hot weather.

Uses of sand soil

- For building houses
- For making blocks
- For making glasses
- For making sand paper

ACTIVITY

- 1)Why is sand soil not fertile?
- 2)Which type of soil allows water to pass through it easily?
- 3)Give two uses of sand soil to people.

Lesson four

Characteristics of clay soil

- It has the finest particles.
- It does not allow water through it easily.
- It is the best soil for pottery.

- It is poorly aerated.
- It is not good for plant growth because it water logs.

Uses of clay soil

- For pottery
- For making bricks
- For making tiles

ACTIVITY

- 1) Name the best soil for pottery.
- 2) Why is clay soil not good for plant growth?
- 3) Give two uses of clay soil.
- 4) Name two things at home that are made from clay.

Lesson five

Soil profile

- Soil profile is the vertical arrangement of soil layers.
- It is the arrangement of soil from top to bottom layers

Layers of soil

Top soil

Sub-soil

Gravel

Parent rock

Diagram of a soil profile

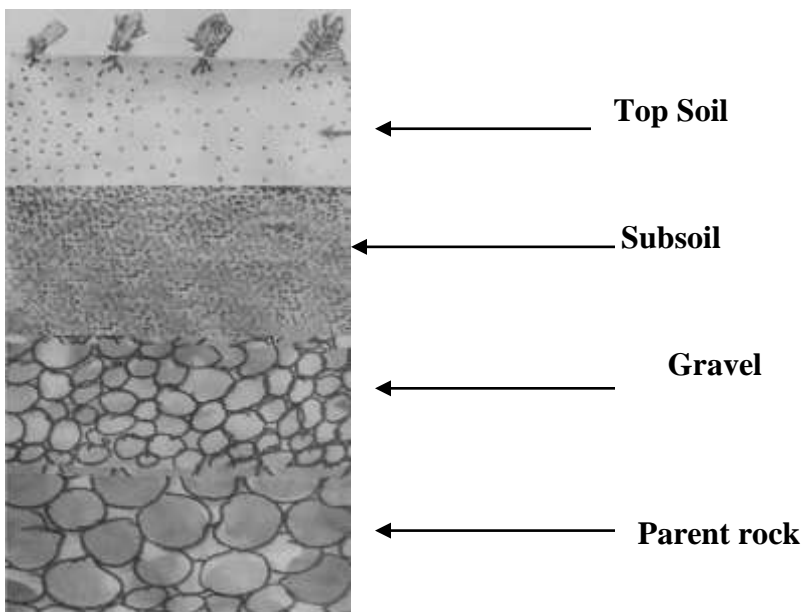

ACTIVITY

- 1) Define soil profile.
- 2) Name three layers of soil.
- 3) What is the top most layer of the soil profile?
- 4) Which layer of the soil supports plant growth?

Lesson six

Top soil

- It is the best layer for plant growth.
- It has a lot of humus.
- It is dark in colour.
- It is a layer where living organisms live.

Sub soil

- It is not a good layer for plant growth because it has no humus.
- It is a thick light brown layer.
- There are no living things.

ACTIVITY

- 1) What is the second layer of the soil profile?
- 2) Why is sub soil not a good layer for plant growth?
- 3) Why is top soil the best layer for plant growth?
- 4)

Lesson seven

Parent rock:

- It's a rock from which soil is formed.
- Has channels of water running through one rock another.
- The process by which rock breaks to form soil is called weathering.

Animals that live in soil:

- Moles
- Worms
- Termites
- Squirrels

- Bacteria

ACTIVITY

- 1)What is the bottom layer of the soil profile?
- 2)What is weathering?
- 3)List down any four animals that live in the soil.

WEEK FOUR

Lesson one

Soil erosion:

This is the washing away of top soil by its agents

Agents of soil erosion

- Running water.
- Strong wind.
- Animals.

Causes of soil erosion

- Over grazing.
- Cutting down trees (deforestation).
- Bush burning.
- Mono cropping.
- Drought.
- Over stocking
- Over cultivation
-

ACTIVITY

- 1)What is soil erosion?
- 2)Name the agents of soil erosion.
- 3)Give four causes of soil erosion.

Lesson two

Control of soil erosion

- 1) By mulching –the covering of top soil with dry plant materials.
- 2) By terracing
- 3)
- 4)

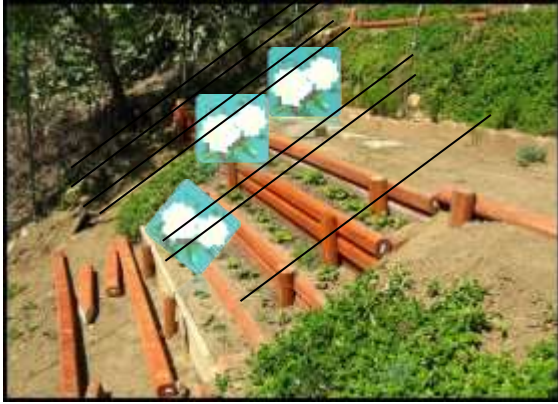

2) By terracing on hilly area

3) Contour ploughing.

4) Planting trees.

5) Planting grass on bare land.

6) Crop rotation.

7) Re a forestation – planting of trees where they were cut down.

ACTIVITY

1)Mention tree ways of controlling soil erosion.

2)How farmers in mountainous areas control soil erosion?

3)What is re-aforestation?

Lesson three

Mulching

.

Mulching- is the covering of top soil with dry plant materials.

Examples of mulches

- Dry grass
- Banana leaves

Coffee husks etc

Advantages of mulching:

- It keeps water in soil.
- It rots to form manure.
- Mulching prevents direct contact of top soil with strong winds / storms

Disadvantages of mulching

- It hides crop pests.
- Mulches are fire hazards.
- It is time consuming to lay mulches.

ACTIVITY

- 1)What is mulching?
- 2)Name three types of mulches.
- 3)Why do farmers mulch their gardens?Give two reasons.
- 4)Mention one disadvantage of mulching.

Lesson four

Effects of soil erosion:

- It causes desertification.
- It leads to famine.
- It leads to soil exhaustion.
- It creates unnecessary gulleys.

What is soil exhaustion?

Soil exhaustion is the loss of soil fertility.

Causes of soil exhaustion

- Over cultivation
- Over grazing
- leaching
- Bush burning

How to control soil exhaustion

- By mulching
- Use of crop rotation
- Addition of manure
- Use of fertilizers

ACTIVITY

- 1)Give two effects of soil erosion.
- 2)What is soil exhaustion?
- 3)State the causes of soil exhaustion.
- 4)Mention ways of controlling soil exhaustion.
- 5)Give two ways of controlling soil erosion.

Lesson five & six

Crop rotation

This is the growing of different crops on the same piece of land seasonally.

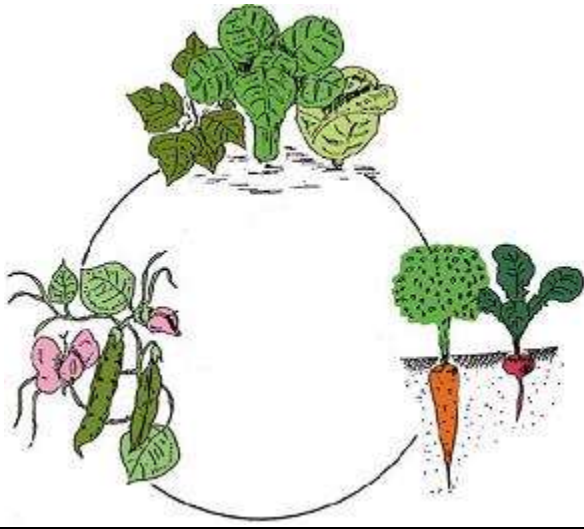

Advantages of crop rotation

- Controls soil erosion
- Improves on soil fertility
- Controls crop pests and diseases.

TOPICAL QUESTIONS

1) Give the three types of soil.

i _____

ii _____

iii _____

2) Write two components of from the list below:-

Water, soup, humus, cars living organisms, rock particles

I _____

II _____

III _____

IV _____

3) Show the four layers of soil on the diagram below

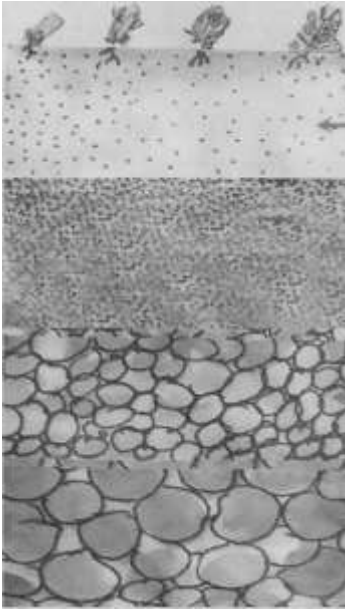

4) Collect a lump of soil put it into a sauce pan

Heat the soil with a metallic cover on top of the sauce pan

After some time, remove the cover



a. What do you see on the cover?

b. What does this activity show?

5) Get dry soil, water and put the two in a glass

a. What do you see?

b. What does this activity show?

6) Which layer of soil is good for plants to grow?

7) Use the diagram of soil collections to answer questions that follow.

A



B

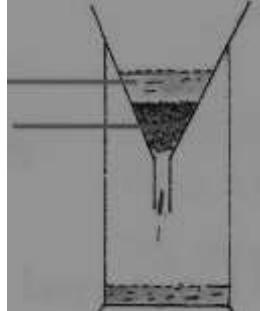

C

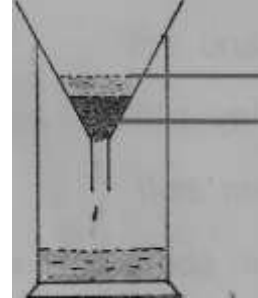

a. Which soil collection allowed a lot of water to pass through it?

b. Name the soil which allowed very little water to pass through it.

8) Write short sentences about how people use soil as shown in the diagram below



Lesson seven

Changes in our environment

Natural changes

Natural changes are changes brought about by nature and non-living things

Examples of natural changes in our environment.

- Earthquakes,
- hailstones
- floods,
- storms
- drought
- lightening
- landslide,
- thunder,

Natural changes in the sky

- The sun rises in the east and sets in th
- The sun is seen in the sky at day time and sets in the evening
- Wind blows from different directions
- Clouds appear in the sky
- The moon appears at night
- Floods are brought in by heavy rains

Effects of natural changes in our environment

- Hunger
- Soil erosion
- Migration ie the movement of people from one place to another.
- Diseases/ epidemics
- Destruction of homes and property
- Death

ACTIVITY

- 1)What are natural changes?
- 2)Mention natural changes in the environment.
- 3)Give three natural changes in the sky.
- 4)In which direction does the sun rise from?
- 6)At what time of the day does the moon appear in the sky?

WEEK FIVE

Lesson one

People-made changes

- These are changes brought about by man in our environment
- Examples
- Building homes
- Building houses
- Planting trees
- Making bridges
- Cutting down trees -deforestation
- Draining swamps
- Disposing wastes
- Burning bricks
- Making medicine from plants

Effects of people-made changes

Soil erosion

Easy transport

Accidents

Drought

Soil exhaustion
Death of animals
Spread of diseases
Desertification
Destruction of animal habitats

ACTIVITY

- 1) What are people-made changes?
- 2) Give four people-made changes in the environment.
- 3) Define deforestation?

Lesson two

Ways of managing changes.

- (a) Floods
 - (i) Dig big trenches to avoid floods
 - (i) Avoid cleaning swamps because they trap running water.
- (b) Drought
 - (i) Plant trees
 - (ii) Avoid clearing wet lands
 - (iii) Dig valley dams
 - (iv) Use irrigation method
 - (v) Avoid burning bushes
 - (vi) Proper farming methods e.g crop rotation, terracing, mulching.
 - (vii) Covering gullies with stones.
 - (viii) Educating people about dangers of cutting trees
 - (ix) Avoid throwing things that don't rot e.g plastic.

ACTIVITY

- 1) Give one way of managing floods in our environment.
- 2) Give two ways of managing drought.
- 3) Give any two proper farming methods.

Lesson Three

Simple project on tree planting.

Lesson four

Ways of managing changes continued

(c) Spoilt roads

- (i) Repair the roads
- (ii) Putting appropriate road signs to warn road users of any road damages
- (iii) Road signs

PHOTO COPY OF ROAD SIGNS

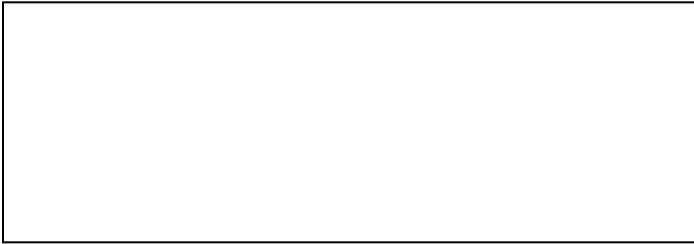

ACTIVITY

- 1) How can we manage spoilt roads in our environment? Give two ways.
- 2) Draw and name three road signs.

Lesson five

(d) Rusting of machines

Rusting, conditions for rusting and prevention

Rusting is a reddish coating that appears on metals.

-Conditions for rusting

- a) Oxygen
- b) moisture

Methods of preventing rusting

- a) By oiling
- b) By painting
- c) By greasing

- (i) Keep tools in a cool dry place
- (ii) Painting tools like wheel barrow and watering cans

ACTIVITY

- 1) Define rusting.
- 2) Give two conditions necessary for rusting.
- 3) Mention two methods of preventing rusting.

Lesson six

Accidents

(e) Causes of accidents

An accident is a sudden happening that causes injury or death.

Causes of accidents

- Over speeding
- Over loading
- Slippery roads
- Drunken drivers
- Vehicles in poor mechanical condition
- Careless pedestrians and cyclists
- Driving after taking drugs
- Over taking at wrong places

Control of accidents

- Keep, ride and walk carefully on the roads
- Follow traffic rules
- Use road signs
- Avoid over speeding
- Avoid over loading
-

ACTIVITY

- 1)What is an accident?
 - 2)Give three causes of accidents.
 - 3)Give two ways of controlling accidents on the road.
- (vii)

Lesson seven

Environment and weather in our division/ subcounty

Air and the sun

a) Air

- Air is a mixture of gases
- Moving air is called wind

Components of air

- Nitrogen 78%
- Oxygen 21%
- Rare gases 0.97 % (1%)
- Carbon dioxide 0.03% (0.04%)

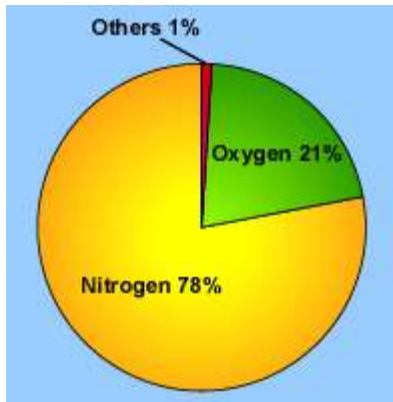

ACTIVITY

- 1) How do we call the mixture of gases?
- 2) Give two components of air.
- 3) What is the percentage of nitrogen in the atmosphere?

WEEK SIX

Lesson one

Properties of air

- Air has weight
- Air occupies space (has volume)
- Air can move things
- Air expands when heated
- Air can be compressed

Air has weight



ACTIVITY

- 1)Mention three properties of air.
- 2)Which property of air is shown above?
- 3)Which balloon appears on the lower side?
- 4)Draw the above property of air.

Lesson two

Air occupies space

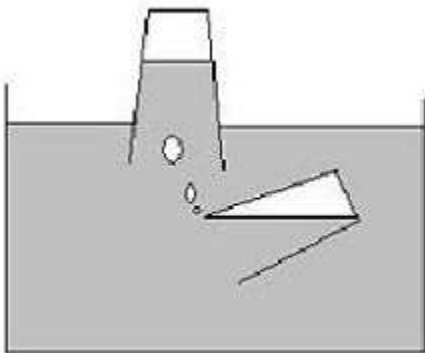

ACTIVITY

- 1)What is the experiment about?
- 2)What do air bubbles show?
- 3)Draw the above property of air.

Lesson three

Air exerts pressure

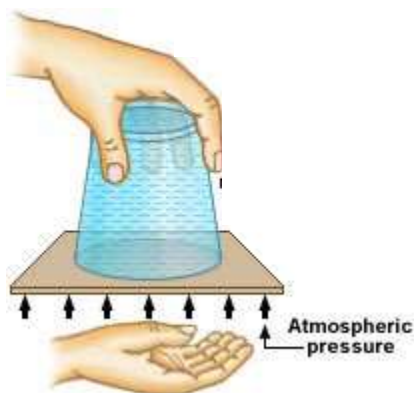

ACTIVITY

- 1)What is the experiment about?
- 2)Why did n't the water come out of the glass?
- 3)Draw the above property of air.

Lesson four

Air expands when heated

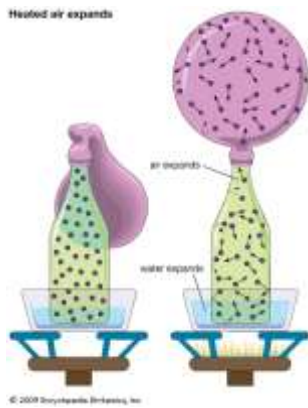

ACTIVITY

- 1)What is the experiment about?
- 2)What did you see before heating?
- 3)Draw the above property of air.

Lesson five

Air can be compressed



ACTIVITY

- 1)What is the experiment about?
- 2)Which property of air is used to inflate car tyres?
- 3)Draw and name three objects to show that air can be compressed.

Lesson six

Importance/uses of air

- Air supports burning (oxygen).
- Air is used for transport (Aeroplanes).
- Wind is a source of power to drive wind mills.
- Air is used in germination (oxygen).
- Carbon dioxide is used to preserve drinks.
- Air is used in winnowing seeds.
- Butane gas is used in gas cookers.
- Air is used by birds to fly.
- Wind helps in crop pollination.
- Wind helps in seed dispersal
- Animals breathe in air.
- Moving air helps to cool our bodies.
- Wind sails boats/ships/paper kites.
- Carbondioxide is used in fire extinguishers
- Wind is used for flying kites

Places where we find fire extinguishers

- Petrol stations
- Schools
- Hospitals
- Banks
- Hotels

- Homes
- Cars

ACTIVITY

- 1)Name the type of air used in preserving food.
- 2)Which type of air supports burning?
- 3)Give three uses of air.
- 4)Name the gas used in fire extinguishers.

5)Mention 4 places where we find fire extinguishers.

Lesson seven

Dangers of strong winds

- Strong wind carries away top soil.
- strong winds break boats/ ships on water (destroy property)
(They break down crops and house).
- Wind spreads diseases e.g flu, measles mumps/tubercnlosis etc.
- Wind raises dust, spoiling our eyes and environment as well.
- Strong wind blow off people's houses
- Strong winds can capsize boats

ACTIVITY

- 1)What do we call moving air?
- 2)Mention two diseases spread by air.
- 3)Give three dangers of wind to people.

WEEK SEVEN

Lesson one

b)The sun

- Biggest star.
- Hottest star.
- It rises from the east every morning.
- The sun sets in the west every evening.
- The sun produces a lot of heat.
- It also produces light

Uses of the sun (importance of the sun)

- The sun provides heat.
- The sun provided light.
- The sun's heat dries clothes/seeds.
- It is a source of solar energy.
- Sunlight is used during photosynthesis.
- The sun helps in formation of rainfall.
- The sun helps living things to grow.
- The sun helps our bodies to make vitamin D

Lesson two

Dangers of the sun

- Too much sunshine dries crops in the garden.
- Too much sunshine dries water bodies.
- Too much sunshine leads to drought.
- Sunny weather makes animals thirsty.
- Strong sunshine has rays which can cause skin cancer.
- The sun spoils our eyes if you look at it directly.

ACTIVITY

- 1)Name the hottest star.
- 2)Where does the sunrise from?
- 3)Name the type of vitamin we get from the sun?
- 4)Name the source of energy got from the sun.
- 5)Give two uses of sun.

Lesson three

- Shadows and opaque objects

What is a shadow?

A shadow is a dark shape formed when light is blocked by an opaque object.

What is an opaque object?

An opaque object is an object that does not allow light to pass through.

- Shadows are longer in the morning and evening.
- Shadows are shorter at mid-day and noon.

Importance of shadows in our environment

- Tells time
- Gives us shade

A shadow in the morning



A shadow at noon



A shadow in the evening



ACTIVITY

- 1)What is a shadow?
- 2)What are opaque objects?
- 3)Give one use of shadows to people.
- 4)When is the shadow of an object shorter?

Lesson four

TOPICAL QUESTIONS

- 1)Draw and name any three properties of air.
- 2)Which part of air supports burning?
- 3)Why is carbondioxide used to put out fire?
- 4)Where will a shadow of a person be when the sun is in the west?
- 5)Name two things that can be moved by air.
- 6)Give two dangers of wind.
- 7)Give two uses of sun to
 - a)people
 - b)plants
- 8)Where does the sun rise from?
- 9)What causes day and night?
- 10)Name two types of clouds.

- 11)What do we call dark clouds that bring rain?
- 12)What is the main natural source of water?

Lessen five

WATER

a) How rain is formed:

Water/rain cycle

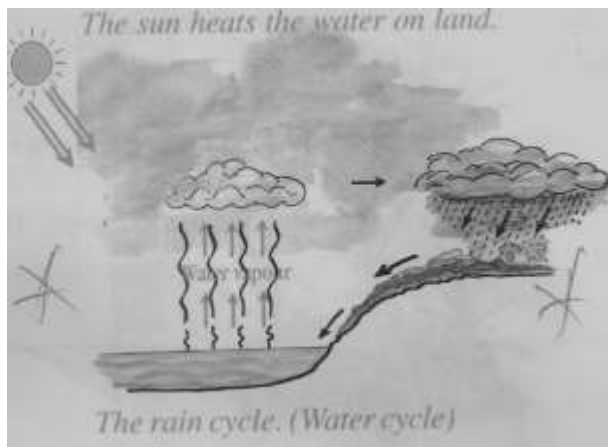

The sun **heats** the water body

Water **evaporates** to form water vapour

Water vapour rises and **condenses** to form nimbus clouds

Clouds become heavy, lower down and **melt** to form rainfall

ACTIVITY

- 1)What is the use of sun in the rain cycle?
- 2)Which clouds give us rain?
- 3)Name the processes that take place in the rain cycle.
- 4)In four sentences, explain how rain is formed.

Lesson six

RAIN (Formation of raindrops)

Rain is the main natural source of water.

Rain is formed from clouds.

Importance of rain

- Rain provides water for drinking.
- For washing.
- For watering plants.

- For softening soil to ease plant growth.
- Rainfall washes away dust from air
- It cools down temperature.
- It reduces dust on murrum roads.

watering plants



Water for drinking



ACTIVITY

- 1) Identify the main natural source of water
- 2) Give four uses of rain to plants and animals.
- 3) In which season do farmers plant their crops?

.

Lesson seven

Dangers of heavy rainfall

- Leads to soil erosion.
- Lightning can strike people and other animals.
- It breaks down houses and crops.
- It leads to floods.
- It makes murrum roads muddy

Solutions to the above problems

- By practicing better methods of farming

- By putting lightning conductors on the roofs
- Planting trees to act as wind breaks
- To avoid swamp drainage
- Tarmacing roads
- ACTIVITY
-
- 1)Give three dangers of rain rainfall.
- 2)Mention ways of controlling :
- Soil erosion
- Floods
- \
- -0Lightning

WEEK EIGHT

Lesson one

CLOUDS

There are four types of clouds namely:-

- Nimbus clouds



- Cirrus clouds
- Stratus clouds
- Cumulus clouds

NOTE PHOTO COPY TYPES OF CLOUDS



Cirrus - are the furthest/highest clouds.

Stratus - clouds are commonly dark grey and sometimes cause drizzles.

Cumulus clouds commonly white in colour.

Cumulo - nimbus clouds – bring rain/storms.

Nimbus clouds - bring steady rainfall.

ACTIVITY

1) Which clouds bring steady rainfall?

2) Name the clouds that cause drizzles.

3) Mention the highest clouds

Lesson two

How clouds affect the environment:

- Nimbus clouds bring steady rains.
- A cloudy weather brings a low temperature.
- Cumulus clouds bring a clear day

Dangers of clouds

- They cause lightning
- They bring heavy rain fall which cause floods
- Clouds cause accidents to people who use air transport.

ACTIVITY

1) Mention two effects of clouds to the environment.

2) Give two dangers of clouds to people.

.

Lesson three

How rain is measured

- A rain gauge is the weather instrument for measuring rain.

ACTIVITY

-Name the different parts of a rain gauge.

-Give the functions of the different parts of the rain gauge

-Draw and colour a rain gauge.

-Where should a rain gauge be placed?

-Why is a rain gauge important to a farmer?

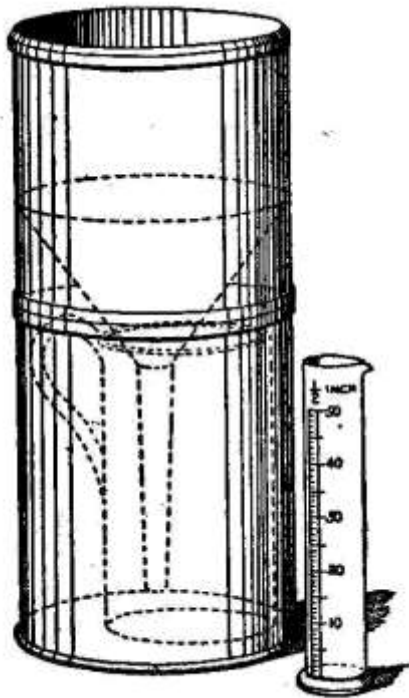

FIG. 151.—Standard rain-gauge.

Lesson four

Other natural sources of water

- Lakes
- Streams
- Rives
- Oceans

Artificial sources of water.

- Bore holes
- valley dams
- Ponds
- springs

ACTIVITY

- 1)Name the main natural source of water.
- 2)Identify two other natural sources of water.
- 3)Mention two artificial sources of water.
- 4)Name the instrument used to measure rainfall.
- 5)Identify two ways of harvesting water.
- 6)Mention two ways of maintaining water sources.

Lesson five

Managing Water

1) Importance of water

To people

-For cooking

-For washing clothes

-For drinking

-For washing utensils

To plants

-It helps plants to make their own food

-It helps the seeds to germinate

ACTIVITY

1) Give three importance of water to people

2) Mention two uses of water to plants

Lesson six

.

Water harvesting

Water can be harvested by using

-Tanks

-Buckets

-Basins

-Digging valley dams

-Jerrycans

Maintenance of water sources

Repairing the damages

Fencing the water sources

Cleaning water sources

Avoid dumping wastes in water sources

Lesson seven

TOPICAL QUESTIONS

- 1)Name any three types of cloud.
- 2)Identify the main natural source of water.
- 3)In which season take place?
- 4)Name two ways in which people can control floods.
- 5)Identify two ways of harvesting water.
- 6)Give two uses of water to plants.
- 7)Name the instrument used to measure rainfall.
- 8)Mention three ways of maintaining water sources.