

P530/1
BIOLOGY
Paper 1
AUGUST, 2024
2½ hours

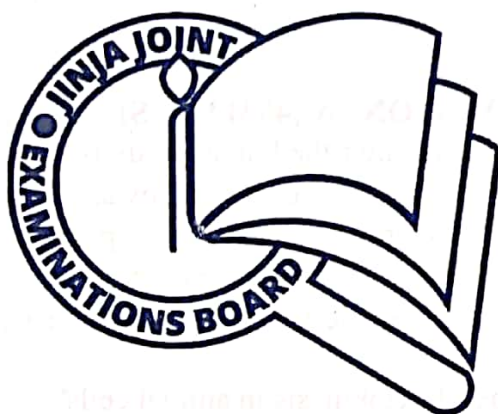

JINJA JOINT EXAMINATIONS BOARD

Uganda Advanced Certificate of Education

MOCK EXAMINATIONS – AUGUST, 2024

BIOLOGY

Paper 1

2 hours 30 minutes

INSTRUCTIONS TO CANDIDATES

Answer all questions in both sections A and B.

SECTION A:

Answers to this section must be written in the answer sheet provided at the end of this section.

SECTION B:

Answers to this section should be written in the spaces provided and not anywhere else.

No additional sheets of paper should be inserted in this booklet.

For Examiner's Use Only

SECTION	MARKS
Section A: 1 – 40	
Section B: 41	
42	
43	
44	
45	
46	
TOTAL	

.....
© 2024 Jinja Joint Examinations Board

Turn Over
.....

SECTION A (40MARKS)

1. The initial response when bacteria enter the human body is
- A. Non-specific response and bacteria are destroyed by antibodies
- B. Non-specific response and bacteria are destroyed by phagocytes
- C. Specific response and bacteria are destroyed by antibodies
- D. Specific response and bacteria are destroyed by phagocytes
2. Which of the following is true of cytokinesis in animal cells?
- A. Cell structures replicate
- B. Cleavage furrow forms between nuclei
- C. Nuclear envelop reforms
- D. Spindle fibres disintegrate
3. The component of an animal's nervous system that provides the instruction for carrying a particular fixed action pattern is called a
- A. Innate releasing mechanism
- B. Exogenous biological clock
- C. Response chain
- D. Sign stimulus
4. Wearing a coarse shirt causes tickling sensation but the sensation disappears. Which of the following is not an explanation of this observation?
- A. Supply of transmitter substances get exhausted
- B. The membrane surrounding the generator becomes less permeable to sodium ions
- C. The discharge of impulses at the afferent nerve stops
- D. Generator potential falls below threshold value
5. The diagram below shows an embryo sac from a mature ovule. Which part will fuse with male gamete to form a triploid nucleus?

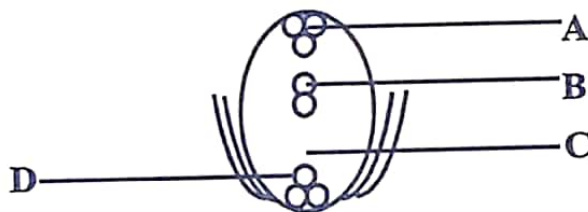

6. Which type of nutrition is found in purple sulphur bacteria?

- A. Photoheterotrophic nutrition
- B. Chemoheterotrophic nutrition
- C. Photoautotrophic nutrition
- D. Chemoautotrophic nutrition

7. Which of the following pairs of organisms have a cephalothorax?

- A. Crustaceans and diplopods
- B. Arachnids and chilopods
- C. Insects and arachnids
- D. Arachnids and crustaceans

8. Red blood cells have a diameter of 7000 nm. Pancreatic cells have a diameter of 35 μm . What is correct about the relative sizes of these cells?

- A. The red blood cells are 5 times larger.
- B. The red blood cells are 50 times larger.
- C. The red blood cells are 5 times smaller.
- D. The red blood cells are 50 times smaller

9. In which of these organelles is ATP synthesized?

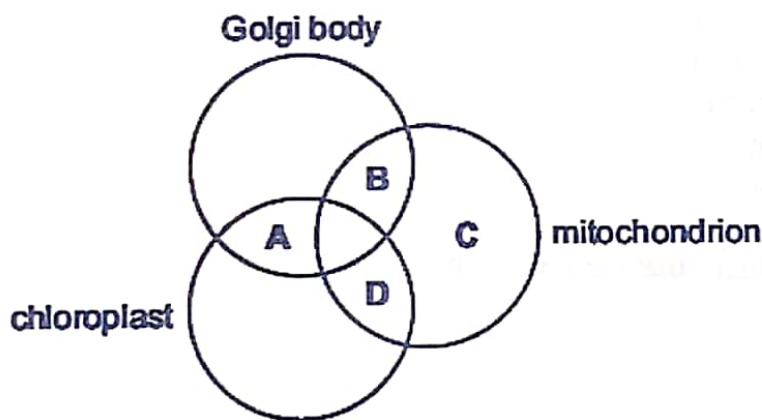

10. Genes P, Q, R and S are located on the same chromosome. The cross over values between them are; P-Q 24%, R-P 14%, R-S 8% and S-P 6%. What is the sequence of genes on the genetic map of the chromosome?

- A. PRSQ
- B. RSPQ
- C. RPQS
- D. QRSP

11. Which one of the following would be the immediate problem to a fish when taken out of water?

- A. Lack of food
- B. Insufficient oxygen supply
- C. Drying up of gills
- D. Lack of support

12. Which one of the following correctly describes the state of the muscles in earth worm in a region of the body that is being moved forward?

- A. Circular muscles are contracted and longitudinal muscles relaxed
- B. Both circular and longitudinal muscles relaxed
- C. Both circular and longitudinal muscles contracted
- D. Circular relaxed and longitudinal muscles contracted

13. What does a phenotypic ratio of 3:1 in a dihybrid genetic cross indicate?

- A. Dominance
- B. Failure of homologous chromosomes to separate
- C. Crossing over of chromosomes
- D. Linked genes

14. The phenomenon in which two or more alleles in a population are maintained at levels above those that can be accounted for by mutation alone is

- A. Heterozygous advantage
- B. Genetic polymorphism
- C. Industrial melanism
- D. Stabilizing selection

15. The larval stage of liver flukes that encysts on the blades of grass is called

- A. Miracidium
- B. Redia
- C. Sporocyst
- D. Cercaria

16. Most of the absorption of the products of digestion in humans takes place across

- A. Ciliated epithelial tissue
- B. Squamous epithelial tissue
- C. Columnar epithelial tissue
- D. Cuboidal epithelial tissue

17. The graph shows how the rate of photosynthesis varies with light intensity at two different temperatures. Other variables are kept the same.

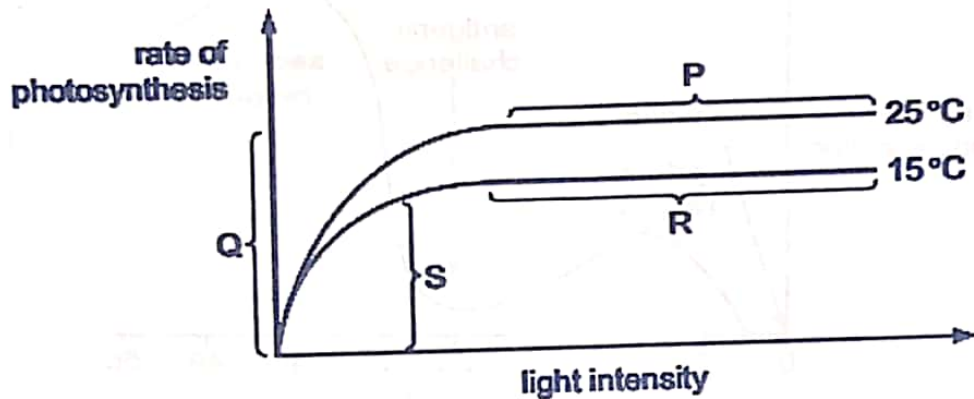

In which sections of the graph is light intensity limiting the rate of photosynthesis?

- A. P and R
B. Q and S
C. R and Q
D. S and P

18. Which statement correctly describes the transcription of DNA?

- A. It is a semi-conservative process.
B. It occurs at the surface of the ribosome.
C. It produces messenger RNA.
D. It produces polypeptides.

19. A rat in a box learns to associate pressing a lever with obtaining food demonstrates

- A. Classical conditioning
B. Habituation
C. Operant conditioning
D. Imprinting

20. Chemical messengers used for communication within a given animal species are called

- A. hormones
B. genes
C. pheromones
D. prostaglandins

21. The graph shows the level of antibody in serum following vaccination and a challenge with the same antigen 28 days later.

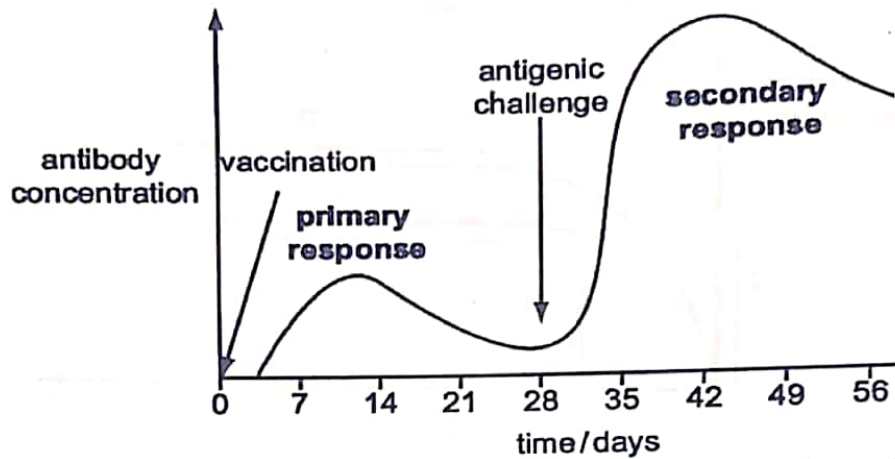

Which cells account for the difference in antibody concentration at the peaks of the primary and secondary responses?

- A. B-lymphocytes
- B. memory cells
- C. phagocytes
- D. T-lymphocytes

22. In a healthy mammal, which one of the following will lead indirectly to increased production of glycogen in liver cells?

- A. stimulation of the adrenal medulla
- B. a reduction in the amino acid concentration in the blood
- C. a reduction in insulin output
- D. a high glucose content in the diet

23. Which of the following would bring about wound healing if a plant is damaged?

- A. Cytokinins
- B. Gibberellins
- C. Abscisic acid
- D. Ethene

24. If a plant cell with a water potential of -700kPa is placed in each of the following solutions. In which solution will the plant cell be at incipient plasmolysis?

- A. Solution P = -650 kPa
- B. Solution Q = -950 kPa
- C. Solution R = -450 kPa
- D. Solution S = -400 kPa

25. The promotion of flowering by exposure to low temperatures for a period of time is known as
- A. thermotropism
 - B. dominance
 - C. vernalisation
 - D. photoperiodism
26. How do the fresh water fish like tilapia avoid osmotic influx of water across the exposed partially permeable surface of the body.
- A. Have smaller glomeruli
 - B. Chloride excretory cells in gills actively expel salts
 - C. Excrete trimethylamine oxide
 - D. Have many glomeruli
27. Which of these ions are abundant in the sarcoplasmic reticulum?
- A. Calcium
 - B. Magnesium
 - C. Sodium
 - D. Potassium
28. Which one of the following is not shown by a parasite that is well adapted to its mode of life
- A. Using more than one host
 - B. Killing the host
 - C. Inflicting moderate harm to its host
 - D. Using an intermediate host
29. Which one of the following may explain why plants cannot use ATP produced during light reactions of photosynthesis as the only source of energy?
- A. Needs more ATP for phosphorylation of GP
 - B. ATP cannot be produced in cells lacking chlorophyll
 - C. ATP can easily be transported out of photosynthetic cells
 - D. ATP can only be produced by light reactions in plant cells
30. Which of these bones is not part of the axial skeleton?
- A. Clavicle
 - B. Skull
 - C. Sternum
 - D. Ribs

31. Passage of ova through the female reproductive tract is facilitated mainly by

- A. Amoeboid movement
- B. Ciliary movement
- C. Muscular movement only
- D. Pseudopodial movement

32. A person on a long hunger strike, surviving only on the water will have

- A. Less amino acids in urine
- B. More sodium in urine
- C. Less urea in urine
- D. More glucose in urine

33. If a mother fails to produce milk in her breasts at the birth of her baby. Which part of the brain in the head of the mother is affected?

- A. Cerebellum
- B. Posterior lobe of the pituitary gland
- C. Pineal body
- D. Anterior lobe of the pituitary gland

34. Which one of the following factors would contribute least to the development of a new species?

- A. Environmental stability
- B. Geographical isolation
- C. Gene mutation
- D. Chromosomal mutation

35. The bacteria that converts nitrates to nitrites during the nitrogen cycle are an example of

- A. Denitrifying bacteria
- B. Decomposing bacteria
- C. Nitrogen fixing bacteria
- D. Nitrifying bacteria

36. The mycorrhizae on some plant roots serve to

- A. Fix nitrogen from the atmosphere
- B. Absorb mineral salts from the soil
- C. Breakdown humus
- D. Synthesize carbohydrates

37. Fast-twitch fibres in atheletes are adapted to their roles by having
- A. Large store of myoglobin and much cytochrome pigments
 - B. Slow graded contraction of long duration
 - C. Depend on aerobic respiration for ATP production
 - D. Abundance of glycogen granules

38. From a fish pond, 140 tilapia fish were collected, marked and released into a fish pond. After one week, 200 fish were collected from the same pond and 34 of them carried the mark. The estimated number of fish in the pond is

- A. 824
- B. 659
- C. 23240
- D. 4760

39. Totally submerged hydrophytes usually have
- A. Thicker cuticles on leaves
 - B. Smaller leaves with dissected lamina
 - C. Stomata confined to underside of leaf
 - D. Epidermal hairs on leaf lamina

40. During human embryonic development the mesoderm germ layer gives rise to development of

- A. Muscles, blood and skeleton
- B. Gut, muscles and skeleton
- C. Skin, muscles and gut
- D. Neural tube, blood and skin

SECTION B (60 MARKS)

41. The contents of an animal's stomach were removed via an opening known as fistula. The contents were removed after a meal.

The graph shows the relative levels of pepsinogen, substance X and pH

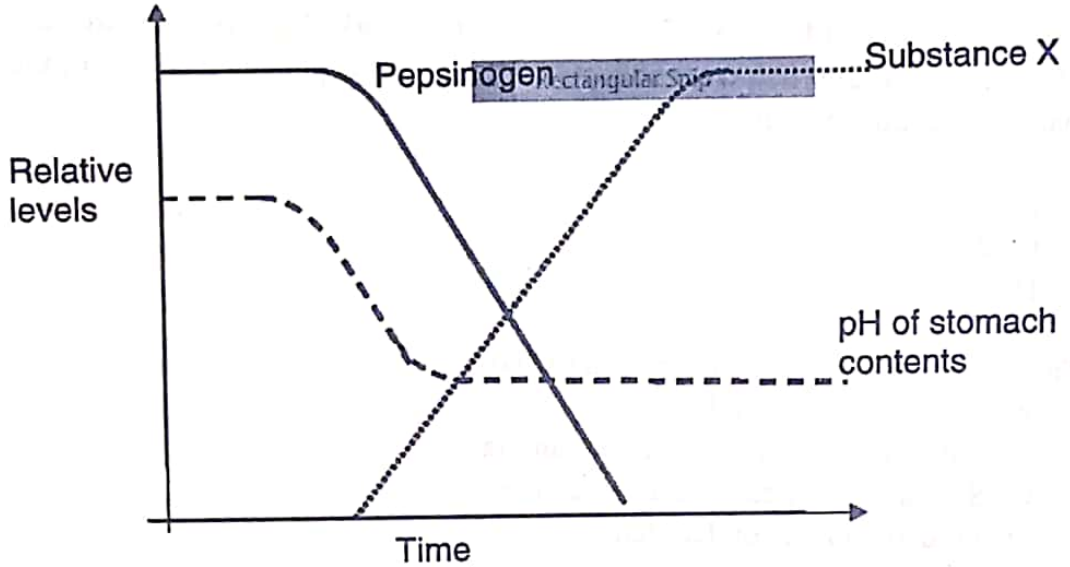

(a) Explain why the pH fell as a result of the meal entering the stomach (02 marks)

.....
.....
.....
.....

(b) (i) Suggest why the level of pepsinogen fell (03 marks)

.....
.....
.....

(ii) Name substance X (01 mark)

.....

(c) Describe the role of bile juice in lipid digestion and its absorption (04 marks)

.....

.....

.....

.....

.....

.....

.....

42. (a) Describe how natural defence mechanisms prevent the entry of disease causing organisms in the body. (06 marks)

.....

.....

.....

.....

.....

.....

.....

(b) Describe how fibrinogen protects the body from disease. (04 marks)

.....

.....

.....

.....

.....

.....

.....

44. (a) Give two reasons why maintaining a constant blood glucose concentration is important in man? (02 marks)

.....
.....
.....
.....

(b) Explain how the formation of glycogen in the liver cells leads to lowering of blood glucose concentration. (02 marks)

.....
.....
.....
.....
.....
.....
.....
.....

(c) Explain why glucose appears in urine of diabetic individuals. (02 marks)

.....
.....
.....
.....
.....
.....
.....
.....

45. (a) Explain the meaning of the term primary succession. (02 marks)

.....
.....

(b) Explain the role of pioneer plants in succession on a bare rock. (03 marks)

.....
.....
.....
.....
.....

(c) Suggest two ways in which deflected succession in any given ecosystem could be caused. (02 marks)

.....
.....
.....
.....

(d) Explain how biomass changes during a primary succession. (03 marks)

.....
.....
.....
.....

46. The figure below shows the blood pressure, blood velocity and cross sectional area of different types of blood vessels.

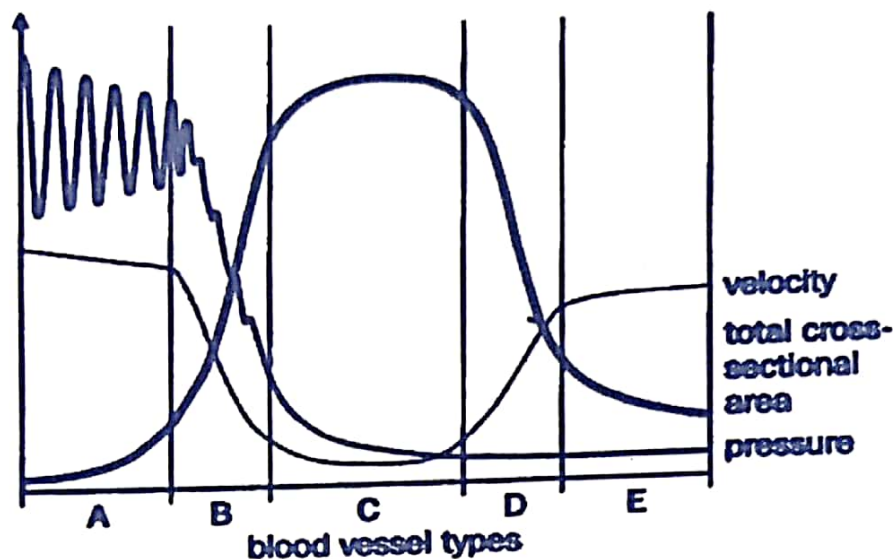

(a) Identify:

(i) Blood vessels A, B, C, D and E

(2½ marks)

.....

.....

.....

(ii) With a reason, which of these blood vessels has the highest proportion of muscle tissue in its wall?

(1½ marks)

.....

.....

.....

(b) Account for:

(i) The variations in blood pressure shown in vessels type A (2½ marks)

.....
.....
.....
.....

(ii) The rapid drop in blood pressure in vessel type B (01 mark)

.....
.....
.....
.....

(iii) The increase in blood velocity in vessel types D and E when the blood pressure is low. (1½ mark)

.....
.....
.....
.....

(c) Suggest the significance of the relationship between blood velocity and cross-sectional area of vessel type C. (01 mark)

.....
.....