

Katikamu SDA SS O'level physics seminar on 23rd June 2024

Item 1

A businessman who sells boiled eggs has decided to buy a solar system since he has been spending a lot of money on the purchase of charcoal. He has decided to go to the local shop which deals in solar systems. He has found two types of solar panels and he has completely failed to choose the best to use for boiling the water for his business.

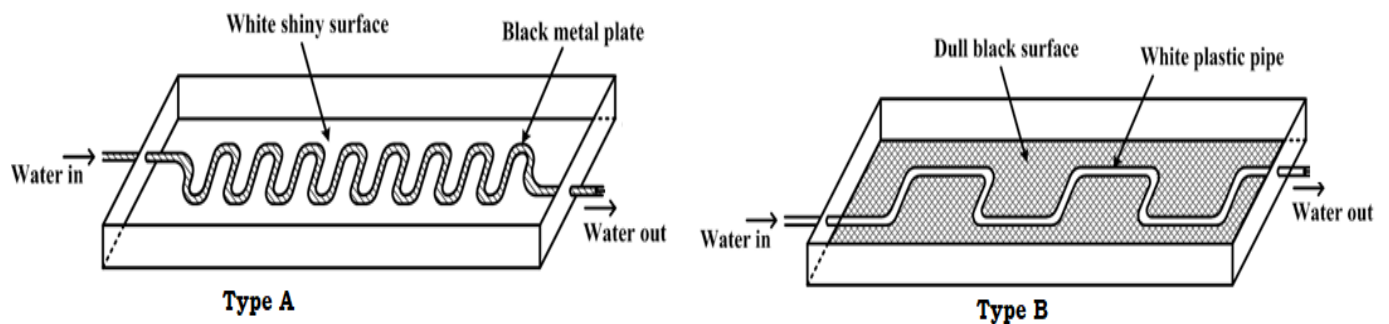

The panel is to be placed on the top tray of the metallic frame. The frame will then be placed on the top of the iron sheeted roof. All its iron sheets can withstand a pressure of 150,000 Pa without getting damaged by the pressure exerted by the weight of the frame and the solar panel.

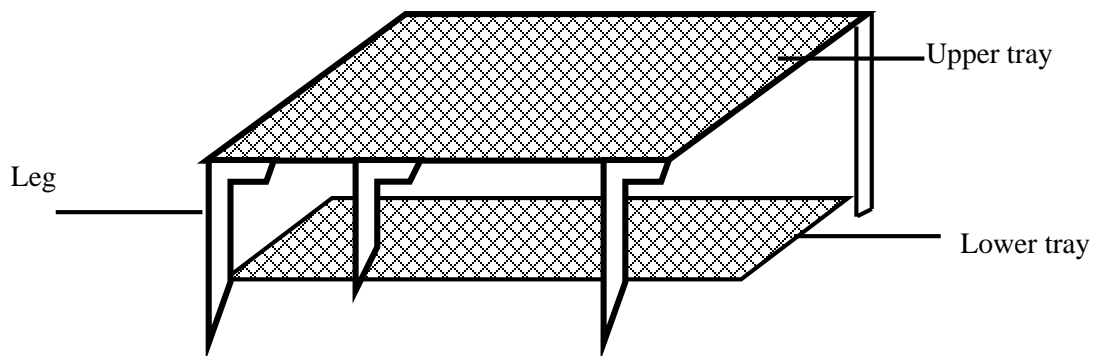

Hint: The total weight of the frame and the solar panel is 10 kg.
Acceleration due to gravity is 10 ms^{-2} .
Total area of contact of the four legs of the metallic frame is 5 cm^2 .

As a physics student

- (a) Advise the businessman on the best type of the solar panel to buy by comparing the two types of solar panels.
- (b) Help him find out whether his iron sheets will remain safe if the frame and the solar panel are placed on it.
- (c) Suggest the ways of maintaining the frame on top of the roof without getting blown away by wind.
- (d) Sensitise the businessman on the advantages of using solar energy over other sources of energy.

Item 2

After selling part of his harvest, the farmer decided to buy a big radio set with specification on it of 100 V, 5A and 50 Hz which he does not interpret. At his home, electricity from the national grid is supplied at 240 V and 5A. The radio failed to work which disturbed him but on checking in the box that contained the new radio set, there were two resistors of 20 Ω and 8 Ω which he could not use either.

Hint: Resistors can be connected either in series or in parallel to lower the input voltage of the radio from 240 V to 100 V

Task

- (a) Help the farmer to connect the resistors to have his radio set work.
- (b) Explain to the farmer why you have decided to make the above connection.

Item 3

The mother developed a dental challenge but could not identify the exact tooth that should be extracted even after checking using her phone mirror. She decides to go the dental clinic. In the dental clinic, a small mirror was used and the tooth was easily identified. This made the mother to be more interested in the mirror and on checking, it had the following writings.

Radius of curvature = 20 cm

When she placed her face about 6.0 cm in front of the mirror, her face appeared different with bigger eyes and nose which left her wondering.

As a physics student,

- (a) Make use of a ray diagram to explain how the mirror in the clinic is different from the one at home and how it works.
- (b) Use a graph to support your explanation to the mother about the nature of the image of her face when she tried to look through it.

Item 4

Students of a certain school organised a tour to a water packing factory constructed on a mountain. On their way at the railway crossing, they stopped to allow the fast moving long train to cross. Many students moved out of the school bus to have a view of the train and to take selfies but they experienced a force pushing them towards the train which left them wondering whether the train has a magnetic effect that attracts human beings. At the water factory, they were told and even saw that the heated water moves through a vertical height against gravity to another storage tank without pumping it but the tour guide never explained to them the cause of this. On top of the hill where the factory is located, the barometer they had moved with read 740 mmHg.

Hint: At sea level, the mercury barometer reads 760 mmHg.

Density of mercury is 13600 kgm^{-3}

Density of air is 1.25 kgm^{-3} .

As a student of physics,

- (a) Help the students understand what happened at railway crossing.
- (b) Write a brief report explaining what makes it possible for the hot water to move against gravity.
- (c) Show the students how you would determine the height of the point on the hill where the factory is constructed above sea level.

Item 5

During a hospital tour, a liquid in a bottle spilled on one of the visitors. The visitor was told that the liquid that had spilled was a radioactive material of activity 450 counts per second with a half-life of two days. He was told to self-isolate in the hospital until the count rate drops to 6.25 counts per second. The relatives of the isolated person tasked the hospital administration to come up with better ways to keep such materials.

Support

Background radiation is 50 counts per second.

Use your knowledge of physics to

- (a) Determine how much time the patient would take in the hospital
- (b) Explain to the relatives the dangers associated with radioactive materials.
- (c) Explain to the hospital staff how such materials should be handled.

Item 6

Students in a certain school are going for a trip in a mountainous area where the maximum height one is allowed to climb is 1 km per day. They were allowed to have stop overs at specific points for various reasons. They had also been warned of the possibility of nose bleeding while climbing the mountain. Another group of students who had visited the same place earlier told them that their first stop over was at point B where the barometer read 68.2 cmHg while it read 75.7 cmHg at point A which was going to be the starting point. The students were told that cooking would be done at point A but they could not understand why this was so.

Use your knowledge of physics to help the students

- (a) Determine if they will be allowed to climb beyond point B.
- (b) Explain why the students were warned of the possibility of nose bleeding.
- (c) To explain why cooking had to be done at point A.

Item 7.

A young boy went to watch a football match on a cold evening. The boy observed that the goal keepers were wearing soft hand gloves, all the players were putting on shoes with spikes, the pitch surface was smooth. The balls used in this match can withstand a maximum impulsive force of 1000 N. One of the players kicked the ball, it hit the upright bar at a speed of 50 ms^{-1} and rebounded at a speed of 10 ms^{-1} . The time of contact between the ball and the bar was 0.1 seconds. The ball was immediately replaced and the boy wondered why this had been done. Players who were substituted were immediately dressed in heavy woolen black jackets with inner part silvered. The young boy was again surprised for this action. If the mass of the ball was 3.0 kg, Use your knowledge of physics to help the boy understand why

- (a) Gloves, playing shoes and the pitch surface are designed in such a way.
- (b) The ball was immediately replaced
- (c) The substitutes were given such specifically designed coats.

Item 8

A group of learners from a certain school visited a residence and were requested by a neighbor to press a switch by the door side. On pressing it, they heard a loud bell sound and the door was opened shortly. The learners were surprised when they were told it is an electric bell of 240 V,

40 W but could not explain how the bell works, what would happen if the bell was used on a house with a mains supply of 120 V and how the sound of the bell can be increased.

As a physics student,

- Explain how the device produces loud sound.
- Comment on what would happen if the electric bell was moved to a house with voltage of 120 V
- Suggest ways in which the sound from the device can be increased.

Item 9

An NGO is giving out radio and TV sets to people living in a valley surrounded by hills. The radio sets have a special antenna in form of a curved mirror. These people in this area listen to majorly three FM radio stations namely A-FM, B-FM and C-FM. These radio sets have a frequency bar as indicated below.

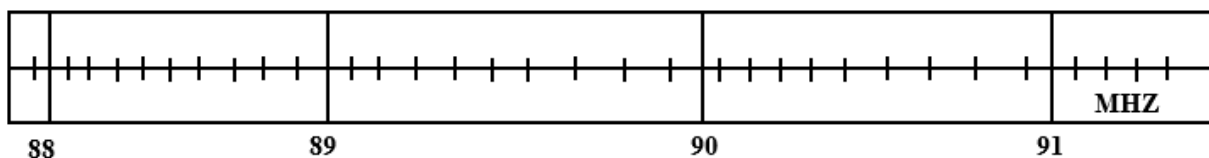

Both the radio and TV signals are weak in this area but TV signals are weaker compared to those of the radio set. The people find it difficult to manually locate the FM stations using the knob on the radio set. When you move very close to this curved mirror like antenna, a scaring image is formed in the mirror.

Hint

A-FM, B-FM and C-FM signals are broadcast at wavelengths of 3.40 m, 3.37 m and 3.33 m respectively and the speed of electromagnetic waves is $3 \times 10^8 \text{ms}^{-1}$.

As a learner

- Help these people to mark the 3 radio stations on the frequency bar shown in the figure above.
- Explain to these people why the TV signals are weaker than the radio signals.
- Comment on the nature and formation of the scaring images in the curved mirror.

(d) Suggest ways of improving on the strength of the radio and TV signals.

Item 10

A farmer uses one of his rooms for poultry. He uses a hot metallic charcoal stove to warm the room. Of recent, he is facing the following challenges

- (i) Some chicken lay eggs from a raised platform and the eggs at times accidentally slide and drop on the bare floor and break. This has greatly affected his poultry business.
- (ii) When bodies of the featherless bird touch the hot stove body, they get burnt.
- (iii) The odour from the birds' dung spreads throughout the other rooms on the house. This has become an inconvenience to the occupants in the house.

When the birds fight using their sharp beaks, they seriously damage each other. Inside the room, there is a wooden rod of weight 30 N supported by two identical strings. Usually cocks jump and rest on this rod. The two strings can only support a total tensional force of 90 N. At one moment, 3 cocks of average mass 3 kg each were resting on the rod and the ropes snapped. Use $g = 10 \text{ ms}^{-2}$

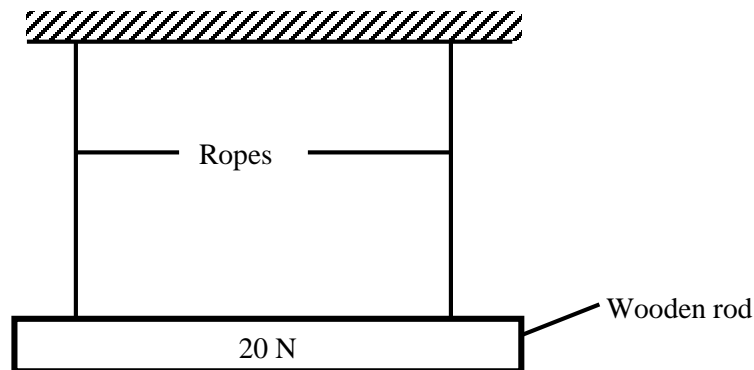

Using the knowledge of physics

- (a) Help the farmer understand the origin of his challenges and suggest the possible solutions to these challenges.
- (b) Help the farmer to find out why the ropes snapped.

Item 11

A certain family uses a special type of wax candle for multiple purposes including mosquito repellent, sources of light and heat and timer. This type of candle has uniform cross-sectional area of 3.0 cm^2 , length of 15.0 cm and a mass of 39.0 g . As it burns, wax melts at a rate of 2.0 cm per 30 minutes. It generates an odour which repels mosquitoes in all the rooms in the house. A student in this house is planning to use a similar candle of length 10.0 cm to revise at night from 8:00 pm to 11:00 pm. He is not sure whether this will be possible. The family also intends to place this type of candle on the water in a small water pool in order to chase the mosquitoes. (Use density of water as 1.0 gcm^{-3})

As a student of physics,

- (a) Help this family to understand how mosquitoes are chased away from all the rooms including the ceilings.
- (b) Advise the family on whether the candles will be able to float on water.
- (c) Help the student to find out whether the candle will burn for his planned time.
- (d) Suggest other traditional ways of measuring time.

Item 12

A patient who was suffering from liver cancer visited a hospital for treatment. He first checked in the radiographer's room. He was injected with Yttrium (Y-90) radioisotope dose of mass 6 mg into his bloodstream. The radiographer wrote a brief report.

Name: X

Date of visit: 2nd June, 2024

Next visit:

To report for next visit when dosage has reduced to 0.75 mg

Dr.A

He forgot to indicate the date of the next visit. The patient then went for X-ray photography. Unfortunately, he was told that the low voltage supply of the X-ray machine had mechanical issues and he was not worked on. The patient failed to understand the effect of that part of the machine on production of X-rays.

Using half-life of Y-90 as 5 days,
As a student of physics.

- (a) Help the patient to determine the date for his next visit.
- (b) Explain to the patient the effect of the faulty part of the X-ray machine on production of X-rays.
- (c) Sensitise the patient on the dangers of such dosages in treatment of the disease.

Item 13.

A boy was listening to a science program on BBC radio. The radio presenters opening remarks were;

- (i) Human beings are born and later die, so is the sun
- (ii) The death of the sun will automatically translate into death of the earth

Immediately the radio went off due to power black out

Using the knowledge of physics, help the boy to understand the two remarks.

Item 14

During an evening down pour, a sharp flash coupled with loud sound were witnessed. As a result, the whole village experienced a total blackout. Later it was discovered that a transformer had been damaged by the sharp flash. The village organised a meeting to solicit funds to purchase a new transformer. In attendance was the area Member of Parliament (MP) who promised the members that he was to purchase a device which can safeguard the transformer against other damages from such a flash. People wondered how the device can protect the transformer. After two weeks, the funds were realised and a committee was selected to go to town and buy the new transformer. The transformer dealer presented to the committee a transformer which supplies 12 V when connected to 240 V mains supply and it takes a current of 1.1 A from the mains when used to light ten 12V, 24W lamps in parallel. The dealer convinced the buyers that the transformer had an efficiency of at least 96%. They were not sure of how the dealer arrived at that value.

Using the knowledge of physics,

- (a) Find out whether the trader was trustworthy when he stated the above value.
- (b) Sensitise the community on how the device would guard the transformer against such destruction.

Item 15

An article in the newspaper gave information that on 2nd December 2022, Ugandan engineers with the help of Japanese engineers launched a satellite. The literature teacher who picked interest who picked interest in the article found new words like artificial and natural satellites. He developed a number of un answered questions which could be answered by a physics learner like you.

- (a) Explain the difference between the two types of satellites in the article.
- (b) With reasons, justify why Uganda should spend all that much money to launch its own satellite.
- (c) In case Uganda is to develop to a super rocket capable of reaching different planets. List with reasons the planets it can land on and planets it cannot land on.

PRACTICAL ITEMS

Item 1

A taxi that offers town service within Kampala City developed a mechanical fault of a leaking engine oil pressure and unnecessary noise. When taken to the garage for service, it was discovered that only 6-ball bearings of the crank shaft were in working condition and the rest were worn out. This prompted replacement of the worn out ball bearings with the correct sizes and refilling of the engine oil, which the mechanic's shop did not have. An attempt to buy the right size of the ball bearings hit a dead end when external diameters of working ball bearings were not known and there was no instrument within reach to determine the diameter of each ball bearing. James who is a friend to the driver has approach you with the ball bearings that are in working condition for guidance.

Task: Carryout a scientific investigation that can guide the driver to purchase the right size of the ball bearings for his taxi.

Hint:

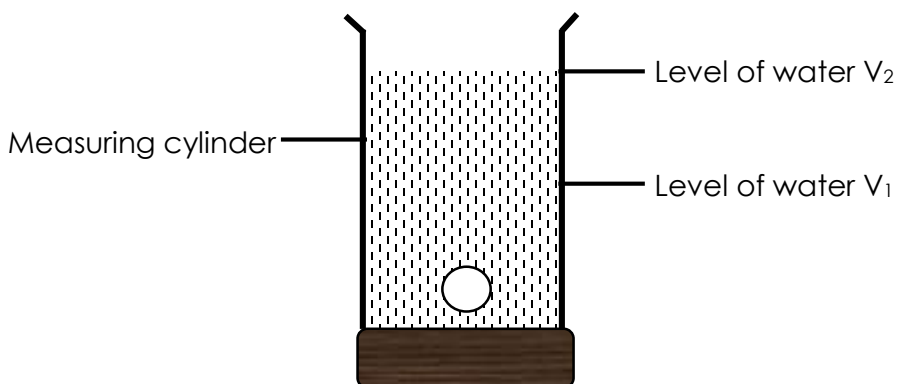

- Other experimental setups may be used
- $V = \frac{1}{6}\pi d^3$

Item 2

In your school, the physics club produces wooden metre rules as their project and sells them to Ministry of education and sports to be supplied to schools. The Ministry offers free transportation to her client only if the mass of the items exceed 20 tones. However, the club has a total of 35000 metre rules of the size and made from the same wood but have no idea of the mass of each metre rule, neither their total mass, and do not have any access to a weighing scale. One of the club executive members has approached you with a sample of these metre rules for help

Task: Carry out a scientific investigation to determine whether the club qualifies to get the offer of free transportation for their metre rules.

Hint:

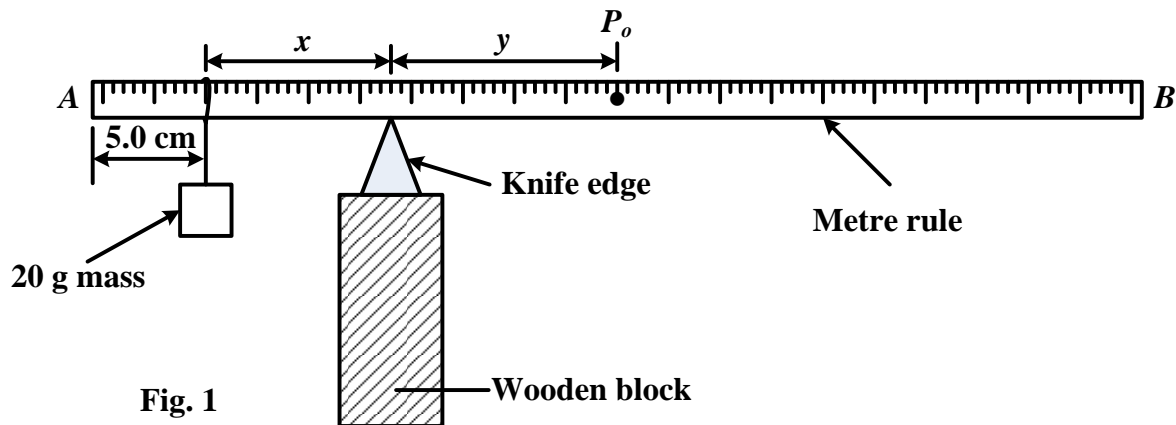

- Other experimental setups may be used
- $M_R = \frac{20x}{y}$.

Item 3

In one of secondary schools in the central region, the laboratory technician in-charge of the biology laboratory went to the village for burial, unfortunately this happened when senior one biology class were to use microscopes to study in depth features of a leaf. An effort to get the copy of keys from head of department hit a dead end since he was equally out station. This prompted the biology teacher to consult other departments where he was advised to improvise by using convex lens of magnifying power of 10 D. Physics laboratory has plenty of such lenses but are mixed with other lenses of different specification and are all not labeled.

Task: As a physics student, carry out a scientific investigation to sort the lenses such that lesson does not fail.

Hint.

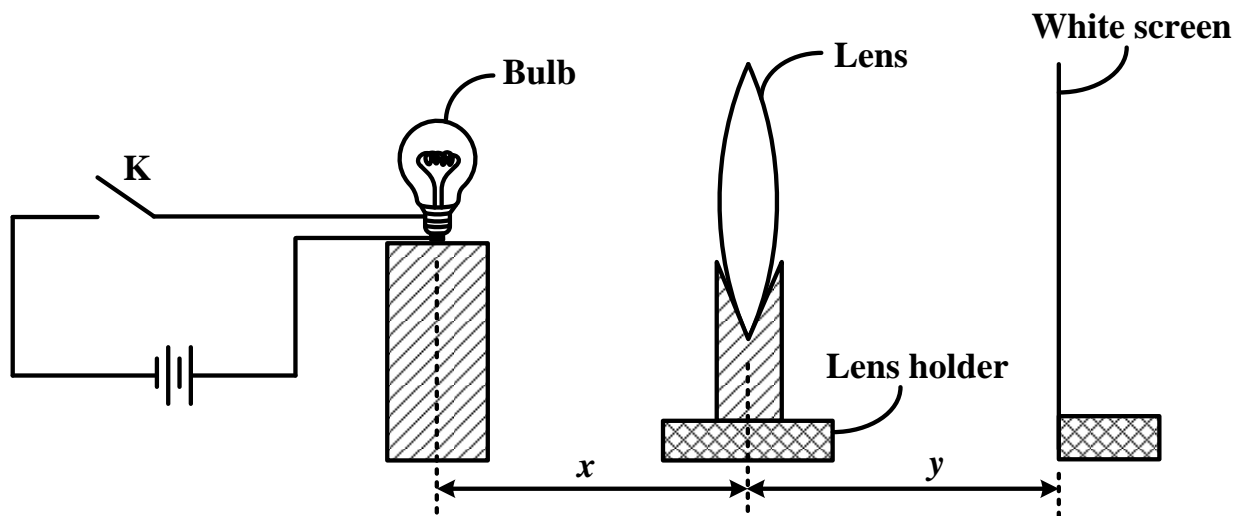

- Other experimental setups may be used
- $f = \frac{xy}{x+y}$ where x - is the object distance while y -is the image distance.

Item 4

A battery manufacturing company has received complaints of its products overheating, and having low life span. This made the company director to have a consultation with its team of experts' in-charge of quality assurance; they predicted that this could be as result of internal resistance of the batteries exceeding 1.8Ω and proved it right. In a bid to improve on the quality and life span of the batteries, the company's executive director decided that all the newly manufactured batteries should be tested before putting them into the

market. Unfortunately after the commencing the process of testing, the machine broke down. This forced them to seek for alternative approach which they are not familiar with, they seek for your expertise.

Task: Carryout scientific investigation to determine whether their newly manufactured batteries meet the minimum standards.

Hint: $E = V + Ir$ where E is e.m.f of the cells, V is p.d drop and I is current

