

AGRICULTURE

COMPLETE NOTES

FORM 1-4



  0725 103 013

 Teacher Daniel Online

 teacherdanielonline@gmail.com

FORM ONE

INTRODUCTION TO AGRICULTURE

The word Agriculture is derived from two Latin words **Ager** which means field and **cultura** that means cultivation. Therefore agriculture can be defined as **field cultivation**.

Livestock **are all the domesticated animals**.

Definition of agriculture:

Agriculture is defined as the art and science of crop and livestock production.

As an art

Involves use of learned skills and performing them manually (by hand). E.g.

- Tilling of land.
- Construction of farm structures.
- Measuring distances.
- Machine operations.
- Harvesting of crops.
- Feeding and handling animals.
- Marketing of Agricultural produce.

As a science

It involves experimentation and application of scientific knowledge e.g. in areas such as:

1. Soil science (pedology) ---study of soil.
2. Crop pathology—Study of crop diseases.
3. Entomology--- Study of insects and their control.
4. Agricultural Engineering--- soil and water conservation and farm power.
5. Genetics—Plant and animal breeding.

Production - Are activities that increase the quality and quantity of something.

Crop production activities include: land preparation, planting, fertilizer and manure application, weeding, pest control, disease control and harvesting.

Livestock production activities include:

- Selection and breeding.
- Feeding.
- Rearing the young stock.
- Parasite and disease control.
- Housing.
- Obtaining products from animals.

Branches of agriculture

1. Crop production: e.g. Field crop farming, pomology, Floriculture, olericulture.etc.
2. Livestock production: e.g. Apiculture, Poultry keeping, aquaculture.etc.
3. Soil science.
4. Agricultural Economics.
5. Agricultural Engineering.

Crop farming or Arable farming: Is the cultivation of crops on cultivated land. E.g. In pure stands (monocropping) or mixed stands (intercropping).

Include:

- i) **Field crops:** Are crops grown on large areas of land. Are either Annual crops like cereals and pulses or perennial crops e.g. coffee, tea, sisal, cane etc.
- ii) **Horticultural crops:** Are perishable crops and are exported to earn foreign exchange. Include:

- a) Floriculture:** Growing of flowers e.g. tuber rose, roses, and carnations.
- b) Olericulture:** Growing of vegetables e.g. French beans, cabbages, tomatoes.etc..
- c) Pomology:** Growing of fruits e.g. avocado, mangoes and citrus.

Livestock farming: Include:

- i) Pastoralism (mammalian livestock farming). Is the** rearing of farm animals on pastures. E.g. cattle, goats, pigs, sheep, camels and rabbits.
- ii) Fish farming (Aquaculture); Is** the rearing of fish in fish ponds. Fish is a cheap source of proteins.
- iii) Bee keeping: (Apiculture); Is** the rearing of bees in bee hives. Bees provide ; Honey and Wax, income, Medicine, pollination of flowers.etc.
- iv) Poultry keeping;** Is the rearing of birds for meat and eggs, manure, income. Etc. Include classes of birds such as chicken (most common), Ducks, geese, Ostrich, pigeon and Turkeys etc.

Agricultural Economics: Deals with utilization of scarce resources i.e. of land, labour, capital and management. It aims at maximizing output while minimizing costs.

Agricultural Engineering; Deals with use and maintenance of farm tools and equipment, farm machinery and farm structures.

FARMING SYSTEMS

A farming system is an organization of the farm and all the enterprises in relation to each other.

It can be extensive or intensive.

Extensive system

Characteristics

1. Large tracts of land.
2. Low capital investment per unit area.
3. Low labour per unit area.
4. Low yields per unit area.

Intensive system

Characteristics

1. Small tracts of land.
2. High capital per unit area.
3. High labour investment per unit area.
4. High yields per unit area.

Extensive or intensive farming can be carried out on small or large scale of land.

The scale of production depends on:

- Level of technology.
- Land availability.
- Capital availability.
- Skilled labour available.

i) Large Scale Farming

Characteristics

- Large tracts of land.
- Heavy capital investment.
- Skilled labour and qualified man power.
- High level of management.
- It's for commercial purpose.
- Low operation costs per unit of production since it makes use of economies of scale.
- Depends on efficient transport.

- Requires good market system.
- Most of the work is mechanized.
- Provides more employment.

It includes plantation farming and Ranching.

a) Plantation farming.

Characteristics

- Large tracts of land.
- Production of only one crop.e.g. Tea plantations in Kiambu and Kericho, Coffee in Kiambu, Sugarcane in Muhoroni, Sisal in Mombasa, Pineapple in Thika.

b) Ranching : Is the keeping of livestock (beef animals) in marginal range areas.

It is an improved pastoral-nomadism because:

- Animals are enclosed in an area.
- Diseases are controlled.
- Pastures are improved.
- Supplementary feeds and water are provided.
- Pests and parasites are controlled.
- There is provision of extension staff.

N.B The livestock carrying capacity is low because of limited pasture.

Ranching is becoming more and more common in Kenya because of:

- High meat demand.
- High population pressure on high potential areas.
- Arable farming is becoming smaller.

ii) Small Scale Farming

Characteristics

- Small piece of land.

- Use of improved technology.
- Production of crops and livestock is spread throughout the year.
- Goods are produced for subsistence or commercial purpose I,e sale of surplus goods..
- Does not require heavy capital investment.

Advantages

- Little capital is required.
- Source of livelihood to small scale farmers.

Methods of Farming

i) **Mixed Farming**

- **This is the growing of crops and rearing of animals on the same farm.**

Advantages

- It is a method of diversification whereby should one enterprise fail, the farmer can benefit from the other.
- There is mutual benefit between the crops and livestock where crops provide feed for livestock and animals provide them with farm yard manure.
- There is maximum utilization of resources.

Disadvantages

- Labour intensive.
- High initial capital required.
- Farmer's attention is divided.

ii) **Nomadic Pastoralism**

Pastoralism: This is the practice of rearing livestock on natural pastures.

Nomadism: This is the practice of moving from one place to another.

- Pastoral –nomadism is therefore the moving of animals from one place to another in search of pasture and water.
- This is common in the arid and semi-arid areas.

iii) **Shifting Cultivation**

- Farming on a piece of land continuously until it is exhausted after which the farmer moves to a new more fertile land.
- It is applicable where;
 - ✓ Land is abundant
 - ✓ Population is sparse
 - ✓ Number of livestock per unit area is low.
 - ✓ Land is communally owned.

Advantages of shifting cultivation

- i) It has low capital requirement
- ii) There is no pests and diseases build-up
- iii) Soil structure is maintained
- iv) No land disputes as land ownership is not individualized.

Disadvantages of shifting cultivation

- i) Total yields per unit are is low
- ii) Farmers have no incentive to develop land and conserve water and soil
- iii) A lot of time is wasted when the farmer is shifting and building structures.
- iv) Not applicable in areas of high population density or where there is high population increase.

iv) Agroforestry

Agroforestry - Involves growing of trees and crops and keeping of animals on the same piece of land at the same time.

Suitable tree species for agroforestry

- *Leucaena leucocephala*
- *Gravillea robusta*
- *Calliandra catothrysus*

- Mangifera indica
- Sesbania sesban
- Lantana camara
- Cajanus cajan

Advantages of Agroforestry

- i) Saves labour since some operations can be done at once for both plants and trees
- ii) Gives higher combined yield
- iii) Provide wide variety of agricultural produce
- iv) Reduces the risks of total failure
- v) Crops benefit from nitrogen fixing trees.
- vi) Trees help in holding the soil firmly
- vii) Some trees act as livestock fodder.
- viii) Provides a wider variety of agricultural produce.

Disadvantages of Agroforestry

- i) Mechanization is difficult.
- ii) Use of pesticides and fertilizer may be difficult.
- iii) Productivity may suffer because the skills for managing the different trees

FACTORS INFLUENCING AGRICULTURE

1. HUMAN FACTORS.

They are factors in human beings or the way human beings do things.

The following is a list of human factors that influence agricultural production.

a) Levels of education and technology

- This is translated as the ability of a producer who is a farmer to apply appropriate methods and techniques in

production using available resources for example, Farmer weighing livestock food to ensure efficiency

- Good education level makes a farmer able to understand and translate technical language in farming.

b) Health of the farmers

- **A healthy nation is a productive nation**

- The following are some of the diseases that contribute to lowering agricultural productivity
 - ✓ Malaria,
 - ✓ Tuberculosis,
 - ✓ Typhoid,
 - ✓ Pneumonia and HIV/AIDS

Effects of HIV/AIDS on farming

- ✓ Loss of skilled labour
- ✓ Time spent caring for the infected
- ✓ Money spent on treatment

c) State of economic development

- The capital earned from economic activities such as farming is used to raise economic growth in the country.

d) Transport and communication network

- Good and efficient infrastructure is important for the smooth flow of farm produce from the farm to the consumer.
- The improvement of technology in communication has improved farmers access to important information from the research stations and other fellow farmers

e) Government policy on agricultural input and produce taxation

- The government of Kenya, through different ministries formulates guidelines to be followed by producers of different products. After the guidelines and proposals are legislated they become policies

f) Availability of storage facilities

g) Cultural and religious beliefs.

h) Local and International market forces

Human Factors which improve production

- Good health of the farmer
- Availability of money
- High taxation on imported agricultural produce
- Availability of ready market for agricultural produce
- Availability of storage facilities
- Liberalized market

Human Factors which lower production

- Restrictive cultural and religious beliefs
- Poor road network

2. BIOTIC FACTORS.

- These are living organisms that affect agricultural production.
- Biotic factors influencing agriculture can be divided into the following classes.
 - ✓ **Crop pests:** stalk borer damaging maize in the field
 - ✓ **Decomposers:** Cause rotting of organic matter there by releasing nutrients for crop growth. They help in improving soil structure through incorporating organic matter into the soil.
 - ✓ **Nitrogen fixing Bacteria:** Nitrogen fixing bacteria are found in root nodules of leguminous plants. Improve

crop production through increasing soil nitrogen content which crops require for proper growth.

- ✓ **Livestock parasites:** suck blood and transmit diseases to animals
- ✓ **Pollinators:** Bee pollinating maize flower. Pollination in crop production increases yields and viability of seeds.
- ✓ **Predators:** Eagles can eat chicken, rabbits among other livestock. Eagle can also eat insects and pests for example rats, moles and birds which destroy crops.
- ✓ **Pathogens:** Causes diseases in livestock and crops thereby lowering quality of produce. Increase cost of production when control measures are implemented. Introduce toxic substances into agricultural products thereby lowering the quality of the produce. Can cause death to crops and animals.

Effects of Biotic Factors on Agricultural Production

1. Pests

- Feed on crops thereby lowering quantity of agricultural produce.
- Feed on grains thereby affecting viability of the seeds
- Act as disease vectors
- Lower palatability of crop produce
- Increase cost of production when control methods are applied
- Create entry points for disease causing organisms

2. Parasites

- Irritate livestock
- Causes anemia in livestock
- Some block alimentary canal
- Lower rate of production in livestock
- Increase cost of production when controlled
- Some lower quality of hides and skins
- Some absorb food meant for the livestock thereby lowering the level of production.
- Some for example ticks transmit disease causing organisms.

3. CLIMATIC FACTORS.

Climatic factors include:

- **Rainfall**

- ✓ Poor rainfall distribution results to wilting of crops
- ✓ Excess rainfall can cause soil erosion
- ✓ Excess rainfall can result to crop failure due to flooding.

The four aspects of rainfall which affect agricultural production include:-

a) Rainfall Amount

Rainfall amount refers to quantity of rainfall received in a given area for a period of one year. Rainfall amount is measured using a rain gauge in millimeters per annum. The amount of rainfall determines the crops grown in an area.

b) Rainfall distribution

This refers to the spread of rainfall over the year. Rainfall distribution is very poor in Kenya and therefore irrigation is necessary to supplement the short supply.

c) Rainfall reliability

This refers to the certainty with which a given amount of rain is expected in a given place in the year.

d) Rainfall Intensity

This refers to the strength with which rain falls; it is therefore measured in terms of amount per hour.

Rainfall of low intensity is preferred as it improves water infiltration into the soil and causes less soil erosion.

• Temperature

- ✓ Temperature is the coldness or hotness of a place.
- ✓ Temperature is measured in degrees Celsius using a thermometer.
- ✓ Temperature is influenced by altitude and topography.
- ✓ Temperature decreases with increase in altitude, such that for every 300 meters rise in altitude above sea level temperature decreases by 1.7-2.2 degrees Celsius.
- ✓ Each crop has a temperature range within which it can grow referred to as the cardinal range of temperature.
- ✓ For crops to grow well and produce high yields, they require a narrow temperature range within the cardinal range referred to as optimum range of temperature

Effects of temperature on agriculture

Low temperature

- ✓ Slow growth rate.
- ✓ High incidences of disease such as CDB in coffee.
- ✓ Improvement of quality in crops such as tea and pyrethrum.

High temperature

- ✓ High evaporation rate hence wilting in crops.
- ✓ Hasten the rate of maturity due to increased growth rate.

- ✓ Improvement of quality in crops such as pineapples and oranges.
- ✓ Increase incidences of diseases such as leaf rust in coffee.
- ✓ Increased incidences of pest infestation such as aphids in vegetables.

Effects of altitude on agriculture

- ✓ Kenya is divided into three ecological zones which include;
- ✓ Low altitude zone 0 - 1500 meters above sea level
- ✓ Medium altitude zone 1500 - 2500 meters above sea level
- ✓ High altitude zone above 2500 meters above sea level

Crops perform differently when grown in each of these ecological zones and therefore each crop has its most suitable zone for maximum performance as illustrated below.

- **Wind**

Wind refers to air in motion.

- ✓ Below is a list of effects of strong wind on agricultural production.
 - a) Blowing and bringing rain bearing clouds
 - b) Destruction of farm structures
 - c) Strong wind may cause lodging in weak plants.
 - d) Wind erosion on bare land
 - e) Increases rate of moisture evaporation
 - f) Increase spread of pests and diseases
 - g) Agent of dispersal.
 - h) Pollination in crops.

- **Light**

- ✓ Light is the source of energy which plants require for photosynthesis.

- ✓ During photosynthesis, plants manufacture food using water and carbon dioxide in the presence of sunlight and chlorophyll.

Aspects of light that influence agriculture

i). Light intensity.

- ✓ This is the strength with which light hits the surface of the earth.

ii) Light duration

- ✓ This is the period of time the plants are exposed to light recorded using a Campbell sunshine recorder

Photoperiodism

- ✓ This is the response of plants toward light duration.

Long day plants

- ✓ These are plants which require more than 12 hours of lighting to flower and produce fruits or seeds e.g. some wheat varieties

Short day plants

- ✓ These are plants which require less than 12 hours of lighting to flower and produce e.g Maize

Day neutral plants

- ✓ These are plants which produce flowers regardless of the duration of lighting they have been exposed to e.g Tobacco.

iii) Light wavelength:

- ✓ This refers to the type or quality of light. A wavelength is the distance between two corresponding points of a light wave.
- ✓ Chlorophyll absorbs certain wavelengths of light which are not present in artificial light unless it is ultra violet or infra red.

NB/ Green houses can be used to control the temperature, relative humidity and light duration and intensity.

- **Relative Humidity.**

- ✓ This is the amount of water vapour held by air at a given temperature.
- ✓ At high humidity the rate of evaporation is low and vice versa.

4. EDAPHIC/SOIL FACTORS

- Soil is a mixture of weathered rock and decayed organic matter.
- It supports plant growth by providing anchorage nutrients and water.
- Topsoil covers most of the earth and it contains minerals, organic matter, air, water and living organisms.

Soil Formation

- Soil is formed through the process of weathering.
- Weathering is the breakdown and alteration of the parent rock near the earth's surface.
- Parent rock is first broken into smaller fragments and eventually into individual constituent minerals.
- The individual minerals combine to form the soil.
- Weathering is a continuous process and it takes hundreds of years to form a centimeter of the soil.
- Weathering involves breakdown (disintegration) and building up (synthesis).
- Weathering process is influenced by the following factors.
 1. Climate.
 2. Parent material.
 3. Topography.

4. Living organisms.

5. Time.

Agents of The Weathering Process.

i. Physical agents.

- In this case no chemical changes are involved.
- These include wind, water, moving ice and temperature.
- Strong winds carry materials which hit against each other and break into smaller fragments.
- Raindrops hit the ground with some force causing soil erosion.
- Moving ice causes rocks to disintegrate.
- High temperatures in the arid areas cause the rocks to at different rates. During the night, temperatures drop making the rock to contract. The rock surface contracts faster than the inside. This unequal contraction causes the rocks to disintegrate.
- In places with very low temperature, water gets into the cracks, freezes and becomes ice. As water turns into ice, it increases in volume pushing the rock apart hence disintegration.

ii. Biological agents.

- This involves living organisms.
- Large animals like elephants and cattle exert pressure on rocks as they move causing them to break.
- Mans activities such as mining, quarrying, road construction and earth moving breaks rocks into smaller fragments.

- Bacteria and fungi help in the breakdown of plant and animal tissues (decomposition). These materials are incorporated into the soil.
- Termites and moles bring to the surface large quantities of fine materials. This promotes weathering by aerating lower layers of the rocks.
- Roots of plants force their way through rocks making them to disintegrate. They also produce acids during respiration which dissolves rock minerals. Decayed roots may mix with water forming organic acids which dissolves rock minerals.

iii. Chemical agents.

- This is the decay or decomposition of the rocks. It involves the following processes.

a) Carbonation.

- As the rain falls through the atmosphere, it dissolves some CO_2 forming weak carbonic acid.
- Over time this acid reacts with the rock minerals particularly calcium carbonate causing decomposition.

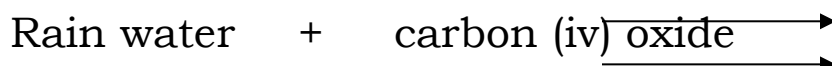

Carbonic acid.



Calcium bicarbonate

- The calcium bicarbonate formed in this reaction is soluble in water causing water to eventually dissolve the entire rock.

b) Oxidation.

- Oxygen reacts with many elements found in rocks causing them to disintegrate.

- c) *Solution.*
- d) *Hydrolysis.*
- e) *Hydration.*

Factors Influencing Soil Formation

I. Parent rock material

- This influences the physical and chemical properties of the soil such as
 - a) The texture of the soil e.g. granite gives coarse grained soil.
 - b) Mineral composition of the soil e.g. rocks containing calcite, feldspar and ferro-magnesium minerals produce deep heavy soils rich in nutrients.
 - c) The rate of soil formation e.g. limestone is easily weathered in warm humid regions and the carbonates are easily soluble.
- Since the parent material influences the physical and chemical properties of the soil, it therefore controls the type of vegetation in an area.

II. Climate

- High temperature speed up the rate of chemical reactions.
- Wind acts as a transport agent and carries the weathered materials from one place to another. Where a lot of weathered materials are deposited, the soils are deep and rich in nutrients.
- Rainfall provides water which is an important reagent during the weathering process. A lot of rain may cause rocks to break hastening the weathering process.

III. Topography(Relief)

- This is the shape of the land in relation to the underlying rock of the earth's surface.
- It may quicken or slow the weathering process.
- The slope affects the depth of the soil and kind of vegetation growing in an area.
- Soils found in flat land and low lying areas tend to be more fertile than those found on higher slopes. Such areas have deeper soils.
- On a steep slope, erosion is high and such areas have shallow soils.

IV. Living organisms(Biotic factors)

- The presence of the various agents of biological weathering speeds up the process of soil formation.

V. Time.

- The process of soil formation is very slow and takes a lot of time.
- Deep mature soils are found where soil forming processes have taken place over a long period.
- If the parent material is resistant to weathering agents, more time is required for the soil to mature.
- Areas with severe soil erosion have a poorly differentiated soil profile.

SOIL PROFILE

- This is the vertical arrangement of the soil horizons (layers).
- The horizons show soil layers at different stages of development.

- Soil forming processes are continuous and the soil develops in depth resulting in the formation of the distinct sequence of soil layers.
- The layers differ from each other in terms of colour, organic matter content, chemical composition, porosity, depth and the arrangement of soil particles.

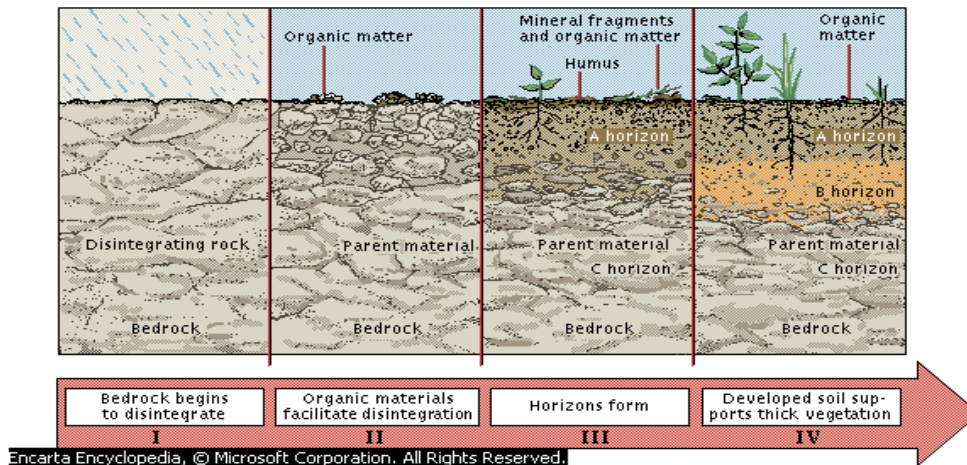

The horizons are;

a) Superficial layer.

- It's a thin layer consisting of dead decaying and decayed organic matter covering the soil.

b) Top soil (Horizon A).

- It lies beneath the superficial layer.
- It contains a lot of humus hence it's darker than the other layers.
- It's well aerated and contains active living organisms.
- It's well drained and rich in plant nutrients.
- Most of the roots are found here.

c) Sub soil (Horizon B).

- Found beneath the top soil.
- More compacted and less aerated than top soil.

- May contain an impermeable layer called the **hard pan** which may prevent drainage and root penetration.
- Minerals leached from top soil accumulate here hence this layer is referred to as **the layer of accumulation**.
- It has clay deposits.

d) Substratum/weathered rock (Horizon C).

- Made up of partly weathered rocks.
- Has no humus.
- Hard and impermeable to water.
- Roots of big trees may reach this layer and draw water from it during the dry season.

e) Parent rock/Bed rock (Horizon D).

- It's found beneath the weathered rock. Soil is formed from this rock. It may contain ponds of water.

NB/ . Between any two bordering soil layers, there is a transitional zone whereby one layer gradually merges into the next one in the series.

The soil profile influences agriculture in the following ways.

- a) Topsoil contains most of the soil nutrients, well aerated and has soil microorganisms.
- b) A well developed profile holds more moisture for plant use than a shallow one.
- c) Loosely packed subsoil allows easy root penetration, drainage and aeration.
- d) Nature and composition of the bedrock determines the mineral components of the whole soil.

SOIL CONSTITUENTS

i. Mineral matter.

- The mineral composition of the parent rock determines the mineral constituents of the soil.
- The mineral matter makes the framework of the soil.
- It holds the roots firmly in the soil giving anchorage to plants.
- Between the particles are spaces which are filled with water and air.

Diagram

ii. Organic matter.

- When the dead materials rot, they are decomposed by bacteria and fungi to form the soil organic matter.
- Humus is dead organic matter which is in the state of continuous chemical decomposition, transformation and construction.
- Humus in the soil improves the soil structure.
- Humus contains plant nutrients such as sulphates, nitrates, phosphates, calcium, magnesium, potassium etc.

iii. Air.

- The soil contains all the gases such as nitrogen, oxygen, CO_2 and the rare gases.
- Availability of air in the soil is influenced by the type of the soil and amount of water in the soil.
- Oxygen is needed by plants during respiration. It is also required by microorganisms in the soil during decomposition and nitrogen fixation.
- Excess CO_2 in the soil is poisonous to plants and microorganisms.
- For best crop performance, a balance of soil water and soil air has to be maintained.

iv. Water.

- Soil contains water. Soil water exists in three forms;
a) Superfluous water.
- This is water occupying large air spaces (macro pores).
- This water is loosely held by the soil and therefore easily lost.
- The water is readily available to plants but not useful because excess water in the soil brings about poor aeration.
- A lot of water in the soil causes leaching of nutrients.
b) Capillary water.
- This is water occupying small pores (microspores).
- It is held with greater force by soil particles.
- It is available to plants and acts as a solvent for plant nutrients.
- It is also referred to as available water.
- It leaves most of the macro pores empty allowing aeration of the soil.
c) Hygroscopic water.
- This is water that forms a thin film around the soil particles.
- It is firmly held by soil particles making it not available to plants.
- Clay particles have a lot of hygroscopic water but sandy soils contain very little hygroscopic water because sandy particles have weaker forces.

Importance of water to plants

- 1) A solvent for plant nutrients.
- 2) Raw materials for photosynthesis.

3) During transpiration plants lose a lot of water hence a cooling effect on them.

4) Water makes plant cells turgid hence support.

v. Living organisms (biotic factors)

- They are important in the soil in the process of decomposition.
- They are divided into ;
 - i. **Soil microorganisms**
- They include bacteria, fungi and protozoa. They help in decomposition process.
- Some bacteria e.g. Rhizobium spp helps in nitrogen fixation in legumes.
- Some microorganisms are harmful because they cause diseases.
 - ii. **Soil macro organisms**
- They are larger organisms found in the soil such as moles, earthworms, termites, ants and plant roots.
- They burrow in the soil aerating the soil and making it loose..

PHYSICAL PROPERTIES OF THE SOIL

i. Soil structure

- This refers to the physical appearance of soil according to how the individual soil particles are arranged, packed or aggregated.
- The **soil structure type** is determined by the general shape of the aggregates.
- **Soil structure class** is determined by the size of the aggregates.

- The **soil structure grade** is determined by the stability or cohesiveness of the aggregates.

Types of soil structures

i. Single grained structure.

- There is no aggregation at all.
- Particles are not cemented together. The particles are non-porous and spherical.
- Mostly found in the top soil of sandy soils, arid climates and alkaline soils.

ii. Crumbly soil structure.

- The aggregates are small, soft and porous irregular in shape.
- Aggregates are not closely fitted together.

iii. Granular soil structure.

- The aggregates have irregular shape called granules.
- Soil is very porous when wet.
- Structure is found in the topsoil of cultivated soils and in the subsoil of soils under grass or bush.

iv. Prismatic soil structure.

- Aggregate are arranged vertically.
- The vertical axis of each aggregate is longer than the horizontal axis.
- When the tops are rounded, they are said to be columnar and when they have flat ends they are prismatic.

v. Platy soil structure.

- The aggregates are arranged on top of one another in thin horizontal plates.

- The structure has poor permeability, drainage and root penetration.
- Structure is mostly found in top horizon of soils in the forest and in clay soils.

vi. Blocky soil structure.

- Aggregates are arranged in rectangular blocks.
- Aggregates easily fit together along vertical edges.

Importance of Soil Structure on Crop Production

Soil structure influences:

- a) Soil aeration.
- b) Soil drainage and water holding capacity.
- c) Plants root penetrability and anchorage.
- d) Microbial activities in the soil.
- e) Circulation of gases in the soil.

The following farming practices improve the soil structure

- a) Application of inorganic manure into the soil.
- b) Tilling the land at the right moisture content.
- c) Crop rotation.
- d) Minimum tillage.
- e) Cover cropping.
- f) Mulching.

Soil texture

- It refers to the relative proportion of the various sizes of the mineral particles of soil.
- Also defined as the coarseness or fineness of the soil when felt between the fingers.
- Different soil particles have different sizes as shown below.

Particle	Size (Diameter) in mm
Stones (Gravel)	Above 2.00 mm
Coarse sand	Between 0.20 – 2.00 mm
Fine sand	Between 0.02 – 0.20 mm
Silt	Between 0.002 – 0.02mm
Clay	Below 0.002 mm

Determination of Soil Texture

This can be done through;

1. Mechanical analysis.
2. Chemical analysis.

Mechanical analysis

Apparatus

Garden soil, sieves of different measured mesh diameter, containers and weighing balance.

Procedure

1. Put a known amount of soil sample into a container.
2. Crush the soil lumps without breaking the particles.
3. Pass the soil through the sieve with the largest mesh diameter (2.00 mm) and shake vigorously.
4. Weigh the soil that remains on the sieve and record.
5. Repeat the process using other sieves with mesh diameters of 0.2mm, 0.02mm and 0.002mm always using the soil that passes through the previous sieve.

Observation

- Soil particles left on first sieve of mesh diameter 2.00mm are called gravel.
- From the second sieve of 0.20mm; coarse sand particles.

- From the third sieve (0.02 mm); fine sand particles.
- From the fourth sieve (0.002 mm); silt particles.
- All the particles that pass through the fourth sieve are clay particles.

Importance of soil texture on crop production

1. Influences soil fertility.
2. Affects the organic matter content.
3. Influences the drainage of the soil.
4. Influences soil aeration.
5. Influences water holding capacity
6. Influences the capillarity or movement of water in the soil.

NB/ Based on texture, soil can be classified as;

1. **Sandy soil. (50-80% sand, 20-50% silt and clay and 0.1-3% organic matter).**
 - Are made up of largely sand particles (coarse textured).
 - Have large air spaces hence poor in water retention.
 - Easy to till (light soils)
 - Low fertility due to leaching of minerals.
 - Easily eroded.
 - Free draining.
 - These soils can be improved by addition of organic matter and fertilizers.
2. **Silty loam (20-30% sand, 70-80% silt and clay and 0.1-4% organic matter).**
 - Fine textured
 - Well drained
 - Good water holding capacity.
 - Moderately fertile and aerated.

- Area acidic to moderate pH.
3. **Clayey loam soils. (20-50% sand, 20-60% silt and clay and 0.1 - 6% organic matter).**
- Poorly drained and aerated
 - Fine textured
 - High capillarity and water holding capacity.
 - Slightly acidic to slightly alkaline.
 - Rich in plant nutrients.
 - Difficult to work on when dry or wet.
 - Are suitable for flood irrigation of crops like rice.
4. **Clayey soils. (> 40% clay content)**
- Made up of largely clay particles.
 - Have small pore spaces hence good in moisture retention.
 - Difficult to till (heavy soils)
 - Poorly drained.
 - Expand when wet, crack when dry.
 - High capillarity.
 - Rich in plant nutrients.
 - Are suitable for flood irrigation.
 - They can be improved by drainage.
5. **Loamy soils. (30-50% sand, 50-70% silt and clay and 0.1 - 4% organic matter).**
- Moderately textured and drained.
 - Slightly acidic.
 - Do not erode easily.
 - Easy to work on.
 - Have a good water holding capacity.

- They are the most suitable for crop production since they contain good amounts of plant nutrients and organic matter.
- They can be improved further by planting cover crops to maintain fertility and by adding manures and fertilizers.

Soil Colour

- This depends on the mineral composition of the rock and the organic matter content.
- Soils containing a lot of iron are brownish, yellowish or reddish in colour.
- Soils with a lot of silica are white.
- Soils with a lot of humus are dark or grey.
- Soil colour influences the soil temperature.
- Dark soils absorb and retain more heat than light coloured soils.
- Relatively high temperatures in the soil enhance microbial activity.

Soil pH

- This refers to the acidity or alkalinity of the soil solution.
- It is determined by the concentration of hydrogen ions (H^+) or the hydroxyl ions (H^-) in the soils solution.
- pH is measured using the pH scale which ranges from 1-14.
- A pH of less than 7 means that the soil solution is acidic.
- A pH of more than 7 means that the soil is alkaline.
- pH of 7 is neutral.

- As the hydroxyl ions in the soil increase, the soil becomes more alkaline and vice versa.

Influence of Soil pH on Crop Growth

- Determines the type of crop to grown in a particular area.
- Affects the type of fertilizer to be used.
- Affects the availability of some nutrients e.g. at low pH phosphorous and molybdenum are less available while high pH makes manganese, potassium, iron, boron and zinc less available.
- Very acidic or very alkaline conditions affect activities of soil microorganisms.

Modifying Soil pH

The following are applied to the soil in order to lower its pH (Increase soil acidity)

- Application of sulphur.
- Application of acidic fertilizers such as sulphate of ammonia.

In raising its pH (increase alkalinity) the following is done.

- Application of lime which is a basic compound which raises the soil pH after some time.
- Application of basic fertilizers.

Agricultural Economics

- Agricultural economics is defined as an applied science that aims at maximizing output while minimizing costs, by combining the limited resources of land, capital, labour and management to produce goods and services for use by the society over a period of time.

Basic Economic Concepts

a) Scarcity.

- The factors of production such as land, capital, labour and management are scarce or limited.
- The farmer therefore must decide on how to allocate the few/scarce resources to the many competing production needs.

b) Preference and Choice

- Since the available resources are limited and production needs are many, a farmer has to make a choice of how to allocate these resources.
- A farmer therefore has to choose one or several enterprises from very many.
- The choice made is determined by factors such as needs of the society, farmer's preference and ecological conditions.

c) Opportunity Cost

- Since a choice has to be made from very many competing enterprises, some revenue has to be foregone. For example, a piece of land may be suitable for the production of maize and wheat.
- If a farmer chooses to grow maize, the returns that the farmer would have obtained from wheat is foregone.
- The foregone returns are called the opportunity cost. Opportunity cost is the revenue foregone from the best alternative.

Farm Records

- These are documents kept in the farm showing farm activities over a period of time.
- They should be neat, concise and complete showing actual amounts, weights, measurements or dates.

Uses of farm records to a farmer

- i. Help to determine the value of the farm/ determine assets and liabilities.
- ii. Provide history of the farm.
- iii. Assist in planning and budgeting in various fields.
- iv. Helps to detect losses or theft in the farm.
- v. Assists when sharing losses or profits (dividends) for communal owned farms/ partnership.
- vi. Help to settle disputes in the farm among heirs.
- vii. Help to support insurance claim e.g. against fire and theft.
- viii. Provide labour information like terminal benefits, NSSF due, Sacco dues for all employees.
- ix. Help to compare the performance of different enterprises within a farm or other farms.
- x. Help in the assessment of income tax to avoid over or under taxation.
- xi. Records help to show whether the farm business is making profit or losses. This information helps in obtaining credit.

Types of Farm Records

a) Production Records

- They show the total yield and the yield per unit of each enterprise such as the total number of litres of milk from the whole herd and from each cow.

Name /No. of cow	Days in the month						TOTA LS et c
	1	2	3	et			
	A	P.	A.	P	A	P	
	M	M	M	M	M	M	
1							
2							
3							

4
etc
Totals

b) Inventory records

- They show all the assets on the farm e.g. livestock, machinery, buildings, crops etc.
- They are divided into two;
 - **Consumable goods** such as animal feeds, fertilizers, fuel, pesticides etc.
 - **Permanent goods** such as machinery, farm tools and equipment, buildings etc.

Consumable Goods Inventory

			Receipts		Issues		
Dat	Commodity/I	Quanti	Dat	Issu	Quanti	Balan	
e	tem	ty	e	ed	ty	ce in	
				to		Stock	

Permanent goods Inventory

Dat	Commodity/It	Quanti	Writte	Balan	Comme
e	em	ty	n off	ce in	nt
				Stock	

c) Field Operations Records

- They show all the activities being carried in the field such as date of ploughing, planting, fertilizer used etc.
- They help to work out the cost of production for each field at the end of the season.

d) Breeding Records

- They are kept to show the breeding activities and programmes for various animals on the farm.
- There are different breeding records depending on the animals being reared.

e) Feeding Records

- They show the type and amounts of feeds used to feed the animals.

Daily feeding record for the month

of.....

Enterprise

.....

.....

Type of

feed.....

.....

Date	No. of Animals	Amount Received (kg)	Amount Used (Kg)	Balance in Stock (Kg)	Remarks
-------------	-----------------------	-----------------------------	-------------------------	------------------------------	----------------

f) Health Records

- They show the health conditions of the animals. They show when actions such as vaccinations and deworming are to be done.
- They help in the selection of the breeding stock. They also help in calculating the cost of treatment.

Date	Disease symptoms	Animal(s) affected	Drugs used	Cost of treatment	Remarks
-------------	-------------------------	---------------------------	-------------------	--------------------------	----------------

g) Marketing Records

- They show the commodity, quantity, amount sold, date, rate per unit of the commodity, total value and where sold.

Commodity.....

Date	Amount sold	Price per unit (kshs)	Total Value (ksh)	Where sold	Remarks
-------------	--------------------	------------------------------	--------------------------	-------------------	----------------

h) Labour Records

- They show the type of labour, date of employment, rate of payment, skilled and unskilled labour.
- They are divided into two;
 - **Muster Roll** – this checks the number of days worked for and therefore determine how much to be paid to a worker.
 - This record shows the name of the worker, payroll number, days worked for, rate of payment, the amount of salary and signature.

Muster Roll

Name of Person	Pay Roll No.	Days					Days Worked	Rate of Pay (kshs)	Total Pay (Kshs)	Signature of Workers
		1	2	3	4	5				
Mr. X	08						25	@100/ -	2,500/-	
Mr. Y	09						25	@100/ -	2,500/-	

-Labour Utilisation Analysis. They show how labour is utilized on the farm and helps to determine labour allocation; labour requirement for the purpose of budgeting when labour is in peak demand or when to lay off unproductive labour.

No of hours Worked	Livestock Production	Crop Production	Machinery Maintenance	Date of Working	Remarks
--------------------	----------------------	-----------------	-----------------------	-----------------	---------

Total cost

CROP PRODUCTION 1

LAND PREPARATION

Land preparation involves all the activities that make land suitable for planting such as

- -ploughing/digging
- -harrowing
- -ridging
- -rolling etc

A piece of land that has been prepared for planting is called seedbed. In a seedbed the planting materials germinate and grow to maturity and are harvested from same place.

IMPORTANCE OF LAND PREPARATION

- -To kill the weeds.
- -Encourage water infiltration into the soil.
- -To aerate the soil.
- -Incorporate manure and other organic matter into the soil.
- -To destroy stages of crop pests such as eggs, larvae, pupa or adults burying them, exposing them to the sun's heat or predators and starving them.
- -To encourage root penetration into the soil.
- -To make subsequent operations possible e.g. planting, fertilizer application, rolling and ridging.

OPERATIONS IN LAND PREPARATIONS

They include;

- A. Land clearing.
- B. Primary cultivation.
- C. Secondary cultivation.
- D. Tertiary operations.

A. LAND CLEARING

This is the removal of vegetation cover from the surface before tillage. This is done to prepare land for cultivation and as method of land reclamation. Land clearing is necessary under the following conditions.

1. When opening up a virgin land.
2. Where a stalk growing crop was previously planted such as maize.
3. Where land was left fallow for long time.
4. Where the interval between primary and secondary cultivation is long such that the land has reverted to the original virgin state.

Methods of Land Clearing

- *Tree felling.* Axes, pangas and power saws are used to cut down trees. Bulldozers and root rakers are used in felling trees on a large scale. Removal of stumps and trash later follows.
- *Burning.* The vegetation cover is set ablaze. The method should be discouraged as it destroys the soil organic matter, soil micro organisms and plant nutrients.
- *Slashing.* This is done to cut small bushes and grasses using slashers, pangas or tractor drawn mowers.
- *Use of chemicals.* Chemicals used to kill weeds are called herbicides.

B. Primary Cultivation

This follows land clearing,

- Small scale farmers use jembes or fork jembes during hand digging.

- In Large scale framing ploughing is done using mouldboard or disc plough.
- Other farmers use ox ploughs.
- Primary cultivation should be done before the onset of the rains. This ensures that all other subsequent operations are done in good time.

Importance of Primary Cultivation

1. To remove weeds.
2. To bury organic matter for easy decomposition.
3. To facilitate water infiltration and aeration.
4. To destroy soil borne pests by exposing them to predators and the sun.
5. To make planting easy.

Methods of Primary Cultivation

1. *Hand digging.* This is done by use of jembes, mattocks and fork jembes to cut and turn the soil slices.
2. *Mechanical cultivation.* This is the use of tractor drawn implements such as mouldboard and disc ploughs. Subsoilers, cultivators and chisel ploughs are used to break the hard pan. Subsoiling is the process of cultivating the soil with the purpose of breaking up the hard pan. Hard pans may be formed due to continuous use of heavy machinery on the land.

Importance of subsoiling

- Breaking up the hard pan hence improving drainage.
- Improving soil aeration.
- Bringing to the surface leached minerals.
- Improve root penetration.

3. *Use of an oxplough.* This is the use of ploughs drawn by oxen, donkeys or camels. The method is faster and more efficient than hand cultivation. It's common in areas where land is fairly flat.

The following aspects should be considered when carrying out primary cultivation.

I) Time of Cultivation

Land should be prepared before the onset of the rains so as to;

- Give enough time for the weeds to dry up and decompose into organic matter.
- To allow CO₂ and other gases to diffuse out of the soil while being replaced by oxygen.
- Give enough time for subsequent operations to be done hence giving way to early planting.

II) Depth of Cultivation

This is determined by;

- *Type of crop to be planted.* Shallow rooted crops do not deep cultivation. Deep rooted crops require deep cultivation.
- *Type of the soil.* Heavy soils are hard when dry making jembes and fork-jembes to dig shallowly.
- *The implements available.* Tractor drawn implements give deeper depth than hand operated tools.

III) Choice of the Correct Implements

This is determined by:

- 1. Condition of the land.** If the land has a lot of stones and stumps, a disc plough is preferred because it rolls over the obstacles without braking.

2. **Type of the tilth required.** Very fine tilth requires different types of implements.
3. **Depth of cultivation.** When deep cultivation is required heavy implements are used. Light implements are used when shallow cultivation is needed.
4. **Topography of the land.** Tractor drawn implements cannot be used where the slope is very steep.
5. **Implements available.** A farmer can only use what is locally available.
6. **Shape of the land.** Some land shapes may not allow tractor drawn implements to be used efficiently e.g. where there are acute corners.
7. **Size of the land.**

C.Secondary Cultivation

- This follows primary tillage.
- This involves the refinement of the seedbed before planting.
- It is also referred to as harrowing.
- Small scale farmers can use pangas, jembes, fork-jembes, and garden rakes to break the soil clods and pulverize the soil.
- Large scale farmers use tractor drawn harrows such as disc harrows, spike toothed harrows, spring tine harrows.

IMPORTANCE OF SECONDARY CULTIVATION

- i. To remove any weeds that might have germinated immediately after primary cultivation.
- ii. To break the soil clods into small pieces for easy planting.
- iii. To level the field so as to obtain the uniform depth of planting.

- iv. Incorporate organic matter into the soil in order to encourage decomposition before planting.

Factors determining the number of times secondary cultivation is done.

- i. *Size of the planting materials.* Small seeds require a fine tilth than large seeds.
- ii. *Slope of the land.* If the land is hilly, less number of secondary cultivations are preferred to discourage soil erosion.
- iii. *Moisture content of the soil.* in dry soils less operations are preferred so as to conserve the soil moisture.
- iv. *Condition of the land after primary cultivation.* If after primary cultivation, a lot of trash is left, more harrowing operations should be carried out so as to incorporate the trash into the soil.

D. Tertiary Operations

- They are carried out to meet the needs of certain crops.
- They are conducted after land clearing, primary and secondary cultivations. They include;

i. Ridging

- This is the process of digging soil in a continuous line and heaping it on one side to form a ridge (bund) and a furrow.
- These ridges are used in planting crops such as Irish potatoes, cassava, groundnuts etc.
- *Ridges facilitate tuber expansion and easy harvesting of the root crops.*
- Furrows are made when planting sugarcane.
- *They help to conserve soil and water.*

ii. Rolling

- This is done to compact the soil which is loose or of fine tilth.
- This is done to *prevent small seeds from being blown away by the wind and to prevent soil erosion.*
- This also increase seed soil contact.
- Heavy rollers are used in large scale.

iii. Leveling

- This is making the soil surface flat and uniform to promote easy germination of small seeded crops.
- *Rolling ensures uniform germination of seeds.*

MINIMUM TILLAGE

This is the use of a combination of farming practices that disturb soil the least. These farming practices include;

- i. Application of herbicides in controlling weeds.
- ii. Timing cultivation/timely weeding of the previous crop.
- iii. Mulching. Mulch prevents weeds from growing.
- iv. Restricting cultivation to the area where seeds are to be planted. Weeds in the rest of the field are controlled by slashing.
- v. Establishing a cover crop on the field.
- vi. Uprooting or slashing weeds in perennial crops.

Reasons for carrying out minimum tillage

- i. Reduce the cost of cultivation. By reducing the number of operations.
- ii. To control soil erosion.
- iii. To maintain soil structure.
- iv. To conserve soil moisture. Continuous cultivation exposes the soil to sun's heat hence evaporation of soil moisture.
- v. To prevent root and underground structures disturbance.

- vi. To prevent exposure of humus to adverse conditions such as sun's heat that cause volatilization of nitrogen

Soil Fertility I: (Organic Manures)

Soil Fertility: This is the ability of the soil to provide the crops with the required nutrients in proper proportions for high production.

Characteristics of Fertile Soils

- i). *Good Depth:* Deep soil gives plants greater volume to obtain nutrients and also provide anchorage.
- ii). *Good water holding capacity:* This ensures that water is retained well for plant use.
- iii). *Proper drainage:* Well drained soils are well aerated facilitating healthy root development.
- iv). *Correct soil pH.* Different crops have different nutrient requirements.
- v). *Adequate nutrient supply.* It should supply the crops with the nutrients they require in adequate amounts.
- vi). *Free from excessive infestation of soil borne pests and diseases.*

How Soil Loses Fertility

- i. *Leaching.* Soluble minerals are carried to lower horizons beyond the reach of plant roots.
- ii. *Mono cropping.* Growing one type of crop continuously for a long time leads to the exhaustion of certain minerals that the plant uses.
- iii. *Change of soil pH.* Changes in the soil pH affect the activity of the soil microorganisms and the availability of certain soil nutrients. Use of some fertilizers can change the soil pH.
- iv. *Continuous cropping.* Crops take up a lot of nutrients during their growth which are never returned to the soil. This makes the soil deficient of these plant nutrients.

- v. *Burning of vegetation cover.* This destroys the organic matter hence destruction of the soil structure.
- vi. *Soil erosion.* When the fertile top soil is carried away, the soil loses its fertility.
- vii. *Accumulation of salts.* This is as result of irregular rainfall and insufficient removal of salts from the soil especially in the arid and semi arid areas. Accumulation of salts is called salinisation

Maintenance of Soil Fertility

- i. **Control of soil erosion** to enhance soil infiltration onto the soil and reduce surface run off.
- ii. **Weed control** to prevent competition for nutrients. Water space and light with crops. It also reduces pests and diseases.
- iii. **Carrying out crop rotation**, this helps to control accumulation of crop pests and diseases on the farm. It also helps to ensure maximum utilization of nutrients.
- iv. **Use of inorganic fertilizers** helps to add nutrients to the soil e.g. CAN, DAP, Urea etc..
- v. **Use of organic manure** helps to supply organic matter to the soil.
- vi. **Minimum tillage** which helps to maintain soil structure and prevent soil erosion.
- vii. **Intercropping (Mixed cropping)** of leguminous and non-leguminous crops fix nutrients and improve fertility.
- viii. **Proper drainage** by breaking hard pans or creation of water channels this ensures proper aeration.
- ix. **Control of pH** to almost neutral to ensure proper functioning of micro-organisms which help in decomposition of organic matter.

Organic Manures

They are obtained from plant and an animal remains after decomposition.

Role/ Importance of Organic Matter

Improves soil structure – aeration, drainage absorption and retention.

- i) Improve water holding capacity of the soil.*
- ii) Increases soil fertility e.g. carbon nitrogen etc.*
- iii) It provides food and shelter to soil microorganisms.*
- iv) Help to keep PH of soil stable (Buffers soil pH).*
- v) Reduces toxicity of plant poisons that have build up in the soil as a result of continuous use of pesticides and fungicides etc.*
- vi) Humus gives soil dark appearance making the soil to absorb heat. This moderates soil temperature.*

Problems Associated with the use of Organic Manures

- 1. Bulkiness – they have low nutritive value per unit volume hence required in large volumes.*
- 2. Laborious in application and transportation – this is due to their bulkiness.*
- 3. They spread diseases, pests and weeds – i.e. if they are made from materials that are contaminated.*
- 4. Losses of Nutrients – if they are poorly stored, soluble nutrients are easily leached and some become volatilized when exposed to the hot sun.*
- 5. If used when not fully decomposed the plant does not benefit from them.*

Types of Organic Manures

They are of three types:

- Green Manure.
- Farm Yard Manure (FYM)
- Compost Manure.

Green Manure

- It is made of green plants which are left to grow until flowering and then are incorporated into the soil through

ploughing. The crops used include; cowpeas, groundnuts, Lucerne, beans, sunflower etc.

Characteristics of Plants used as Green Manure

- i). Should be leafy or highly vegetative.
- ii). Should have high nitrogen content hence leguminous ones are preferred.
- iii). Should have a fast growth.
- iv). Must be capable of rotting quickly.
- v). Should be hardy i.e. Capable of growing in poor conditions.

Reasons Why Green Manure is not Commonly Used

- i). Most crops used for green manure are food crops
- ii). Takes time for the manure to decompose delaying planting
- iii). Most of the nutrients are used up by micro-organisms in the process of decomposing the green manure
- iv). Green manure might use most of the soil moisture and leave very little for the next crop

Farm Yard Manure (FYM)

- This is mixture of animal waste (urine and dung) and crop remains used as animal beddings.
- The quality of Farm Yard Manure is determined by the following factors.
 - i). *Type of the animal used* –
 - Dung from fattening animals has a high level of nutrients than that from a dairy cow.
 - Non ruminants such as hens and pigs give very rich dung in terms of nutrients.
 - ii). *Type of food eaten* - nutritious feedstuffs give manure with more nutrients.

- iii). *Type of litter used* – wood shavings and sawdust are slow to decompose and contain very little nutrients as compared to leguminous ones which give manure rich in nutrients.
- iv). *Method of storage* – for manure to retain its nutritive status, it must be stored in place with a leak proof roof and a concrete floor.
- v). *Age of the farm yard manure* – well rotten manure is rich in nutrients and is easy to apply.

Preparation of the farm Yard Manure

- Provide materials such as grass or wood shavings in the animal house to serve as bedding.
- Animals deposit their droppings and urine on the bedding and mix them by trampling.
- After some time Collect the used animal bedding/litter and other rotten plant residues;
- Store collected materials under roof/shed to prevent leaching and oxidization of nutrients;
- Turnover the materials regularly;
- Sprinkle water if dry;
- Leave the material to rot completely before use

Compost Manure

- This is a type of manure made from decomposed materials such as kitchen refuse, plant and animal remains.
- The following factors are considered when selecting the site for making compost manure.
 - i). *Well drained place* – this avoids waterlogging which may cause leaching of nutrients.
 - ii). *Direction the prevailing wind* – this aims at preventing bad smells from being blown to the homestead.
 - iii). *Size of the Farm* –the site should be centrally placed on the farm.

- iv). *Accessibility* – this makes transportation of the manure possible.

Preparation of Compost Manure

- There are two methods of preparing compost manure;
 - Indore Method (pit Method)
 - Four Heap System (Stack Method).

Indore Method (pit Method)

- A pit 1.2m long by 1.2m wide and 1.2m deep is made.
- The materials to be composted are placed in layers in the following order;
- Fibrous materials such as maize stalks form the foundation.
- They are followed by a layer of grass, leaves or any kitchen refuse material.
- A layer of well rotten manure is then applied to provide nutrients for the microorganisms.
- A thin layer of wood ash is applied to improve the level of phosphorous and potassium in the manure.
- A layer of top soil is then added to introduce microorganisms that are required to decompose the organic materials..
- The above sequence of layers is repeated until the pit is full.
- A layer of soil is added to cover the pit.
- During the dry season, the materials should be kept moist by adding water.

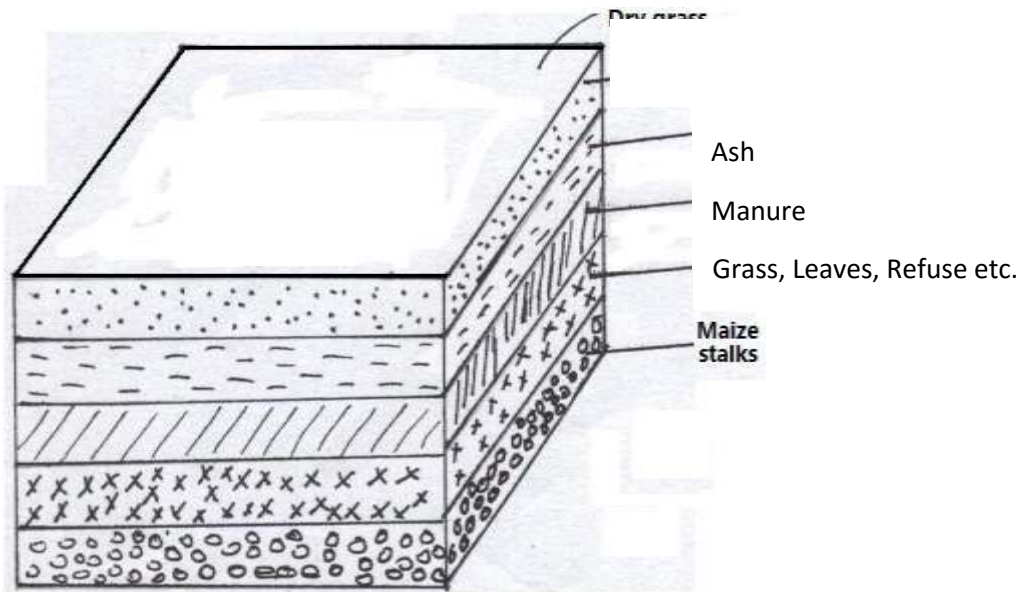

- Five pits are dug in series and materials filled as follows:
- Pits I, II, III and IV are filled with the materials as described above.
- After 3-4 weeks, the materials in pit IV are transferred to pit V, materials in pit III to IV, in pit II to pit III and in pit I to pit II.
- Process is repeated until the materials are well rotten then taken to the field as compost manure.

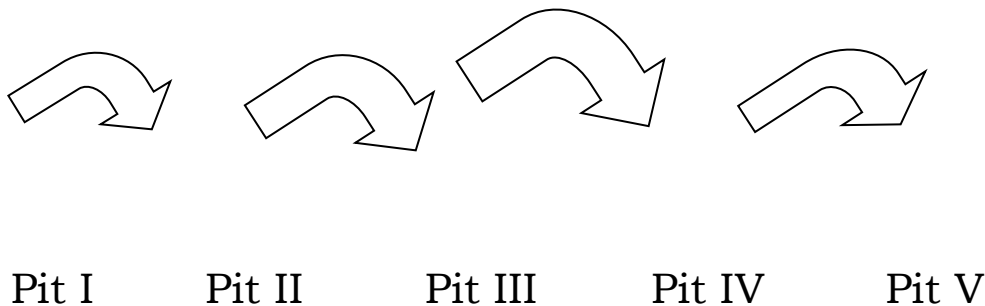

Four Heap System (Stack Method)

- In this method four heaps are used.
- The materials used are similar to those used in the pit method.

Construction

- Vegetation is cleared from the ground.

- Posts 2m high are fixed at a spacing of 1.2 by 1.2m forming the corners of the heap.
- Wood planks are fixed on the sides to form the walls and materials are arranged as in the Indore method.
- Materials are placed in the heaps labeled X and after 3-4 weeks they are transferred to pit Y.
- After another 3-4 weeks, the compost materials are transferred to pit Z where they stay for some 3-4 weeks before they become ready to be taken to the field.
- The manure should be turned occasionally to facilitate air circulation.
- A stick is driven into the stack an angle to check the temperature.
- If the temperature inside is high, it is corrected by adding water.

Diagrams

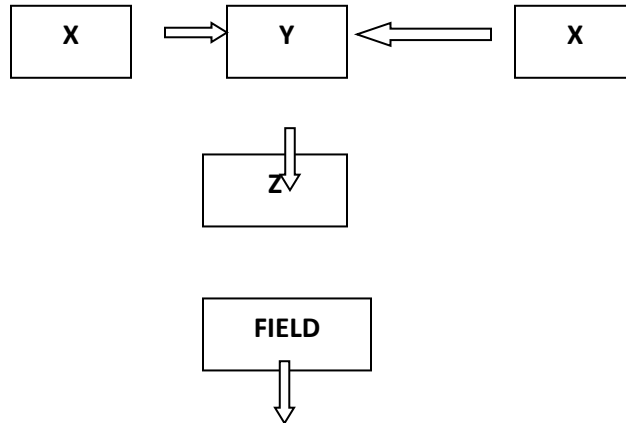

WATER SUPPLY, IRRIGATION AND DRAINAGE

WATER SUPPLY

The Hydrological Cycle

- Water from the surface evaporates up the atmosphere, cools and condenses to form clouds.

- Saturated clouds fall down to the earth as precipitation in form of rain.
- This water returns back to the atmospheres through the process of evapo-transpiration.
- The circulation of water from the earth's surface to the atmosphere and back again is called the ***Hydrological Cycle***

Sources of Water

- They include; surface water sources, underground water sources and rain.

1. Surface water sources

They include;

- **Rivers, streams and dams.**
- **Lakes**

2. Underground water sources

They include:

- **Springs.**
- **Wells.**
- **Boreholes.**

Assignment.

Make short notes on the various sources of surface and underground water.

3. Rain water.

This is collected from rooftops and stored in tanks. Ponds can also be dug to collect the runoff. Rain water is very pure compared to the other sources.

Water Collection and Storage

i) Dams.

- A dam is a barrier constructed to store water. Dams can be made of earth or concrete.
- Grass should be planted on the embankment to prevent soil erosion.

ii) Weirs.

- Weirs are used to raise the water level in a river to facilitate pumping.

iii) Water tanks.

These are made of concrete, stone, metal sheets, plastic or rubber. They should be covered to prevent water contamination.

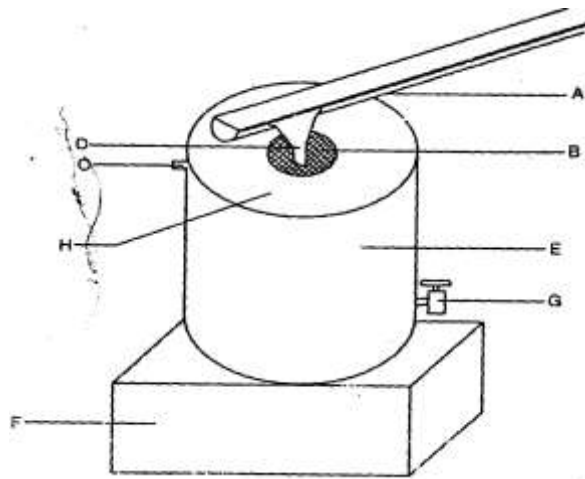

Pumps Water

lifting
point to another by use of mechanical force.

and Pumping of

- Pumping is the of water from one

Types of water pumps

- Centrifugal/ rotodynamic pumps.*
- Piston/ reciprocating pumps.*
- Semi-rotary pumps.*
- Hydrum.*

Conveyance of Water

- This is the process of moving water from one point (source or storage point) to where it will be used or stored. This can be done through;

i) **Piping**

- In this case water moves through pipes.

Types and choices of pipes

- **Metal pipes**

These are expensive but durable. They also can withstand high pressure.

- **Plastic pipes**

They are cheap and easy to install. However they can burst under high water pressure, can break when exposed to the sun and can be gnawed by rodents such as moles.

- **Hose pipes**

They are either made of rubber or plastic. Rubber ones are more expensive and more durable than the plastic ones.

- ii) Use of containers*

Containers such as jerry cans, drums and pots are used to draw water and are carried by various means such as bicycles and animals.

- iii) Use of canals*

Water is conveyed from a high point to a lower point along a slope especially for irrigation purposes.

General Uses of Water on the Farm

- i. Domestic use – cooking, drinking, washing
- ii. Cooling animals
- iii. Rearing fish
- iv. Watering/ irrigation plants
- v. Cleaning calf pens, milking sheds
- vi. Watering livestock / drinking
- vii. Diluting / dissolving chemical used to control pests, parasites and weeds
- viii. Mixing concrete in construction
- ix. Cooling and running machine engines
- x. Processing farm produce eg coffee hides, carrots
- xi. Recreation eg swimming pools

WATER TREATMENT

Importance of Water Treatment

- i) Kill disease causing microorganisms.
- ii) Remove chemical impurities such as excess fluoride.
- iii) Remove bad smells and bad tastes.
- iv) Remove sediments of solid particles such as soil and sand.

Process of Water Treatment

Stage I: Filtration of water intake.

- Water from Source River is made to pass through a series of sieves.
- Large particles of impurities are trapped by the sieves.
- Water then enters into the large pipe to be directed to the mixing chamber.

Stage II: Softening of the water

- Water circulates in the mixing chamber and doses of soda ash to soften the water.

Stage III: Coagulation and sedimentation

- Water is passed through coagulation tank where fresh air enters to remove bad smell/ chloride of lime used.
- Water stays for 36 hours thus solid particles settle and bilharzias causing organisms killed.
- Alum is added to coagulate solid particles which settle at the bottom.

Stage IV: Filtration

- Water is passed through filtration tank with layers of sand and gravel to filter it.
- Water leaving the filtration tank is clean.

Stage V: Chlorination

- Water is passed through chlorination tank where chlorine is added.
- Micro-organisms in the water are killed by chlorine.

Stage VI: Storage - The treated water is stored in large overhead tanks before distribution and use.

Diagram

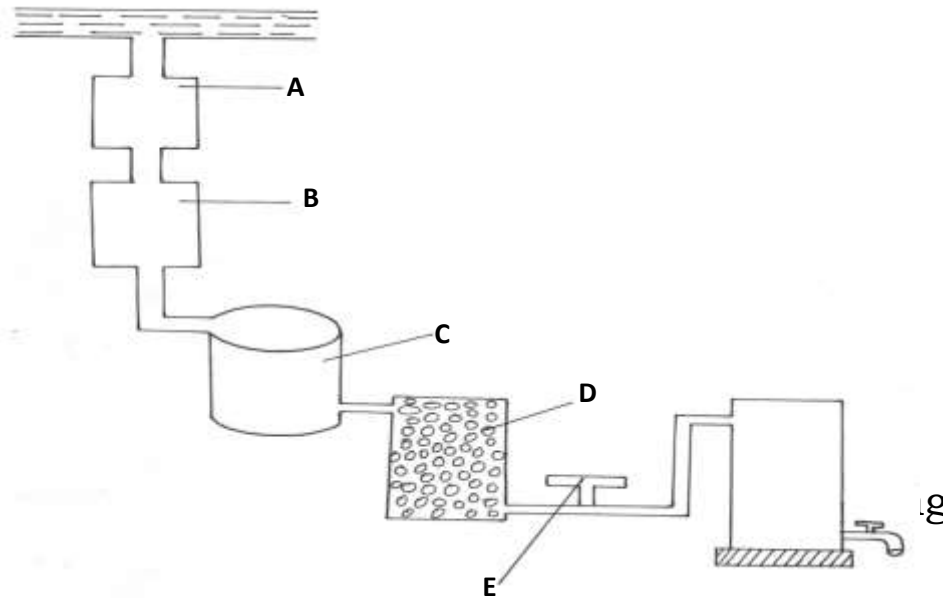

Water Treatment

- Boil
bilh

IRRIGATION

- This is the artificial application of water to the soil to supply crops with sufficient moisture for growth.
- It is usually practiced;
 - i) *In dry areas.*
 - ii) *During dry periods.*
 - iii) *In the growing of paddy rice.*

General importance's of Irrigation.

1. *Enable crop production during dry season*
2. *Reclaim arid and semi arid land for farming*
3. *Supplement rainfall in crop production*
4. *Help provides enough water to crops that require a lot of water like rice*
5. *Creates favourable temperature for proper plant growth*
6. *Enable supply of fertilizer in irrigation water*
7. *Make possible to grow crops in special structures like green house*

Types of Irrigation

Factors considered when choosing type of irrigation system

1. *Capital availability*- this determines the type of irrigation systems to be used. Drip and overhead irrigation systems require high capital for installation and maintenance
2. *Topography*- Surface irrigation requires flat areas
3. *Water availability*- Surface irrigation requires a lot of water. Drip and overhead irrigation requires less water
4. *The type of soil*- Surface irrigation is best suited for clay soils because they retain water for a long time.
5. *The type of crop / value of the crop / benefit analysis*. Crop to be irrigated should be of high value to justify the irrigation cost
6. *The availability of clean water* – drip and overhead irrigation requires clean water to prevent blockage of the systems

A. Surface Irrigation

- Water is brought to the crop fields from the source by use of canals or furrows. The following methods are used here; Flood Irrigation, Furrow Irrigation and Basin Irrigation.
- The following factors are considered when choosing the method to use in surface irrigation.
 1. *Topography*- Surface irrigation requires flat areas
 2. *Water availability*- Surface irrigation requires a lot of water.
 3. *The type of soil*- Surface irrigation is best suited for clay soils because they retain water for a long time.

Flood Irrigation

- The entire field is flooded with water.
- The method is cheap to establish and maintain but there is uneven distribution of water to crops and a lot of water is wasted.

Furrow Irrigation

- Irrigation water flows from canals into furrows..
- Furrows should be maintained by repairing when eroded or worn out, removing the weeds and silt.

Advantages

- Cheap to establish and maintain.
- Requires little skill to maintain.
- Reduces fungal diseases such as blight since there is no wetness on the leaves.

Disadvantages

- Soil erosion may occur.
- A lot of water is lost through evaporation and seepage.

Basin Irrigation

- An area enclosed by walls called embankments/levees is flooded. The method is common in the rice growing areas. Such as Mwea Tebere, Ahero, Bunyala etc.

B. Sub-Surface Irrigation and Drip/Trickle Irrigation

- This involves laying perforated pipes underground to allow water to pass out through tiny holes and wet the soil around the zones of the crop.

Advantages

- Minimizes labour requirement especially in changing of water pipes.
- Minimizes possible theft of water pipes.
- Economizes on the use of water.
- Can be practiced on both sloppy and flat land.
- There is no soil erosion.
- No growth of weed between the rows.
- Water under low pressure can be used as long as it can flow along the pipes.

- Controls fungal diseases such as blight because water does not accumulate on the leaves.
- There is no need of constructing dykes, leveling or making

Disadvantages

- Expensive to install.
- Pipes can be broken during weeding or land preparation.
- Nozzles can get blocked making irrigation inefficient hence the method requires clean water.

C. Overhead/Sprinkler Irrigation

- In this case water is applied to the plants in form of spray using sprinklers or watering cans.
- The sprinklers and pipes used must be maintained as follows.
 - Lubricating the rotating parts to reduce friction.
 - Repairing any broken parts.
 - Cleaning to unblock the nozzles.

Advantages of sprinkler irrigation

1. There is even distribution of water over the area required
2. Less water is required / less water wastage
3. Can be practiced on sloppy land
4. It is possible to apply foliar fertilizers with irrigation water / fertigation
5. Irrigation pipes / sprinklers can easily be moved from one area to another
6. Irrigation water cleans off dust from plant leaves for better functioning
7. Helps to control aphids.

Disadvantages

- i. Expensive to install.
- ii. Encourages fungal diseases such as blight and coffee berry disease due to wetting of the leaves.

- iii. Can cause soil erosion if not well controlled especially on sloppy ground.
- iv. May require the establishment of a wind break.
- v. Maintenance is expensive as it requires a lot of skill

Factors considered in choosing irrigation water pipes

1. Durability- Shown by the quality of the materials the pipes are made of
2. Length of the pipes- This is determined by the size of the farm and the source of water / water supply point.
3. Diameter of the pipe- Determines the volume of water to be conveyed in the pipes
4. Water pressure- High water pressure requires strong pipes to prevent bursting
5. Resistance to heat from the sun- Pipes crack and become brittle if exposed to the sun
6. Resistance to pest damage- Plastic pipes are easily damaged / gnawed by rodents
7. Cost of the pipes- Aluminium pipes may be expensive when used for irrigation

Drainage

- This is the removal of excess water from waterlogged land. It is done to reclaim marshy areas for agricultural production.

Importance of Drainage

- i. **To increase soil aeration.** When excess water is removed from the soil, plant roots get enough air for growth.
- ii. **Increase soil volume.** Drainage increases the amount of soil around the root zone making it possible for plants to obtain nutrients.
- iii. **Raise soil temperature.** Drainage improves the aeration at which the soil becomes warm for maximum plant growth.

- iv. **Increase microbial activities.** Proper aeration as a result of drainage increases the number of microorganisms in the soil.
- v. **Reduce soil erosion.** Well drained soils have high water holding capacity which helps to reduce surface run-off increasing the infiltration rate.
- vi. **Remove toxic substances.** When there is water-logging, salts accumulate to toxic levels in the soil. Drainage removes such salts from the soil.

Methods of drainage

a) Use of open ditches/channels/furrows.

- Ditches are dug for water to flow by gravity lowering the water table.

b) Use of underground pipes

- Perforated pipes are laid underground and water seeps into them, then flows to a water way. The pipes are made of plastic, metal (steel) or clay.

c) French drains

- Ditches are dug and filed with stones and gravel and then covered with soil.
- Water from the surrounding area seeps into them the flows to a water way.

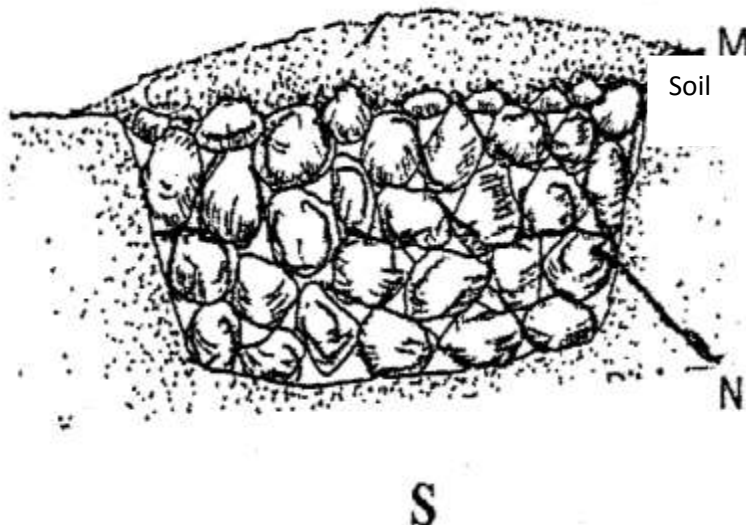

d) Cambered beds

- Raised beds are constructed in combination with ditches in the poorly drained soil such as the black cotton soil.

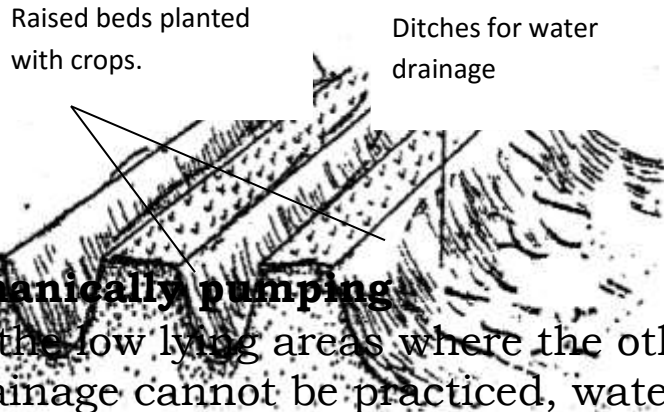

e) Mechanically pumping

- In the low lying areas where the other methods of drainage cannot be practiced, water is mechanically pumped out of the soil.

f) Planting of Trees

- Trees such as eucalyptus can be planted in water logged areas as they lose a lot of water through transpiration.

Water Pollution

This is the introduction of harmful substances into the water.

Agricultural Practices that Pollute Water

a) Use of inorganic fertilizers

Fertilizers used get leached through the soil and are carried to water bodies.

b) Use of pesticides

Excess pesticides seep into the soil and find their way to the water bodies causing pollution.

c) Poor cultivation practices. These practices include:

- *Over cultivation.* This causes soil erosion hence siltation in water bodies.

- *Overgrazing*. This also causes soil erosion hence pollution in water bodies.
- *Cultivation along the riverbanks*. Also causes soil erosion hence siltation in water bodies.

Methods of Preventing water Pollution

1. Soil conservation measures to minimize soil erosion.
2. Fencing of water sources to minimize pollution by animals.
3. Enforcing integrated ways of controlling pest and weeds that do not use chemicals such organic farming.
4. Planting vegetation along the river banks to avoid siltation.
5. Using adequate storm control methods in the areas experiencing heavy rains.

FARM TOOLS AND EQUIPMENT REVISION QUESTIONS

- 1 The diagrams below are of farm tools and equipment. Study them and answer the questions that follow

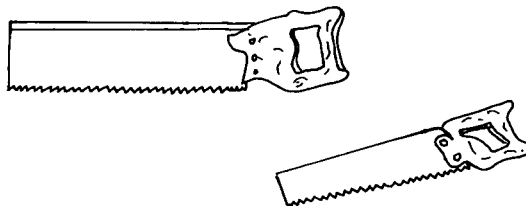

- i) Identify the tools 1 mk
- ii) Give one functional difference between the tools above.
1 mk

2. The diagram below show farm equipment. Use them to answer the questions that follow.

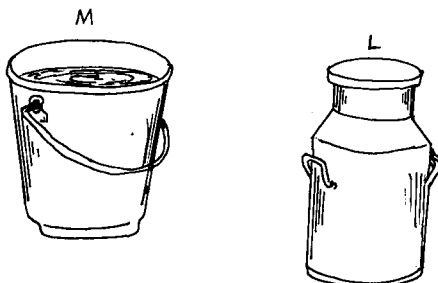

- a) Identify the equipments M and L. (1mk)
- b) State the functional difference between M and L. (2mks)
- c) State TWO common maintenance practices carried out on both M and L. (2mks)

3. The diagram below shows a farm equipment study it and answers the questions that follow.

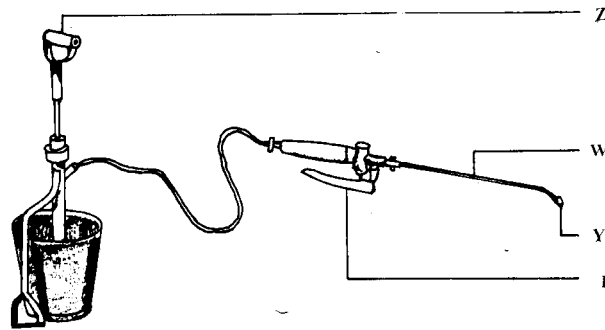

[a] Identify the equipment. [1mk]

[b] Name the parts labeled. [2mks]

W; X ; Y; Z

[c] What is the function of the part labelled Z. [1mk]

4. **Study** the diagrams below and answer the questions that follow.

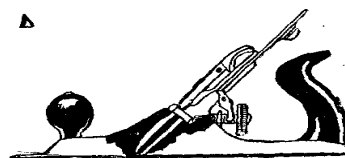
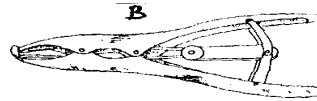

- (a) **Identify** the tools. A-B-C-D
(2mks)
- (b) **State** the correct use of each of the tools above.
(2mks)
- (c) **Give two** maintenance practices carried out on tool **D** for efficient use. (1mk)

5 (a) **Name four** types of tools used in smoothing wood.
(2mks)

(b) **Give three** reasons why farm tools and equipment should be well maintained. (1¹/₂mk)

6. Below is a diagram of farm equipment. Use it to answer the questions that follow.

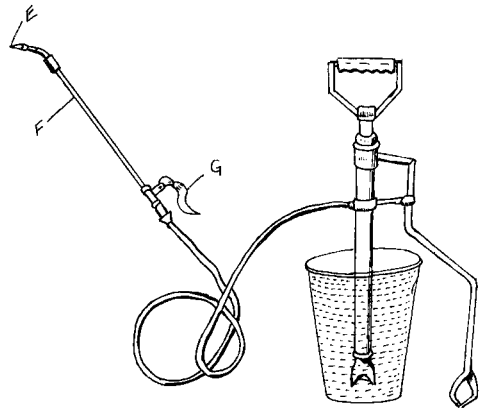

- a) Identify the equipment. (1/2 mk)
- (b) State two reasons for your choice in (a) above
(1mk)
- b) State the use of the equipment
(1mk)
- c) Name the parts labelled G,E and F. (1 1/2 mks)

d) Identify two draw backs in using this equipment compared to others that may be used for the same purpose. (2mks)

7. Identify the farm tool and equipment illustrated in the diagram labeled k and L and give one use of each equipment.

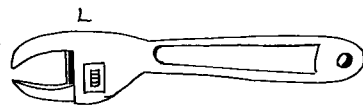
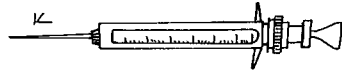

Equipment	Identity	Use
(a) K
L

(b) Give the care and maintenance of L (1mk)

8. Observe the tools X and Y illustrated below and answer the questions that follow:-

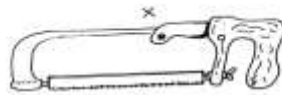

a) Identify the tools. X ; Y (2 mks)

b) State one use of each of the following tools. X;Y (2 mks)

c) State three maintenance practices carried out on tool X.
(3 mks)

9. The diagram below illustrate a workshop tool



a) **Identify** the tool.....
(1mk)

b) **Name the parts** labeled **S, T and U**
(3mks)

c) **State** the use of the tool
(1mk)

10. Study the diagrams of livestock production tools below and answer questions that follow.

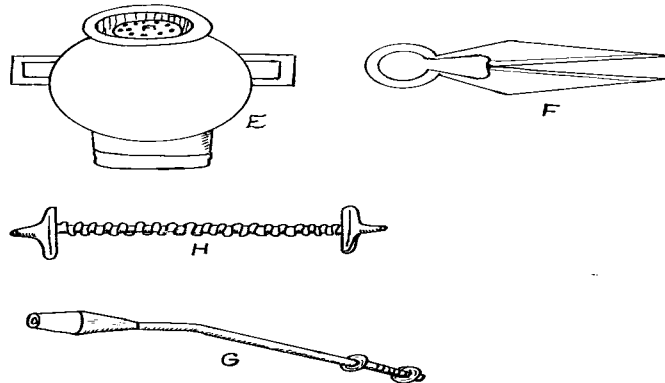

a) Identify the tools E, F, G and H. (4mks)

b) State two maintenance practice of the equipment E.
(2mks)

11. Below are diagrams of workshop tools.

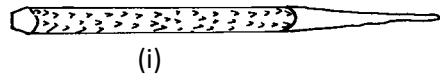

(i)



(ii)

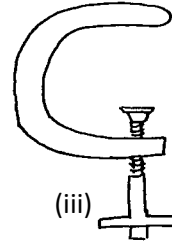

(iii)

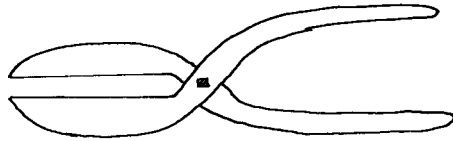

(iv)

State the functions of tools.

(4mks)

(i).....

(ii).....

.....

(iii).....

.....

(iv).....

.....

b) What is the name given to the metallic brush which is used to clean out wood chippings from tool (i) above.

12 Study the diagrams of garden tools shown below and answer the question that follo

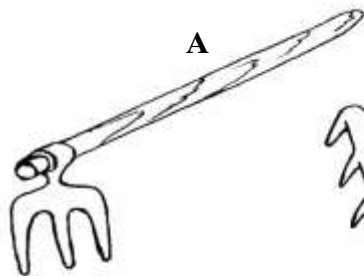

A

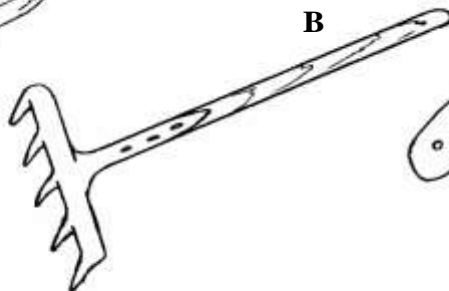

B

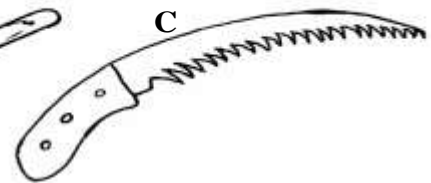

C

(i) **State two** field conditions under which tool **A** would be more suitable for use in crop

Production

(2mks)

(ii) **Give** the function of the tool labelled **C**.
(1mk)

(iii) **State two** maintenance practices of the tool labelled **B**.
(2mks)

13. Study the diagrams below labeled P,Q,R and S representing some workshop tools and then answer the questions that follow.

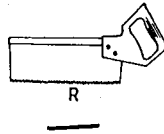
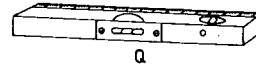

a) identify the tools

2mks

Tool

Name

P

Q

R

S

b) Give one use of tools P and R in the construction of a wooden feed trough. 1mk

P

R

- c) How would the tool labelled Q be used in the construction of a calf pen? ½ mk
- d) Give two maintenance practices carried out on tool S.
1mk

14. Study the diagram below of farm tools and equipment and answer questions that follow.



- (i) Identify tool M and N
(1mk)
M.....
N.....
- (ii) State **one** functional difference between M and N
(1mk)
- (iii) State **two** maintenance practices of tool M.
(1mk)

FARM TOOLS ANSWERS

- 1 A)
Tenon / back saw
Cross – cut saw/ rip saw/ hand saw
(1 mk)
- b) Tenon saw- For cutting tenon joints / fine sawing reject cutting joints alone
Cross cut- saw cutting across the grains of wood
(2 mks)
- 2 a) M – milking bucket / pail (reject milk bucket / pail)

L- Milk churn / can (reject milking churn)

2 x

$\frac{1}{2} = 1\text{mks}$

b) M – used for holding milk during milking

2 x

1 = 2mks

L – Used for holding milk during transportation

c) i) Washing thoroughly with hot water

2 x 1=

2mks

ii) Sterilizing using recommended detergent

4 .(a) A-garden trowel

B-elastrator

C- Plumb bob/ plumb line

D- Jack plane

($\frac{1}{2} \times 4$)

(b)

Tool	use
A	-for lifting seedlings from the nursery during transplanting.
B	-for applying/ fixing the rubber ring during castration docking or dehorning
C	-checks the vertical straightness of a stone wall during castration.
D	-for smoothening rough wood surfaces.

(c)

- ❖ Sharpening the blades regularly
- ❖ Replacing broken handles and knob

- ❖ Tightening loose parts (screws)
- ❖ Adjusting appropriately the lever cap.
(½ x 2)

6. a) - Stir-up pump. √½
- b) - Spraying livestock √1
- c) - E-Trigger √½
 - F-Nozzle √½
 - G-(Brass) lance. √½
 1 ½mk
- d) - Need two people to operate. √1
 - Not easy to carry about during operation. √1
 1 x 2=2mk

Equipment	Identify	Use
K	- Hypodermic syringe / syringe And needle	- Inject Animals to introduce Drug or vaccine
L	- Adjustable spanner	- Holding different sizes of nuts and bolts (Accept tightening / loosening)

9. (i) Auger bit (1 x 1 = 1mk)
- (ii) S – shank
 T-Twist threads
 U-Spur (3 x 1 = 3mks)

(iii) Making holes (boring holes on the wood)
(1mk)

12 (i) **Conditions under which tool labeled A is used**

- Hard ground/ soils
- A stony field
- Field with rhizomes/stolons/ roots
- A field with sticky soils(2x1 =2mks)

(ii) Functions of the tool labeled C

- Cutting pruning undesirable branches/ stems of trees/fruits/coffee/
- Cutting pruning excessive vegetative parts(1x1 =1mk)

(iii) Maintenance practices of tool labeled B

- Clean /remove soil/trash after use
- Straighten the prongs if bend
- Replace the handle if broken
- Fix the handle firmly on the rake(2x1 =2mks)

13.a)

Tool	Name
P	Try square
Q	Spirit level
R	Tenon saw/back saw
S	Cold chisel

½ x

4=2 MKS

b) Use of tools P and R in the construction of a wooden feed trough

P-Measuring angles/ layout of angles/
measuring lengths

R- Cutting timber to make joints/ used for
joinery work

-Fine cutting/ sawing

$\frac{1}{2} \times 1 = 1/2 \text{mk}$

- c) Use of Q in the construction of a calf pen
To determine if the floor level/ the walls are vertical.

$\frac{1}{2} \times 1 = \frac{1}{2} \text{mk}$

- d) Maintenance practices on tool S
-Sharpening the cutting edge
-Removing the mushroom head

$\frac{1}{2} \times 2 = 2 \text{mks}$

- 14 i) M- hack saw
N- hand saw

ii) Functional differences between M and N

- hack saw (M) is used for cutting metal rods and plates
while (N) hand saw is used for cutting wood/timber

(1x1=1mk)

iii) maintenance practices

- tighten loose screws and nuts (ref.bolt)
- replace worn out blade
- regular cleaning
- hang properly to avoid possible damage
- maintain correct tension of the blade

OTHER REVISION QUESTIONS

1. a). What is Agriculture?

b). State the roles played by agriculture in national development

d). i) Briefly outline the problems that have hindered agricultural development in Kenya.

- ii) Suggest ways in which these problems can be alleviated
2. a) i) What are the characteristics of shifting cultivation?
 ii) State the problems associated with shifting cultivation.
- b) What is pastoralism?
 c) State the factors to consider in choosing a type of farm
 d) What is arable farming?
 e) i) State the advantages of mixed farming
 ii) State the limitations of mixed farming
 f) i) Give the types of farming practised by small scale farmers
 ii) Name the types of large scale farming
 iii) Why does the Kenya government put a lot of emphasis on ranching?
 iv) State the common features of ranching as a farming system:
 g) i) State the advantages of plantation farming
 ii) State the disadvantages of plantations.
 iii) State the major characteristics of plantation farming.
3. a) List the ecological factors affecting agriculture.
 b) Mention the aspects of rainfall which are important in crop production
 c) i) What is optimal temperature?
 ii) State the effects of high temperature on crop production.
 d) State the negative effects of wind to crops.
4. a). i. Define the term soil
 ii). Name the ways in which soil is important to growing plants.
 b). i) State the factors which influence the soil forming process
 ii). What biological agents influence the speed of the soil forming process?
 c) i) Define the term soil Profile
 ii) How does soil profile influence plant growth?

- d) i) List the constituents of a fertile soil.
 - ii) What role do micro-organisms play in soil?
 - e) i) What is soil structure?
 - ii) State the farming practices that improve soil structure.
 - iii) Why is a good soil structure desirable for growing crops.
 - f) i) What is soil texture?
 - ii) State the properties of soil that are influenced by its texture.
 - iii) Give the types of soil based on texture.
5. a) State the advantages of using farm tools.
- b) List the factors that determine a farmer's choice of tools and equipment.
- c) i) Why should tools and equipment to maintained well?
- ii) How should tools and equipment be maintained?
- d) List the safety precautions necessary for tools and equipment
- e) Name the categories of farm tools and equipment.
6. a) State the importance of land preparation.
- b) i) What is primary cultivation?
- ii) Which factors influence choice of tools for primary cultivation.
- c) i) What is secondary cultivation?
- ii) Give reasons for secondary cultivation?
- d) i) Define minimum tillage
- iii) State reasons for practising minimum tillage.
- e) Name the factors that determine the number of tillage operations during seedbed preparation.
7. a) List the sources of water on the farm.
- b) How is water conveyed from one point to another?
- c) i) Name the types of water pipes.

- iii) What features are considered when buying plastic pipes?
 - d) Name the types of water pumps to be used on the farm.
 - e) i) Why should water be treated before use?
 - ii) State the methods of treating water on the farm.
 - iii) How is water used on the farm?
8. a) i) What is irrigation?
- ii) List the factors to consider in deciding to irrigate crops.
- b) List the major types of irrigation
9. a) i) What are the uses of farm records
- b) List types of records kept on mixed farms.
 - c) List types of records kept by crop farmers.
 - , goat, pigs, bees, fish, donkey, camel
- 10 b) i) Explain the role of livestock in human life
- ii) List factors that affect livestock industry in Kenya.
 - c) i) List dairy breeds of cattle
 - ii) State their characteristics.
 - d) i) Name beef cattle breeds.
 - ii) What are the characteristics of beef cattle.
 - e) Name the important rabbit breeds in Kenya.
 - f) Name the major breeds of sheep in Kenya and indicate the purpose they are kept for
 - g) Name important goat breeds and their uses
 - h) Name important pig breeds kept in Kenya.
 - i) i) Give the meanings of exotic and to indigenous breeds.
 - ii) State the characteristics of exotic cattle that make them better suited to marginal areas than exotic cattle breeds.
 - iii) What are the advantages of keeping a Jersey cow instead of Friesian for production of milk?
 - j) i) State the general characteristics of exotic cattle breeds.
 - ii) Give the characteristics of indigenous cattle

11. Below is a diagram of a nursery for raising the seedlings.

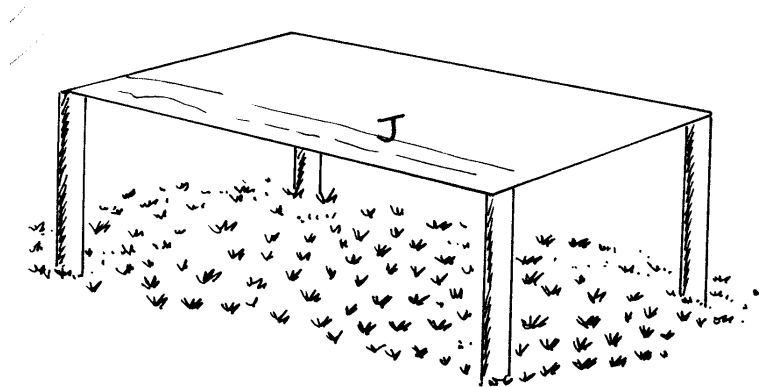

- (a) State two advantages of having the part labeled J
(2mks)*Nrk*
- (b) State any 3 management practices that should be carried out on the nursery from the time seedlings emerge to the stage of transplanting

3mks)*Nrk*

12. a) i) What is soil fertility?
ii) State the characteristics of a fertile soil.
iii) How can a fertile soil loss its fertility
iv). State the ways of maintaining or improving soil fertility
- b) i) What are plant nutrients?
ii) Name the major plant nutrients (macro-nutrients)
- c) State the roles and deficiency of the following nutrients in plants.
- i) Nitrogen uses
- Deficiency.
 - Excessive supply
- ii) Phosphorous used.
- Deficiency
- iii) Potassium uses.
Deficiency.
- d) i) What is soil sampling?

- ii) List the methods of soil sampling.
 - iii) State the reasons for soil testing:
 - iv) Explain the procedure of soil sampling:
 - v) State precautions necessary during soils sampling
 - vi) Name the methods of detecting nutrient deficiency in crops:
 - iv) State the importance of soil PH to a crop:
- 13 a) i) Differentiate between manure and fertilizer:
- ii) List the common organic manures
 - b). i) What is organic matter?
 - ii) State the importance of organic matter
 - iii) How can organic matter be added to soil?
 - c) i) Describe how to make farm Yard manure:
 - ii) State the factors determining quality of farm yard manure
 - iii) Give the advantages of using Farm Yard Manure over fertilizer:
 - iv) Give the disadvantages of using farm yard manure
 - d) i) State the factors to consider when citing a compost pit.
 - ii) Describe how to make compost manure
 - e) i) How is green manuring done on the farm?
 - ii) List the characteristics of green manure crops:
 - iii) What are the advantages of green manuring?
- 14a) Classify fertilizers by nutrient content.
- b) i) Name the common nitrogenous fertilizers.
 - ii) State properties of nitrogenous fertilizers/ (characteristics)
 - iii) When are they applied and why at that time?
 - c) i) Name the common phosphatic fertilizers:
 - ii) When are they applied and why at the time?
 - b) i) Name the common potassic fertilizers
 - ii) Characteristics:
 - c) i) What is fertilizer application?
 - ii) List the methods of fertilizer application:
 - iii) What is top dressing?

- d) i) Calculate the amount of K_2O (potassium chloride) contained in 400 kg of a compound fertilizer 25:10:5 – 5kg of K_2O is contained in 100kg of 25:10:5
- ii) A farmer is to apply a compound fertilizer 20:30:10 on a vegetable plot measuring 5 metres long by 4 metres wide, at the rate of 200kg per hectare.
- a) Calculate the amount of the fertilizer the farmer would require for the plot. (show your working)
- b) What do the figures 20, 30 and 10 in the fertilizer stand for
- iii) How much of a fertilizer labeled (20:20:10) should be applied to a plot which requires 30 kg P_2O_5 ?
15. a) i) State the importance of the nitrogen cycle
- ii) Describe the nitrogen cycle:
- iii) What happens to nitrogen in the soil?
- b) i) State the importance of carbon cycle
- ii) Describe the carbon cycle
- iii) How is carbon lost?
- iv) How can carbon be restored to the atmosphere?
16. a) i) Define crop propagation.
- ii) What are the methods of crop propagation?
- b) i) List the different methods of vegetative propagation:
- ii) State advantages of vegetative propagation.
- iii) State its disadvantages.
- c) i) What are the advantages of seed propagation
- ii) State the disadvantages of seed propagation
- d) i) Give the advantages of early planting
- ii) State the factors to consider when selecting seeds or other planting materials for planting
- iii) What are the reasons for seed selection?
- iv) What practices are carried out for seeds to ensure that they germinate?
- e) i) List the methods of planting
- ii) State the advantages of row planting.

- iii) State the factors which influence planting depth.
 - iv) What factors determine crop spacing?
 - v) State the advantages of correct spacing
 - vi) Why is correct plant population necessary?
 - f) Name the treatments necessary on planting materials before planting?
- 17a) What is a nursery?
- b) State the reasons for using a nursery.
 - c) State the nurseries management practices.
 - d) Explain the following nursery practices.
 - i) Pricking out.
 - ii) Hardening off.
 - iii) Rogueing.

FORM TWO AGRICULTURE NOTES

LIVESTOCK HEALTH II (PARASITES)

Parasite- A living organism that lives in or on another organism and obtains nourishment from that organism without being useful to it in any way.

-This host-parasite relationship is referred to as parasitism.

-Parasitism is an association between two organisms one a parasite and the other the host.

Effects of parasites on livestock

(i) Cause Anaemia

-Blood sucking parasites take large volumes of blood from the host animals leading to anaemia.

ii) Deprive the host of nutrients (food)

-Internal parasites compete for food with the host animals this results in loss of weight, emaciation and low production.

iii) Injury and damage to tissue and organs.

-Biting parasites break the skin of the animal exposing it to secondary infection.

-Some internal parasites such as round worms, liver fluke etc damage organs and tissues.

-Tissue injury results in hemorrhage.

iv) Disease transmission.

-Some parasites act as vectors of some diseases

-They spread disease from sick animals to healthy ones.

v) Cause irritation

-Some external parasites irritate the animals through their biting effects.

-This causes the animal to rub itself against solid objects destroying skin, fur or wool.

vi) Obstruction to internal organs

-Internal parasites may cause mechanical obstruction or blockage of the internal passages.

-This leads to mal-functioning of organs affected.

TYPES OF PARASITES

a. External parasites (ectoparasites)

b. Internal parasites (endoparasites)

a. External parasites

- Found on the outside of the host body.
- They may live on or under the skin.
- Most ectoparasites belong to the phylum arthropoda.
- There are two main classes of these parasites.

- Class insecta.
- Class arachnida

CLASS INSECTA

These consist of tse tse flies, keds, mosquitoes, flies, lice and fleas.

a. Tsetse fly (*Glossina* spp)

- This is a true insect undergoing complete metamorphosis i.e.
 - Tsetse flies give birth to larvae after the eggs hatch inside the body of the mother.
 - Larva forms the pupa, which later changes into an adult.
 - Tsetse flies bite mainly during the day.

Harmful effects

- They transmit Trypanosomiasis caused by a protozoan called trypanosome
- Sucks out blood from the animal causing anaemia.
- Cause damage on the skins and hides of animals making wounds which provide routes for secondary infection by pathogenic organisms.

Control

- Bush cleaning to destroy their breeding places.
- Spraying their breeding places with insecticides.
- Use of fly traps with impregnated nets.
- Use of sterilizing agents e.g. radio isotopes on male flies and then releasing them.

b. Keds (*Melophagus orinus*)

- Are sometimes referred to as sheep ticks.
- They are hairy and wingless bloodsucking flies.

Harmful effects

- Cause irritation in heavy infestation.
- Due to irritation, animal scratches itself thus damaging the wool.
- Retarded growth in lambs.
- Anaemia.

Control measures

- Shearing the infected sheep and hand spraying them with appropriate chemicals eg pyrethrum, malathion, dieldrin etc
- Routine sheep dipping.

c. Fleas

They are wingless but have strong legs adapted for leaping over long distances.

- They suck blood as their mouth parts are adapted for penetrating the host's skin and sucking blood.
- They pass through the following stages during development, egg- larvae- pupa- adult.

Harmful effects

- Cause irritation leading to scratching.
- Stick fast in poultry causing wounds on the comb and wattles.
- They cause anaemia.

Control measures

- Animals sleeping places should be kept clean.
- Dusting animal hooks with appropriate insecticides.
- Covering the stick fast fleas with petroleum to suffocate them.

d. lice

They are small wingless insects and can be divided into two groups.

- Biting lice (mallophaga)
- Sucking lice (anoplura)

Biting lice

- They are found on both the birds and mammals.
- They have chewing mouthparts.
- They complete their lifecycle between three to four weeks.

Sucking lice

- Have mouthparts reduced into styles for sucking blood.
- They are found only on mammals.

Harmful effects

- Cause irritation to the animal hence, the animal is seen to rub itself against fixed objects.
- Heavy infestations cause loss of health in animals.
 - Since animals under attack do not feed very well, there is emaciation.
- Loss of production in birds.
- Anaemia and restless especially in poultry.

Control measures

- Spraying or dusting animals with appropriate insecticides.
- Keeping animal houses clean.
- Perches in poultry houses should be applied with insecticides eg 40% nicotine sulphate solution.
- Dusting each bird with sodium fluoride for individual treatment.

CLASS ARACHNIDA

- This consists of the ticks, mites and spiders.

- Ticks and mites belong to the order Acarina.
- These do not undergo complete metamorphosis.
- They have two body parts i.e. cephalothorax and the abdomen.
- The adults have 4 pairs of legs.
- (a) Ticks.
- Ticks rank as the single most important ectoparasites of livestock.
- They cause injury and spread very dangerous diseases.
- There are over 50 different species of ticks known.

Harmful effects

- Vectors of diseases e.g. ECF, Red water, Anaplasmosis.
- Suck blood-causing anaemia to the host.
- Cause wounds through their bites.
- Cause irritation to the animal.
- Their bites lower value of hides and skins.
- Some ticks produce toxins that may be harmful to the host.

THE LIFE CYCLE OF TICKS

- Ticks usually pass through four main stages in their cycle i.e.
 - Egg
 - Larva (six legs)
 - Nymph (Eight legs)
 - Adult (Eight legs)
- Different species of ticks need different number of hosts.
- There are therefore three categories of ticks i.e.
 - One host ticks.
 - Two host ticks.
 - Three host ticks.

ONE HOST TICKS

- These ticks require one host to complete their lifecycle.
- Eggs on the ground hatch into larvae.
- Larvae climb onto the host, suck blood, become engorged and moult into nymphs.
- Nymphs feed on the same host, become engorged and moult into adults.
- Adults feed on the same host, mate and the females drop off to the ground to lay eggs.

Examples of one-host ticks:

- Blue tick (*Boophilus decoloratus*)
- The Texas Fever tick (*Boophilus annalatus*)
- The Cattle tick (*Boophilus microplus*)
- The Tropical Horse tick (*Dermacentor nitens*)

TWO HOST TICKS

- This tick requires two hosts to complete their lifecycle.
- The larvae and nymphs pass through their stages on the first host.
- Eggs on the ground hatch into larvae, which climb on to the first host.
- A larva attaches themselves to the host, feed on blood, become engorged and moult into nymphs.
- Nymphs feed on the same host become engorged and then drop to the ground to moult in adults.
- Adults find a new host on which to feed.
- They feed on the second host and mate.
- Females drop off to the ground to lay eggs.

Examples of two host ticks.

- Red legged tick (*Rhipicephalus evertsi*)
- The Brown tick (*Amblyomma maculatum*)
- The African Bont-legged tick (*Hyalomma truncatum*)
- Large Bont-legged tick (*Hyalomma rufipes*)

THREE HOST TICKS

- These ticks require three different hosts to enable them to complete their lifecycle.
- Eggs hatch on the ground into larvae.
- Larvae attaches itself to the first host, feed on blood, become engorged and drop off to the ground and moults into nymphs.
- The nymphs look for a second host, feed on blood, become engorged and drop off to the ground and moult into adults.
- Adults seek for the third host, climb, feed become engorged and mate.
- Females drop off to the ground to lay eggs.

Lifecycle of a three host tick.

Examples:-

- Brown ear tick (*Rhipicephalus appendiculants*)
- East African Bont tick (*Amblyomma variegatum*)
- Bont tick (*Amblyomma herbraem*)
- Gulf Coast tick (*Amblyomma maculatum*)
- Yellow Dog tick (*Haemaphysalis leachii*)
- Fowl tick (*Heamaphysalis hoodi*)
- Brown Dog Tick (*Rhipicephalus sanguineous*)

TICK CONTROL MEASURES

- Natural/Biological method.
- Mechanical method.
- Chemical method.
 - Natural/ Biological method.

-This is the use of the tick's natural enemies which predate on the ticks. E.g. using predators such as birds to control ticks.

N/B Only a small number of ticks is controlled using this method.

2. Mechanical method

i) Burning the infected pastures.

-Burning destroys eggs, larvae, nymphs and adults.

ii) Interfering with the ticks environment

This is achieved by:-

-Ploughing pasture land .the eggs are exposed to the sun heat or are deeply buried.

iii) By top dressing pasture using lime or dressing using acaricides.

iv) Fencing off the pasture and farm.

v) Hand picking the ticks (deticking)

vi) Starving the ticks to death

-This is achieved by practicing rotational grazing.

-It interrupts the lifecycle of the ticks.

3. Chemical control method.

This is done by application of acaricide.

Properties of an effective acaricide

-Has the ability to kill ticks.

-Be harmless to both human and livestock.

-Be stable.

-Should remain effective after having been fouled with dung, mud or hair.

Methods of acaricide application

-Spraying regularly with the acaricide.

-Dipping animals in plugs dips containing the acaricide.

-Hand dressing using pyegrease.

ENDOPARASITES (INTERNAL PARASITES)

These are parasites which live within the body of the host animal e.g. tapeworms, Round worms, Fluke etc

Categories of Endoparasites

-Endoparasites are generally called helminthes

-They fall under 2 phyla

i)Platyhelminthes (Flat worms)

-class-trematoda (flukes)

-Cestoda (tapeworms)

ii) Nematelminthes (nematoda)- Round worms.

P L ATYHELMINTHES

-Are flatworms.

-Body is symmetrical

-Are hermaphroditic.

a) Tape worm (Taenia spp) -cestodes

-Have two main parts ie

-Has a head (Scolex) and a chain of segments called the strobila

-Each segment is called a proglottis.

-Scolex has suckers or hooks or both.

Animals affected – pigs

- Cattle

- Sheep.

- Goats.

- Donkey.

Symptoms of attack

-General emaciation

-Rough or staring coat.

- Scouring and sometimes constipation due to digestive disturbance.
- Pot-bellies especially in calves.
- Oedematous swelling under the jaw.
- Obstruction/blockage of the intestines when tape worms are present in large numbers.
- Ploglottides present in faeces.
- Anaemia.
- Excessive appetite.

N.B. Lifecycle of tape worm

- Tape worms attack farm animals as intermediate hosts and man as final host.
- There are two common species of tape worm
 - i) Beef tape worm (*Taenia saginata*)
 - ii) Pork tape worm (*Taenia solium*)
- Affected human beings drop Ploglottides full of eggs with faeces.
- Eggs are picked by the right intermediate host either cattle or pigs while feeding.
- After ingestion by the host (intermediate), Eggs hatch in the intestines into embryos.
- Embryos penetrate the intestinal wall and enter the blood system.
- They first move to the liver and then to all body muscles of the animal where they become cysts.
- Under cooked beef or pork from infected animals if eaten by man causes an infection.
- In the human intestine cysts wall dissolve and the parasites attach themselves to the wall of the intestine.
- Here they develop into adult tapeworms.

-These are passed out again in faeces.

Control measures and treatment

-Use of prophylactic drugs e.g. antihelminthes (dewormers) to kill parasites in animals.

-Keep animal houses clean and disinfected.

-Practice rotational grazing to starve the larvae (cysts) to death.

-Keep the feeding and watering equipment clean.

-Use of latrines by farm workers ie proper disposal of human faeces.

-Proper meat inspection.

-Proper cooking of meat.

b) Liver fluke (*Fascial* spp (Trematoda)

There are many species of flukes.

-Two are the most common ones ie

i) *Fasciola hepatica* (sheep)

ii) *Fasciola gigantica* (cattle)

-Heavy infestation of flukes cause a condition called Fascioliasis.

Symptoms

-Emaciation

-Indigestion in the animal.

-Pot bellied condition.

-Damage to liver tissue causing haemorrhage due to movement of flukes in the liver.

-Anaemia due to sucking of blood.

-Animals are dull and depressed.

-Swollen and painful abdomen.

-Recumbence precedes death.

N.B. *Fasciola* has the following characteristics

-Gray or gray-pink in colour

- Flattened like leaf.
- Have a conical projection at the anterior end.
- Have a tapering body ending.

Lifecycle:

- Liver fluke use the fresh water snail as their intermediate host.
 - They have sheep or cattle as their final host.
 - Adult flukes are found in the bile duct of the liver of the host animal.
 - Here they produce eggs which are passed into the alimentary canal through the bile duct.
 - Eggs are passed out through dung.
 - A fluke produces about 300-3500 eggs per day.
 - If the eggs fall into stagnant water that is warm, they hatch into a ciliated embryo called miracidia (miracidium)
 - On coming into contact with the intermediate host snail (*Limnea spp*). It penetrates the snail tissue.
 - Once inside the snail tissues, miracidium process masses of cells called sporocysts
 - Sporocysts change into Redia.
 - Redia produces cercaria more out of snail
 - Cercaria change into metacercaria which is the infective stage of the fluke
 - The definite/ final host through grazing or drinking infected water takes Metacercaria.
- N.B. Metacercaria can survive in wet grass and in shady places or when withstand harsh conditions for a year.
- Once swallowed by the host, cercaria penetrates walls of the intestine and hatch into adults.

-Adults migrate to the liver where they grow, mature, mate and produce eggs.

-The cycle starts all over again.

Control measures

1. Controlling the fresh water snail (intermediate host) through
 - a) Physically killing them.
 - b) Chemically by use of CuSO_4 Sodium pentachlorophenate etc which is added to stagnant water to kill the snails.
 - c) Draining swampy areas/leveling any depression that may hold water in the pastures.
2. Burning of the pastures during the dry seasons to kill cercaria
3. Not grazing animals near marshy or waterlogged areas.
4. Routine drenching using antihelminthes e.g. NaSO_4 , hexachloroethane drugs.

ROUNDWORMS (NEMATODES)

(*Ascaris* spp)

There are three common species of round worms

- i) *Ascaris lumbricoides* Cattle and sheep.
- ii) *A. suum* Pigs.
- iii) *A. galli* poultry.

-Heavy infestation of these worms cause a condition called *ascaridiosis*

Symptoms of Attack.

-Anorexia (Loss of appetite in heavy infestation)

-Staring coat (stiff and dry)

-Dehydration and pale mucosa

-Eggs and adults present in faeces.

-Emaciation

- Diarrhoea.
- Anaemia.
- Potbellies especially in young animals.

LIFECYCLE OF A ROUNDWORM

- The common roundworm *Ascaris lumbricoides* does not have intermediate hosts.
- Eggs are laid in the alimentary canal of the host animal.
- Eggs are passed out of the host with faeces.
- Under favorable environmental conditions, eggs hatch into larvae which climb

CROP PRODUCTION III (NURSERY PRACTICES)

Seedbed. This is a piece of land large or small, which has been, prepared to receive seeds at planting or seedlings at transplanting. The crop will establish and grow to maturity here.

Nursery bed. This is a special type of a seedbed prepared for raising seedling before transplanting. It should be 1m wide and of any convenient length.

Seedling bed. This is a special type of a nursery bed used for raising seedlings, which have been removed from the nursery bed due to overcrowding before they are ready for transplanting. This is called **pricking out**.

Importance of a Nursery in Crop Propagation

- a) It facilitates the planting of small seeds that develop into strong seedlings that are easily transplanted.

- b) Routine management practices are easily and timely carried out in the nursery than in the main seedbed.
- c) It is possible to provide the ideal conditions for growth such as watering, fine tilth and shade to the plants.
- d) It facilitates the production of many seedlings in a small area.
- e) Ensures planting of only the healthy and vigorous growing seedlings.
- f) Excess seedlings can be sold earning income to the farmer.
- g) Seedlings raised in the nursery bed take a shorter time to mature than ones established directly.
- h) It reduces labour on the care of seedlings since the area is small.

Site Selection

The following factors should be considered when selecting a nursery site.

- a) *Nearness to water source.* For easy watering.
- b) *Type of the soil.* Soil should be well-drained, deep and fertile preferably sandy loam.
- c) *Topography.* Should be sited on a gentle slope to prevent flooding and erosion through run-off.
- d) *Security.* Should be well protected from theft and destruction by animals.
- e) *Previous cropping.* Avoid siting it on an area where the same crop species had been planted to avoid build up of pests and diseases.
- f) *Well sheltered.* Windbreaks are necessary to prevent strong winds, which can uproot the seedlings and cause excessive evaporation.

Categories of Nurseries

- Vegetable crop nursery
- Tree nursery
- Vegetative propagation nurseries.

Vegetable crop nurseries

- Most vegetable crops have small seeds and are established through the nursery.
- A suitable nursery site is selected and marked out.
- Vegetation is cleared using slashers, pangas, mowers etc.
- Trash is removed and the site is dug or ploughed to remove all the perennial weeds.
- Various nursery beds are measured and divided leaving paths of 60cm in between the individual beds.
- In dry areas the nurseries are sunken in order to conserve moisture.
- Beds are harrowed to a fine tilth and Phosphatic fertilizer or well rotten manure is broadcasted.
- Leveling is done using garden rakes, which also removes trash.
- Shallow drills, 10-20cm apart are made and the seeds are drilled uniformly And then covered lightly with the soil.

Tree nurseries

- Selected site is prepared the same way as for the vegetables.
- Alternatively, the seeds are pre-germinated by soaking them in water for 24-48 hours. The seeds are then planted in polythene sleeves, which are half filled with soil. The sleeves facilitate transporting of the tree seedlings during transplanting. The polythene sleeves are arranged in rows under shade in the nursery site.

Vegetative propagation nurseries

These are used to raise some cuttings before they are transplanted to the main seedbed e.g. in tea. Correct rooting medium must be provided to facilitate rooting.

- A suitable site is elected, cleared and leveled.
- The nursery unit should measure 3.66m x 1.22m.
- Polythene sleeves measuring 7.5-10cm in diameter and 23-30cm long are filled with the rooting mixture.

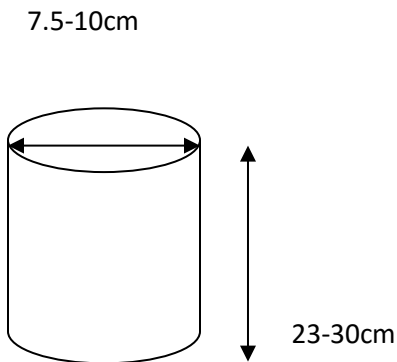

- The rooting mixture is made of the subsoil, double super phosphate and Sulphate of potash.
- 1m³ of subsoil is mixed with 450-600gm of DSP.
- The sleeves are then placed in the unit. Each unit holds about 1200 sleeves.

Preparing tea cuttings

Stem cutting are obtained from;

- High yielding mother plants.
 - High leaf quality plant
 - A plant with the ability to adapt to a wide range of ecological conditions.
- The selected mother plants are pruned and left to grow for six months unchecked.
 - The shoots that grow within this period provide cuttings, which are obtained from the middle part.
 - The brown hard bottom and the green soft part are discarded.
 - The bottom part takes long to root while the upper soft part tends to rot if planted.
 - A sharp knife is used to make slanting cuts above the axial bud.
 - The cutting should be 2.5-4.0 cm long. Each cutting should have a leaf.
 - The cuttings should be placed in water before they are planted to avoid dehydration.

- The sleeves are watered and then the cuttings inserted at the center of each sleeve.
- Leaf of the cutting should not touch the soil to avoid rotting. The sleeves should then be arranged in the vegetative propagation unit as shown below. Wooden hoops are erected over the sleeved cuttings and a polythene sheet is placed. The sleeves should be watered once every three weeks. Weeds appearing in the nursery unit should be uprooted.

Nursery management Practices

- i. Mulching.* This prevents excessive evaporation and moderates soil temperatures. It should however be removed on the fourth day or as soon as seedlings start emerging. Dry grass or straw from cereal crops can be used as mulch.
- ii. Watering.* Should be done regularly preferably morning and evening.
- iii. Weed control.* Weeds should be removed by uprooting.
- iv. Pricking out.* Where seedlings are overcrowded some should be removed and planted in a seedling bed. This reduces competition.
- v. Shading.* Should be provided but dark conditions should be avoided to avoid the seedlings becoming etiolated or pale.
- vi. Pest and disease control.* Appropriate chemicals should be applied to control pests and diseases. This should however start during the nursery bed preparation stage where the soil is sterilized through heat treatment or use of chemicals such as *furadan*.
- vii. Hardening off.* This the practice of preparing the seedlings to adapt to the ecological conditions found in the seedbed. This can be done through;
 - *Gradual reduction of shade 2-3 weeks before transplanting.*
 - *Reduction of watering.*
 - *Partial lifting of the seedlings in some cases.*

Grafting

This is the practice of uniting two separate woody stems. The part bearing the roots is called the **rootstock** while the part, which is grafted onto the rootstock, is known as the **scion**. Scion has buds, which develop into the future plant. The ability of the rootstock and the scion to form a successful union is referred to as **compatibility**. Only botanically closely related structures are compatible such as lemon and orange or lemon and tangerine.

Methods of Grafting

- *Whip or tongue grafting*. In this case the diameter of the rootstock and the scion are the same. It is carried out when the diameter of the scion and rootstock is pencil thick. A slanting cut is made with a sterilized sharp knife on both the scion and rootstock. They are joined together and wrapped with grafting tape or polythene strip.
- *Side grafting*. It is done where the stock has a larger diameter than the scion. The scion is inserted into the side of the stock.
Other methods of grafting include;
- *Approach grafting*.
- *Bark grafting*.
- *Notch grafting*.

Budding

This is the uniting of a vegetative bud (scion) to a seedling of another plant (rootstock). The scion has only one bud and some bark with or without wood. The bud is inserted in a slit made on the bark of the stock. It is held tightly on the stock by tying with budding tape until it produces roots.

Methods of Budding

- *T – budding.* A T-shaped incision is made onto the bark of the rootstock down to the wood. The incision is made 15-20cm above the ground using the budding knife. The bark is then raised and the bud is inserted by sliding it downwards under the lifted bark. The bud is then firmly tied. Materials such as adhesive tapes, rubber strips and polythene papers can be used for tying.

The wrapping is removed about two weeks after budding to inspect the buds. If they are green they have been accepted by the stock. The stock is then cut a few centimeters above the union. The green bud develops to produce a shoot. When the shoot reaches about 25cm it is tied to a stake to prevent it from being blown by wind and get broken. The piece of rootstock above the union is now cut 1-2cm above the union.

- *Top budding.* This involves budding of young trees where the buds are inserted at the desired locations. This allows the production of different varieties of fruits on the same rootstock as long as they are of the same species.
- *Patch budding.* The bark with a bud is removed from the scion stem and inserted into a patch where the bark has been removed from the rootstock. The union is tied on top and bottom tightly.

Importance of Grafting and Budding

- Plants with desirable root characteristics such as disease resistance, vigorous root system, and resistance to nematode attack but with undesirable products may be used to produce desirable products. E.g. orange lemon – graft.
- Grafting helps to repair damaged trees.
- They help to shorten the maturing age. Grafted mangoes take 3 ½ years to mature while non-grafted ones may take up to 7 years.

- They facilitate the changing of the top of the tree from being undesirable to desirable.
- They help to propagate clones that cannot be propagated in any other way.
- They make it possible to grow more than one type of fruit or flower on the same plant.

Layering

This is the process by which a part of system is induced to produce roots while still attached to the mother plant. Once the roots have developed the stem is cut off and planted.

Types of layering

- *Marcotting*. Commonly known as aerial layering. It is done on hardwood stems that cannot bend easily to reach the ground. Some moist rooting medium is heaped around a section of the branch whose bark and cambial layer has been removed. The rooting medium is wrapped with a polythene sheet to hold the soil and maintain it moist. *Auxins* (plant hormones) accumulate at the point where the bark has been removed thereby inducing root development.
- *Tip layering*. The shoot bearing the terminal bud is bent to the ground and then covered with a layer of moist soil. Pegs are used to hold it in position. After roots develop the shoot is cut off from the mother plant and transplanted.
- *Trench layering*. The branch of a stem is bent, laid in trench and is then held in position by pegs. The trench is then covered with moist soil. The buds develop shoots that grow upwards. Roots develop at the base of each shoot. The shoots are then cut off from the mother plant and transplanted.
- *Compound/serpentine layering*. The branch is bent several times and held in position by pegs. This produces several new rooted shoots from the same branch. However the branch must be highly flexible to achieve this.

Tissue culture for Crop Production

This is the generation of plants from plant tissues (cells). This is a biotechnology, which is used to clone vegetatively propagated materials. Tissue culture produces many propagules or explants. Cells are obtained from the tips and they are provided with certain conditions such as the culture medium, correct light intensity, temperature and relative humidity.

The following three stages are involved in tissue culture.

Stage 1

An aseptic culture is established. Cell division and enlargement is enhanced.

Disinfectants such as alcohol, calcium or sodium hypochlorite, mercury chloride and antibiotics are used to eliminate any contamination. All the tools used must be sterilized to establish a clean culture.

The culture medium should include inorganic materials, carbon and energy source (sugar), vitamins, organic supplements and growth regulators (hormones)

Stage 2

This involves a series of sub culturing to rapidly multiply the propagules through somatic development of embryos to produce auxiliary buds and adventitious roots. The culture medium should contain substances that enhance development of plant organs.

Stage 3

This involves the preparation of the propagules for the establishment in the soil. This includes the following.

- i) Rooting of the regenerated plantlets. This is promoted by supplementing the medium with auxins

- ii) Hardening the plantlets by inducing tolerance to moisture stress and attack by pathogens. Increasing the temperature and light intensity beyond those in the second stage can do this. Plantlets can also be exposed gradually to conditions similar to those in the field.
- iii) Converting the plantlets from *heterotropic* mode of nutrition to *autotropic* mode.

Importance of Tissue Culture in Crop Production

- i) It is used in the mass production of propagules.
- ii) Helps to establish pathogen free plants especially in the control of viral diseases.
- iii) It is fast and requires less space than the cultural methods of using cuttings, which require bigger space.

Disadvantages

- i) It is expensive, as it requires special structures.
- ii) Requires high skilled manpower.

Transplanting of Vegetable Crop Seedlings

- Seedlings are ready for transplanting when they are a month old or they have 4-6 true leaves or about 10-15cm.
- The nursery is watered 3-4 hours before lifting the seedlings. This ensures that seedlings are lifted easily with a ball of soil around the roots minimizing root damage.
- Healthy and vigorously growing seedlings are selected and lifted using a garden trowel.
- Transplanting is done when the weather is cool preferably in the morning or evening.
- The seedling is planted in the same depth it was in the nursery. The lower leaves should not touch the soil.
- Firming is done to ensure proper root-soil contact.
- Light mulch is applied and the seedlings are watered regularly.
- Shading is done where necessary.

Transplanting Tree Seedlings

- Holes for planting trees are dug long before transplanting day.
 - Topsoil is kept separate and is used for refilling the hole halfway.
 - Transplanting should be done at the onset of rains.
 - Seedlings should be well watered a day before transplanting. This makes the soil stick onto the roots. It also eases the removal of the polythene sleeves for seedlings raised in sleeves.
 - Seedlings are placed at the center of the hole.
 - A sharp knife is used to cut and remove the polythene sleeve.
 - More soil is added and firmed gently around the plant until the hole is completely full.
 - Seedlings should be planted at the same depth as they were in the nursery.
 - Watering should be done and mulch provided. A temporary shade may be established to conserve moisture.
-
- Young seedlings should be protected from damage by animals for about one year.
 - This can be done for individual trees or for an entire field.

CROP PRODUCTION IV (FIELD PRACTICES)

Field practices are operations carried out in the field to facilitate proper growth and optimum yield of the various crops grown. These operations should be timely for best crop performance.

Crop Rotation

This is the growing of different types of crops or crops of different families on the same piece of land in an orderly sequence. Land is subdivided into plots. Different crops are grown in each plot in a particular season. Crops are rotated in

the following season. This is applicable when dealing with annual crops.

Importance of Crop Rotation

1. *Maximum utilization of nutrients.* Different crops vary in terms of type of nutrient and depth of absorption. Maize absorbs a lot of nitrogen from the soil but low amount of potassium. Cassava needs a lot of potassium but little nitrogen. Therefore the two can be alternated for maximum nutrient utilization.

Deep-rooted crops absorb nutrients from deep layers of the soil as compared to the shallow rooted ones. The two should be alternated.

2. *Control of weeds.* Planting non-grass crops can help to control parasitic weeds such as witch weed (*striga weed*), which are specific to grass family crops.

3. *Control of soil borne pests and disease build up.* Some pests and diseases are crop specific. Alternating different crop families controls them.

4. *Soil fertility improvement.* When leguminous crops are included in a rotational programme, they fix nitrogen thus improving soil fertility.

5. *Soil structure improvement.* At the end of a rotation programme, a grass ley (piece of land planted with grass) is established. During this time there is little soil disturbance and roots bind the soil particles together improving the soil structure.

6. *Soil erosion control.* When cover crops such as sweet potatoes are included, they reduce soil erosion.

Factors Influencing Crop Rotation

The following factors should be considered when designing a crop rotation programme.

- i) *Crop root depth.* Deep-rooted crops should be alternated with shallow rooted crops.

- ii) *Soil structure.* A grass ley should be included in the rotation programme because the soil becomes loose after continued use.
- iii) *Pests and disease control.* Crops from the same family should not follow each other as the same pests and diseases attack them.
- iv) *Weed control.* Crops that are associated with certain weeds should be alternated with those that are not. Crops that are not easily weeded should be alternated with those that are easy to weed.
- v) *Crop nutrient requirement.* Heavy or gross feeders (crops requiring high amounts of nutrients) should come first in a newly opened land, which is relatively fertile.
- vi) *Soil fertility.* Leguminous crops should be included to improve soil fertility.

Rotational Programmes

The order and the sequence in which crops follow each other should be identified. This should be done in consideration of the above factors. If the farm is divided into four or eight fields, then a four-course rotation works very well.

Examples

- i) *Three course rotation.*
 First year- beans
 2nd year - maize
 3rd year - cassava
- ii) *Four course Rotation - a.*
 First year- yams
 2nd year - groundnuts or beans
 3rd year - maize or any cereal crop
 4th year - cassava or any root crop.
- iii) *Four course Rotation - b.*
 1st year - Irish potatoes.

- 2nd year - beans
3rd year - maize
4th year - sweet potatoes.

Terms Used in Crop Production

i) **Mono cropping.** This is growing one type of crop on the farm.

Disadvantages

- Plant uses only the nutrients it requires leading to their exhaustion while other nutrients are left unused.
- May lead to pest and disease build up if one crop is grown continually.

ii) **Inter cropping.** This is growing of two or more crops in the same field at the same time. E.g. maize and beans, beans and potatoes, bananas and coffee etc. This offers better soil coverage thus smothering weeds and also controlling soil erosion.

iii) **Mulching.** This is the placement of materials such as banana leaves or polythene sheets on the ground next to the growing crop. The materials should not come into contact with the base of the crop to discourage pest attack.

Importance/advantages of Mulching

- Soil water conservation by reducing evaporation rate.
- Smothers weeds hence suppressing their growth.
- Soil temperature moderation by acting as an insulator. This ensures no much variations in soil temperature both at night and day
- Reduction of runoff speed thus preventing soil erosion.
- Organic materials decompose to release nutrients thus improving soil fertility.
- Organic materials decompose to form humus, which improves soil structure and water holding capacity of the soil.

Disadvantages of Mulching

- It is a fire risk.
- Provides a breeding ground for pests that are harmful to crops.
- Traps light showers of rainfall lowering the chances of the raindrops from reaching soil.
- Expensive to acquire, transport and apply.

Types of Mulching Materials

- Organic materials. They include sawdust, wood shavings, coffee pulp, dry grass, banana leaves, dry maize stalks and any other appropriate vegetation.
 - Inorganic/synthetic materials. They can be black, yellow or transparent polythene sheets. They are expensive and therefore used only in the highly profitable crops such as flowers and pineapple production by Del Monte Kenya Limited in Thika.
- iv) **Mixed cropping.** This is the growing of two or more crops in the same field but in specific sections at the same time.*

Routine Field Practices

- i) **Thinning.** This is the removal or uprooting of excess seedlings to allow space for the remaining seedlings. Thinning should be done when the soil is wet to avoid destroying roots of the remaining seedlings. Thinning is done to obtain an optimum plant population in a given area.*
- ii) **Gapping.** This is the refilling or replacement of dead seedlings or empty spaces left by seeds that fail to germinate. This should be timely to avoid excessive shading of the newly planted seedlings. Gapping ensures optimum plant population.*

- iii) *Rouging*. This is the removal and destruction of the infected crops. This prevents the spread of the disease or pests. Rouging can control pests such as Maize stalk borers and bean fly. Rouging can also control *Armillaria root rot* in tea.
- iv) *Training*. This is the practice of manipulating plants to grow in a desired direction and shape. This can be achieved through,
- **Staking**. This is supporting plants having weak stems using strong sticks e.g. in tomatoes, garden peas and some bean varieties.
 - **Propping**. This is providing support to tall varieties of bananas and those with heavy bunches using forked (Y-shaped) stakes.
 - **Trellising**. This is providing support of crops with vines using wire or sisal strings. The strings are held by poles at definite spacing e.g. in passion fruits.
- v) *Earthing up*. This is the placement of soil in form of a heap around the base of the plant.

Reasons for earthing up

- In Irish and sweet potatoes to promote tuber formation.
 - In tobacco it improves drainage around the crop.
 - In maize it provides support hence preventing lodging.
 - In groundnuts it promotes production of the seeds.
- vi) *Pruning*. This is the removal of extra or unwanted parts of a plant. This could be due to overcrowding, breakage, pest and disease attack and unproductivity.

Reasons For Pruning

- *To train the crop to attain the required shape*. Formative pruning in tea is aimed to encourage lateral growth. Capping in coffee is done to encourage growth of suckers which are later allowed to develop as stems.

- *Control of cropping.* Most fruit crops do bear biennially, that is overbearing in one season which is caused by unproportional ratio of vegetative and productive parts. Removal of extra vegetative parts maintains correct ratio. This ensures uniform bearing in all the seasons.
- *To remove the diseased and unwanted plant parts.* This remove extra suckers, leaves, branches, flowers or stems.
- *To facilitate picking.* Tea and coffee bushes are pruned in order to maintain a low plucking table and bearing head respectively.
- *To ease spray penetration.* Pruning opens bush making spray penetration effective.
- *To control pests and diseases.* Pruning destroys the breeding grounds for pests and disease causing organisms. In coffee Antesia bug and CBD are controlled through pruning which opens up the bush to light.

Methods of Pruning

- *Pinching out.* This is the removal of the terminal buds. This is common in tomatoes where the terminal bud is pinched out. This practice is called capping in tea and coffee.
- *Annual pruning.* This is the removal of branches that have borne two crops and have undesirable growth characteristics. Dry, broken, too close or diseased branches are removed.
- *Coppicing or pollarding.* This is carried out in tree crops where branches are cut at specified points in order to achieve a desired shape.

NB/ Care must be taken during pruning. Cut surfaces may act as entry points to disease causing organisms. Cut surface must be protected by application of paint or Stockholm tar to seal the wound and keep off vectors such as aphids.

Tools Used in Pruning

- *Pruning saw.* For cutting hard branches and stems in coffee and citrus.
- *Pruning knife.* For cutting or pruning tea by use of strokes.
- *Pruning shears.* For trimming hedges.
- *Secateurs.* Used for cutting or pruning soft branches in coffee and citrus.

TEA

Plucking Table Formation in Tea

Young tea is encouraged to produce a lot of lateral branches which in turn form the frame to establish a wide plucking table.

Methods of frame formation

- Formative pruning method.
- Pegging method.

Formative Pruning Method

The plant is capped at different height to encourage lateral growth and discourage vertical growth. This method takes a long time to bring tea into bearing hence not commonly used.

Pegging Method

A young tea plant is allowed to grow for one year to attain a height of 25-30cm.

It is then cut back to 15cm above the ground. This encourages development of lateral branches.

These branches are left to grow to 60-75cm high.

They are forced to grow at an angle of 30° - 45° by use of pegs and the tips are nipped off. This stimulates the dormant buds to grow into shoots. The following ways can be used in pegging.

- *Use of individual pegs.* Each branch is held down by a single peg measuring about 50cm long. Many pegs are required and they are either metallic or wooden.

- *Use of rings of pegs.* A ring of 30cm diameter made out of thin sticks or a thick wire is used. It is placed on branches which are gently forced to bend to the sides of the bush at an angle of 30-45°. Three pegs are then placed to hold it in position. The tips of the shoots are nipped off to encourage the growth of more shoots.
- *Use of parallel sticks (fitos) pegs.* Two parallel straight light *fitos* are placed on either side of a row of tea bushes. Pegs are used to hold the *fitos* down. Light sticks about 45cm long are placed under the parallel sticks to hold in position any branches that lie between the *fitos*.

Tipping

This is the cutting back of shoots to the desired table height that is 20cm above the pegging height. This involves the removal of three leaves and a bud from each shoot above the required height of the table. The initial height should be 50cm above the ground level.

Two Y-shaped sticks 50cm in height and a long straight stick about 2 m long are used. The straight stick is placed on the Y-shaped sticks.

Tipping is done at 2-3 weeks intervals five times before the plucking table is properly formed. This process encourages formation of a uniform and a flat plucking table.

Maintenance of the Plucking Table

- Maintenance pruning helps to prevent rise in the plucking height. This is done by cutting back the tea bush to 5cm above the previous pruning height after 2-5 years.
- Three months after maintenance pruning, tipping is done just like in the plucking table formation.
- After many such pruning's, the tea bushes are cut down to 45cm above the ground. This is called *Rehabilitation (change of cycle)* and it is done after every 40-50 years.

Pruning Mature Tree

The following points are observed during pruning of tea.

- Side branches growing below the pruning height are not removed because this would reduce the spread of the bush reducing the yield.
- Outside edge of the bush should not be cut at a higher level than the centre to avoid a dish shaped frame.
- Bush should be pruned parallel to the slope using a measuring stick.
- Branches should be cut across in order to minimize the area of the wounds. Long slopping cuts increase die back and disease infection.
- Small branches and twigs on the frame are removed by hand.
- Branches should be placed on top of the frame to offer protection during the dry period. They should be removed at the start of the wet weather after the new shoots start to sprout.
- All the branches should be left to rot in the field as they contain a lot of nutrients and also act as mulch.
- Pruning knife must always be sharp to cut the branches and not to break them.
- After several pruning's, the tea is cut back to the original table. This is called change of cycle (rehabilitation).

COFFEE

Pruning in coffee is to regulate the quality and quantity of coffee berries.

Reasons for pruning in Coffee

- *Regulate bearing. Unpruned coffee tends to bear biennially i.e. it produces a heavy crop one season and a light one in the next season.*
- *To remove old and unproductive branches.*

- *To make harvesting easy by regulating the height of trees.*
- *To open up the bush to allow better air circulation. This removes the microclimate suitable for pest and disease organisms thus controlling them.*
- *Facilitate spray penetration.*
- *There is economic use of chemicals.*

Systems of Pruning in Coffee

- Single stem system.
- Multiple stem system

Single Stem Pruning

- In this case one permanent stem with a strong framework of primary branches is established. The main stem is capped at various heights as the bush grows.
- At each capping the best growing sucker is allowed to continue growing upwards. The first capping is done at 53cm, 2nd at 114cm and the final one at 168cm.
- The height of single stem bushes ranges from between 1.5-1.8m. In young trees, the initial crop is borne on the primary branches but as the bush matures, the crop is borne on secondary and tertiary branches successively.
- Annual pruning is done throughout the year but suckers are removed throughout the year.
- Single stem system allows easy picking and spraying and minimizes breakage of branches.
- It however requires skill in its establishment and takes time to bring bushes to bearing.

Multiple Stem Pruning

Two or three upright stem are maintained. There are two types of the multiple stem system i.e. capped multiple and non-capped multiple system

- In capped system, the main stem is capped at 38cm and 2-3 shoots are allowed to grow to a height of 1.5-1.8m.

The bushes are thereafter maintained as in single stem system.

- In non-capped system, the main stem is capped at 38cm above the ground. Suckers are then allowed to grow. Two to three suckers are selected and left to grow. When the stems get old after 4-6 years, they are removed. The removal of the old stems is called **changing of cycle**. Annual pruning involves the removal of lateral branches that have borne two crops, those that are too close, dry or broken and any that are undesirable. Suckers should be removed as they appear.

Advantages of non-capped multiple stem system

- Requires less skill to establish.
- Easy to prune.
- Doesn't allow accumulation of CBD due to frequent removal old stems.

Disadvantages

- Breaking of stems and branches.
- Difficulty in gathering the berries from the top points.
- Difficulty in spraying the tall bushes.
- Rotting of stumps with age.

Capping

- This is cutting the main stem at height of 53cm when the young coffee plant is 69cm tall. One lateral is selected and later capped at 114cm when it grows to 130cm.
- The third capping is done at 168cm when the lateral branch reaches 183cm in height. At each capping only one upright branch is selected and allowed to develop.
- Capping is mainly done in single stem system. The tree is kept capped at 1.5-1.8m.

De-suckering. This is the removal of suckers.

Changing the cycle. It's the replacement of old stem by suckers. This occurs after 4-6 years.

Cutting back in pyrethrum. This is the removal of the old stems down to the level of the top foliage at the end of the cropping year towards the end of the dry season. This increases production in the following season and minimizes incidences of *bud disease*.

Banana Stool Management. This involves the removal of extra suckers in the stool. 3-6 stem per stool are maintained. The suckers left should be at different stages of development; one sucker bearing, one half grown and the other one starting to grow. This ensures that they come into bearing at different times. Dry and diseased leaves should be removed using a sickle or *panga* to open up the stool.

vii) *Crop protection.* This involves the following;

- *Weed control.* Weeds are plants growing where they are not required. Potatoes growing in a wheat field are regarded as weeds. Some plants are however referred to as weeds regardless of where they are found such as black jack, couch grass, Sodom apple, wandering jew etc.
- *Crop pest control.* Pests are harmful to crops. They include insects, nematodes, rodents, thrips and mites. They reduce the quality and quantity of the crop products and should therefore be controlled.
- *Crop disease control.* A crop disease is any alteration in the state of a plant and functions of a plant or its parts.

Diseases are caused by;

- *Fungi.* CBD, maize rust, coffee rust, smut in maize and sorghum etc.
- *Bacteria.* Tomato wilt, cabbage black rot, black arm of cotton etc.

- *Virus*. Ratoon stunting disease of sugarcane, rosette disease in groundnuts, cassava mosaic.
 - *Nutritional cause*. Blossom end rot in tomatoes due to calcium deficiency.
 - *Physiological disorders*. Frost injury in tea, coffee etc.
- viii) *Harvesting*.

This is the final operation in crop production that is carried out in the field. Harvesting should be timely to avoid loss in quality and quantity of the produce.

Stage and Time of Harvesting

Time of Harvesting is determined by the following factors.

- *Market demand*. Consumers' preference is considered before harvesting. Maize is harvested either green or when the grains dry depending on market demand.
- *Concentration of the required chemicals*. In coffee the ripe berries are the ones harvested as they contain the required caffeine. In tea the two youngest leaves and the terminal bud are harvested as they give high quality tea.
- *Purpose/use of the crop*. Maize for silage making should be harvested just before flowering while that for grain production should be harvested when the grains mature.
- *Weather conditions*. Most crops should be harvested during the dry season to avoid losses. Synchronisation of planting and harvesting time should therefore be done
- *Prevailing market price and profit margins*. In some crops harvesting can be deliberately delayed to await better market prices. Carrots and pears can be harvested late to realize higher profit margins.

Methods of Harvesting

This depends on;

- Growth habit of the crop.
- Part being harvested.
- Scale of production.

Crop.	Method of Harvesting.
Coffee	Cherry red berries are picked and put in bags ready for pulping.
Tea	Two young leaves and terminal bud are plucked and put in airy baskets without compressing and then taken to factory immediately.
Irish potatoes	Sticks, <i>panga</i> , or <i>forked jembe</i> are used to lift the potato tubers when the stems have dried.
Beans.	Green pods are picked if the market demands for them. For dry beans the whole plant is uprooted after drying, spread on the mats to dry further, followed by threshing and winnowing.

Precautions During Harvesting

- Timing should be correct.
- Weather should be dry to avoid rotting of the produce.
- Delayed harvesting should be avoided as most crops get spoilt in the farm.
- Store should be ready to receive the produce after it is harvested.

Post Harvest Practices

They are carried out on the crop after harvesting. They include the following.

- Threshing/shelling.* This is the act of removing maize from the cobs, beans from the pods or sorghum from the heads. This is done to facilitate subsequent cleaning and storage. It is normally the first operation done after harvesting.

- ii.) *Drying.* Grains are dried up to a moisture content of 12-13%. This prevents rotting and fungal attack of the grains while in store.
- iii.) *Cleaning.* This is done by winnowing in cereals to remove the chaff from the grains.
- iv.) *Sorting and grading.* The produce is sorted and graded according to quality. In coffee the berries are sorted into grade I and II. Grade I has big and well ripened berries. Grade II berries are under-ripe, overripe, diseased or small. The first grade fetches the highest price.
- v.) *Dusting.* This is application of chemical powders on seeds to prevent storage pest attack.
- vi.) *Processing.* It is the transformation of the raw material into a final product. This is done in order to;
 - i.) *Improve the flavour of the produce as in tobacco and tea.*
 - ii.) *Improve the keeping quality as in fruits when canned or made into juices or sauces.*
 - iii.) *Reduce bulkiness to lower transportation and storage costs as in sugar cane when crushed into sugar.*

NB/ with vegetables such as kales and spinach, the leaves can be completely dried in the sun and stored in airtight containers for use during scarcity periods.
- vii.) *Packaging.* It is the placement of produce into containers for storage, sale or transportation. This reduces damage to the produce and also makes it possible for the farmer to quantify the produce and set prices.

STORAGE

Most agricultural produce are seasonal yet consumers need them throughout the year. Storage is therefore necessary to ensure availability of these products throughout the year.

Types of storage structures

- viii.) *Traditional storage structures.* Traditional granaries are elevated from the ground by posts. They are made of

wooden twigs woven together and roofed with thatching materials such as grass or reeds.

Disadvantages

- i.) Rats and weevils attack.
- ii.) Rotting of grains.
- iii.) Limited in size.

Others include pots and gourds for putting shelled grains.

ix.) *Modern storage structures.*

This is more improved than the traditional one. It should have the following properties/characteristics.

- i.) Vermin or rat proof.
- ii.) Well ventilated.
- iii.) Easy to load and offload.
- iv.) Pest free
- v.) Leak proof.
- vi.) Well Secured to minimize theft.
- vii.) Cool conditions to prevent overheating that would crack the grains.

Preparation of the store

- i.) *Cleaning the store.* Previous debris is removed as it may be harbouring storage pests.
- ii.) *Maintenance.* Broken, worn out part or leaking roof should be repaired.
- iii.) *Dusting.* Appropriate chemicals should be used to control pests.
- iv.) *Clearing vegetation around the store to keep off vermin around the store.*

LIVESTOCK HEALTH 1

(Introduction to Livestock Health)

Health. – State in which all the body organs or parts and systems are normal and functioning normally.

Disease - deviation or alteration in state of body of animal or its organs which interrupts the proper performance of its functions.

Importance of Keeping Animals Health

1. Healthy animals maintain high productivity.
2. So as animals to have a longer economic and productive life.
3. To produce good quality products which fetch high market value.
4. Healthy animals grow fast and reach maturity quickly.
5. So as not to spread diseases to animals and humans.
6. Healthy animals are economical and easy to keep as the farmer spends less money on their treatment.

Signs of Good Health in Livestock

They are grouped into the following categories.

- Physical appearance.
- Physiological body functions.
- Morphological conditions of the body.

Physical Appearance.

This can be examined in terms of the following.

- i. *Behaviour of the animal* – a healthy animal should not be over excited, aggressive or produce abnormal sound. It should be docile/gentle and produce normal sound.
- ii. *Movement of the animal* – healthy animal should have normal walking style/gait and should walk with ease.
- iii. *Posture* – healthy animal should have normal posture according to the species while standing or lying down.
- iv. *General appearance of the animal* – healthy animal should be alert, bright and responsive to touch.

Physiological Body Functions

This can be examined under the following;

- i. *Appetite and feeding.* Lack of or excessive appetite

- ii. *Defecation.* Dung containing eggs, larvae of parasites or blood stains indicates ill health. Healthy animals defecate normally and regularly.
- iii. *Urination.* Healthy animals should have normal and regular urination. Abnormal colour in urine such as red or heavy yellow indicates ill health.
- iv. *Body temperature.* Body temperature of a healthy animal should be within the normal range.
- v. *Respiratory rate.* Respiratory rate of a healthy animal should also be within the normal range. Illness. This is measured using the **Respirometer**. Difficult and fast breathing indicates illness.

Respiratory rate is influenced by the following factors;

- Body size of the animal.
 - Amount of exercise done by the animal.
 - Degree of excitement.
 - Ambient or environmental temperature.
- vi. *Pulse rate.* A healthy animal should have normal pulse rate. It varies from species to species and is also influenced by factors such as;
 - Degree of excitement.
 - Age of the animal.
 - Sex of the animal.
 - Physiological status of the animal e.g. in pregnancy.

Animal	Temperature (°C)	Pulse rate (Beats per Minute)	Respiratory rate (Breaths per Minute)
Cattle	38.5 – 39.5	50 - 70	10 – 30
Sheep	38.5 – 40.5	70 – 80	10 – 20
Goat	38.5 – 40.5	70 – 80	10 – 20

Chicken	40.4 – 43.0	200 – 400	15 – 30
Pig	38.0 – 39.0	60 – 80	8 – 18
Horse	37.5 – 38.5	28 – 40	8 – 16
Donkey	37.5 – 38.5	28 – 40	8 – 16

- vii. *Production level of the animals.* Loss of weight, emaciation and sudden drop in production may signify ill health.

Morphological conditions of the body

The morphological conditions may be observed in the following areas;

- i. *The visible mucous membranes.* In normal health, the mucous membranes should be pink in colour, moist, soft, smooth and well lubricated. In ill health they are bright red, pale, yellowish or bluish in colour.
- ii. *The skin and animals coat.* Healthy animals have smooth, soft, warm and moist skin especially around the muzzle. Dry and staring coat, loss of hair, swellings on skin etc are signs of ill health.

Predisposing Factors of Livestock Diseases

These are conditions inside or outside the body of an animal which lead to the animal contracting a disease or an injury.

They include the following;

- i. *Species of the animal.* Some diseases are confined to certain species e.g. Newcastle disease in poultry and swine fever in pigs.
- ii. *Breed of the animal.* Some diseases are confined to certain breeds such as Hereford suffer from cancer of the eye and solar erythema affects only the large white pig breeds.

- iii. *Age of the animal.* Some diseases are associated with certain age groups e.g. piglet's anaemia affects only piglets, lamb dysentery affect lambs and calf pneumonia affects calves.
- iv. *Sex of the animal.* Some diseases affect a particular sex e.g. mastitis affects lactating female animals, orchitis affects males as it affects the testis.
- v. *Colour of the animal.* Black animals suffer more to heat stress. Animals with light pigmentation may suffer from disorders such as photosensitization when exposed to high light intensity such as the large white breed of pigs.

CAUSES OF LIVESTOCK DISEASES

- (a) Nutritional cause
- (b) Physical causes
- (c) Chemical cause
- d) Living organisms

A) NUTRITIONAL CAUSES:

This may be due to:-

- a) Mineral imbalances
 - Mineral deficiency problems are more common in rapidly growing animals
 - The deficiency of certain minerals in the diet of livestock can cause the following nutritional disorders.
 - i. Anaemia in piglets due to lack of iron.
 - i. Curled toe paralysis in poultry due to lack of calcium and phosphorous.
 - ii. Milk fever (*parturient paresis*) in lactating dairy animals due to lack of calcium.
- iii. Development of goiter in young calves due to iodine deficiency.
- iv. *Enzootic ataxia* or swayback in lambs due to lack of copper.

- v. *Bovine ketosis* or acetonaemia due to impaired metabolism of carbohydrates and volatile fatty acids.
- vi. Osteomalacia due to lack of carbohydrates.

b) Amount of food eaten by an animal

-Excess intake of lush pasture will cause bloat or Ruminant tympany

- This is a digestive disorder of ruminating animals caused by production of Excess gas (Methane) in the rumen during fermentation.
- Excess food eaten especially in animals with single stomach (monogastrics) can cause rupture of the stomach, diarrhoea or constipation.
- Low food intake or lack of food results in loss of weight, poor health and in extreme cases result in starvation and even death.
- Animals that lack proteins, carbohydrates, minerals and vitamins become emaciated, unproductive and occasionally suffer from diseases.
- Feeding animals on contaminated feeds cause death e.g. rotting grains may contain aflatoxin, which is very poisonous.

B) PHYSICAL CAUSES

-These include physical injuries to the body organs or parts such as

-Sudden or violent physical force can result into fracture.

C) CHEMICAL CAUSES

- If an animal eats, swallows or inhales chemicals such as acids, insecticides, herbicides etc it can be poisoned.
- Poison is any substance, which interferes with the normal structure or the physical metabolism of an animal's body if it comes into contact with its internal body organs.
- Most chemicals cause irritation, corrosion and burning of tissues or interfere with body systems.

- Other chemicals may interfere with membrane permanently.
- Stings from certain insects in sensitive parts of the body can cause irritation to the animal and may also cause swelling.
- Some weeds in pasture are poisonous if eaten by animals e.g. *Datura stramonium* (Thorn apple)

D)LIVING ORGANISMS

- These are the most common cause of diseases in livestock.
- These disease-causing organisms can be divided further into two groups.
 - Infectious disease causing organism
 - Parasitic organisms.
- (i) Infectious disease causing organisms
 - These are microscopic organisms they include protozoa, bacteria and viruses.
 - These organisms invade the animal, multiply and produce toxins.
 - The causal organisms are classified into the following groups.
 - Bacteria
 - Bacteria reproduce and multiply very rapidly.
 - They are found in the air, food, water and soil.
 - Some bacteria are pathogenic and others are non-pathogenic hence beneficial eg a ruminant cannot digest cellulose without the help of bacteria.
 - Pathogenic bacteria are harmful and cause some of the most dangerous livestock diseases eg Anthrax.
 - Bacteria have different shapes i.e.
 - Cocci---spherical
 - Bacilli—cylindrical

Vibrios—comma

Spirilla—spiral

□ Viruses

- They are very small organisms than the bacteria. They have DNA&RNA in their coat.
- They can only grow and multiply in the living cells of the other organisms.
- Viruses invade the cell, grow, multiply and eventually kill the cell.
- They do not produce toxins like bacteria but reproduce rapidly leading to death of cells.
- Most viral diseases are very contagious and highly infectious.

□ Protozoa

- Are microscopic single celled organisms.
- Some protozoa's are pathogenic and parasitic in animals.
- They multiply fast in the host body.
- Arthropod vectors such as ticks, tse tse flies and mosquitoes spread them.
- They can produce toxic substances that are capable of causing disease.

PARASITIC ORGANISMS

- Parasitic organisms harm animals in that they suck blood, transmit other disease causing organisms, can block internal organs in the animal and also cause injuries to the body organs.

- Parasitic organisms are divided into
External –ticks, fleas, keds, tse tse flies.
Internal—Roundworms, tapeworms, fluke etc

GENERAL METHODS OF DISEASE CONTROL

They are generally grouped into 2

- i) Routine management practices
 - ii) Preventive measures
- i) Routine management practices

This includes

- (a) Proper feeding and Nutrition
 - Livestock should be given balanced rations or diets in adequate amounts.
 - Adequate amounts of vitamins should also be given to the animals.
 - Actively growing animals require huge amounts of proteins.
 - A well-balanced ration prevents nutritional and metabolic disorders.
 - It also promotes disease resistance in the animals.
- (b) Proper Breeding and selection
 - During breeding only healthy animals should be selected.
 - Such animals should be free from diseases and also resistance to diseases.
 - Proper breeding programs should be adopted to avoid disease transmission.
- c) Proper housing and hygiene
 - Animal houses should be constructed in such a way that they meet the necessary requirement of particular animals.
 - Proper housing controls diseases such as mastitis in dairy animals, calf scours etc

- Pests such as mites in poultry can be controlled through proper housing.
- proper hygiene should be observed in animal houses eg
 - ©At the entrance of animal houses, a footbath made of 2% CuSO_4 should be provided.
 - © Diseases like foot rot should be controlled by 5-10% CuSO_4 solution or 2-5% formalin solution.
- Proper disposal of carcasses in the farm should also be practiced.
- Animal structures should meet the following conditions.
 - Well ventilated and free from draught (cold and wind)
 - Have adequate space for the animals housed.
 - Have proper drainage.
 - Leak proof.
 - Well lit.
 - Easy to clean.

ii) Preventive measures. These include;

(a) Isolation of sick animals

-Any animals showing clinical symptoms of ill health should be isolated from the rest of the herd to avoid further spread.

-It's usually applied against highly infectious and contagious disease to prevent spread.

(b) Imposition of quarantine

Quarantine-- is restriction of movement of animals and their products from and into the affected areas in the event of an outbreak of a notifiable disease.

Notifiable disease — this is a disease whose outbreak must be reported to a government authority such as veterinary officer.

-During quarantine, affected animals are isolated and their movement is restricted to prevent the spread of the disease causing organisms to the healthy animals.

(c) prophylactic measures and treatment

Prophylactic measures—refer to the control of diseases and parasites using preventive drugs. Such measures include;

i) Use of prophylactic drugs

Eg- Coccidiostats in poultry to control coccidiosis

-Drenching animals using ant helminthes against internal worms in sheep, cows etc

-Use of sulpanomides to control trypanosomiasis.

-Use of antibiotics to control/prevent some diseases.

ii) Carrying out regular vaccination.

-Vaccines contain a dead or weakened disease causing organisms and are injected into the animals' blood stream.

-The animal then produces antibodies eg in the control of viral diseases such as Newcastle, Rinderpest, Rabbits and fowl pox.

-Bacterial diseases controlled by vaccination include anthrax fowl typhoid and black water.

iii) Control of vectors

-A vector is an organism that transmits a disease from an infected animal to a healthy one.eg ticks, tse tse flies, mites etc.

iii) Treatment of sick animals

-Sick animals should be treated to avoid the spread of the disease.

-Antibiotics are used to treat bacterial diseases.

-Viral diseases are however difficult to treat

(d) Slaughtering the affected animals.

Animals suffering from highly infectious and contagious diseases e.g. Rinderpest, foot and mouth, Newcastle etc should be isolated and slaughtered.

-this prevents any further spread of the disease.

(e) Use of antiseptics and disinfectants

-Antiseptics are preparations containing germ killing agents and antibacterial drugs. They are used on the skin or in wounds.

-Disinfectants are very concentrated germinal chemicals used to kill bacteria in buildings and in animal structures.

APPROPRIATE METHODS OF HANDLING LIVESTOCK

Livestock handling should be carried out in the most humane and technical way in order to avoid stress or injury to the animal.

Reasons for handling animals

1. When administering any form of treatment to the animal
2. When spraying or hand dressing the animal with chemicals to control external parasites.
3. When inspecting the animal in case of any signs of ill health.
4. When milking the animal.
5. When performing certain routine management practices eg dehorning, castration, hoof trimming, vaccination etc.

METHODS OF RESTRAINING THE ANIMAL

- ❖ Use of crush.
- ❖ Use of ropes.
- ❖ Use of bullring and lead stick.
- ❖ Use of head yoke

NB: In livestock health, the following activities call for handling of animals.

(a) Drenching

-This is the oral administration of drugs to the animal.

- The drug can be in solid or liquid form.
- A drenching gun is used to administer liquid drugs through the mouth.
- A bolus gun is for solid drugs.
 - The animal should be restrained in a crush and the head is held close to the stocks man under the left armpit.
 - The mouth is then opened with the left hand and the drugs pushed in with the drenching or bolus gun using the right hand.

(b) Injection

The drugs are injected into the muscles (intramuscularly) or into the veins (intra-veins)

- Care should be taken to select the correct site of injection.

(c) Mastitis control.

-When performing this operation, the animal is restrained in a crush.

- Complete milking is done after which antibiotics are infused into the teats.

(d) Hand spraying.

- The animal is restrained in a crush for this operation.
- A stir-up pump or a knap sack sprayer is used to spray the acaricide onto the animal.
- Proper attention should be given to all the sites preferred by ticks.

LIVESTOCK HEALTH II (PARASITES)

Parasite- A living organism that lives in or on another organism and obtains nourishment from that organism without being useful to it in any way.

- This host-parasite relationship is referred to as parasitism.

Effects of parasites on livestock

(i) Cause Anaemia

-Blood sucking parasites take large volumes of blood from the host animals leading to anaemia.

ii) Deprive the host of nutrients (food)

-Internal parasites compete for food with the host animals this result into loss of weight, emaciation and low production.

iii) Injury and damage to tissue and organs.

-Biting parasites break the skin of the animal exposing it to secondary infection.

-Some internal parasites such as round worms, live fluke etc damage organs and tissues.

-Tissue injury results into Hemorrhage.

iv) Disease transmission.

-Some parasites act as vectors of some diseases

-They spread disease from sick animals to healthy ones.

v) Cause irritation

-Some external parasites irritate the animals through their biting effects.

-This causes the animal to rub itself against solid objects destroying skin, fur or wool.

vi) Obstruction to internal organs

-Internal parasites may cause mechanical obstruction or blockage of the internal passages.

-This leads to mal-functioning of organs affected.

TYPES OF PARASITES

e. External parasites (ectoparasites)

f. Internal parasites (endoparasites)

a. External parasites

-Found on the outside of the host body.

-They may live on or under the skin.

- Most ectoparasites belong to the phylum arthropoda.
- There are two main classes of these parasites.

- iii) Class insecta.
- iv) Class arachnida

CLASS INSECTA

These consist of tse tse flies, keds, mosquitoes, flies, lice and fleas.

a). Tsetse fly (*Glossina* spp)

- This is a true insect undergoing complete metamorphosis i.e.
- Tsetse flies give birth to larvae after the eggs hatch inside the body of the mother.
- Larva forms the pupa, which later changes into an adult.
- Tsetse flies bites mainly during the day.

Harmful effects

- They transmit Trypanosomiasis caused by a protozoan called trypanosome
- Sucks out blood from the animal causing anaemia.
- Cause damage on the skins and hides of animals making wounds, which provide routes for secondary infection by pathogenic organisms.

Control

- Bush clearing to destroy their breeding places.
- Spraying their breeding places with insecticides.
- Use of fly traps with impregnated nets.
- Use of sterilizing agents eg radio isotopes on male flies and then releasing them.

b).Keds (*melophagus orinus*)

- Are sometimes referred to as sheep ticks.

-They are hairy and wingless bloodsucking flies.

Harmful effects

- Cause irritation in heavy infestation.
- Due to irritation, animal scratches itself thus damaging the wool.
- Retarded growth in lambs.
- Anaemia.

Control measures

- Shearing the infected sheep and hand spraying them with appropriate chemicals eg pyrethrum, malathium, dieldrin etc
- Routine sheep dipping.

c) Fleas

They are wingless but have strong legs adapted for leaping over long distances.

- They suck blood, as their mouthparts are adapted for penetrating the host's skin and sucking blood.
- They pass through the following stages during development, egg- larvae- pupa- adult.

Harmful effects

- Cause irritation leading to scratching.
- Stick fast in poultry causing wounds on the comb and wattles.
- They cause anaemia.

Control measures

- Animals sleeping places should be kept clean.
- Dusting animal hooks with appropriate insecticides.
- Covering the stick fast fleas with petroleum to suffocate them.

d) Lice

They are small wingless insects and can be divided into two groups.

- Biting lice (mallophaga)
- Sucking lice (anoplura)

Biting lice-diagram

- They are found on both the birds and mammals.
- They have chewing mouthparts.
- They complete their lifecycle between three to four weeks.

Sucking lice

- Have mouthparts reduced into styles for sucking blood.
- They are found only on mammals.

Harmful effects

- Cause irritation to the animal hence, the animal is seen to rub itself against fixed objects.
- Heavy infestations cause loss of health in animals.
 - Since animals under attack do not feed very well, there is emaciation.
- Loss of production in birds.
- Anaemia and restless especially in poultry.

Control measures

- Spraying or dusting animals with appropriate insecticides.
- Keeping animal houses clean.
- Perches in poultry houses should be applied with insecticides e.g. 40% nicotine sulphate solution.
- Dusting each bird with sodium fluoride for individual treatment.

CLASS ARACHNIDA

- This consists of the ticks, mites and spiders.
- Ticks and mites belong to the order Acarina.

- These do not undergo complete metamorphosis.
- They have two body parts i.e. cephalothorax and the abdomen.
- The adults have 4 pairs of legs.
- (a) Ticks.
- Ticks rank as the single most important ectoparasites of livestock.
- They cause injury and spread very dangerous diseases.
- There are over 50 different species of ticks known.

Harmful effects.

- Vectors of diseases e.g. ECF, Red water, Anaplasmosis.
- Suck blood-causing anaemia to the host.
- Cause wounds through their bites.
- Cause irritation to the animal.
- Their bites lower value of hides and skins.
- Some ticks produce toxins that may be harmful to the host.

THE LIFE CYCLE OF TICKS

- Ticks usually pass through four main stages in their cycle i.e.
 - Egg
 - Larva (six legs)
 - Nymph (Eight legs)
 - Adult (Eight legs)
- Different species of ticks need different number of hosts.
- There are therefore three categories of ticks i.e.
 - One host ticks.
 - Two host ticks.
 - Three host ticks.

ONE HOST TICKS

- These ticks require one host to complete their lifecycle.
- Eggs on the ground hatch into larvae.

- Larvae climb onto the host, suck blood, become engorged and moult into nymphs.
- Nymphs feed on the same host, become engorged and moult into adults.
- Adults feed on the same host, mate and the females drop off to the ground to lay eggs.

Examples of one-host ticks

- Blue tick (*Boophilus decoloratus*)
- The Texas Fever tick (*Boophilus annalatus*)
- The Cattle tick (*Boophilus microplus*)
- The Tropical Horse tick (*Dermacentor nitens*)

TWO HOST TICKS

- This tick requires two hosts to complete their lifecycle.
- The larvae and nymphs pass through their stages on the first host.
- Eggs on the ground hatch into larvae, which climb on to the first host.
- A larva attaches themselves to the host, feed on blood, become engorged and moult into nymphs.
- Nymphs feed on the same host become engorged and then drop to the ground to moult in adults.
- Adults find a new host on which to feed.
- They feed on the second host and mate.
- Females drop off to the ground to lay eggs.

Examples of two host ticks

- Red legged tick (*Rhipicephalus evertsi*)
- The Brown tick (*Amblyomma maculatum*)
- The African Bont-legged tick (*Hyalomma truncatum*)
- Large Bont-legged tick (*Hyalomma rufipes*)

THREE HOST TICKS

- These ticks require three different hosts to enable them to complete their lifecycle.
- Eggs hatch on the ground into larvae.
- Larvae attaches itself to the first host, feed on blood, become engorged and drop off to the ground and moults into nymphs.
- The nymphs look for a second host, feed on blood, become engorged and drop off to the ground and moult into adults.
- Adults seek for the third host, climb, feed become engorged and mate.
- Females drop off to the ground to lay eggs.

Lifecycle of a three-host tick

Examples:-

- Brown ear tick (*Rhipicephalus appendiculatus*)
- East African Bont tick (*Amblyomma variegatum*)
- Bont tick (*Amblyomma herbraeum*)
- Gulf Coast tick (*Amblyomma maculatum*)
- Yellow Dog tick (*Haemaphysalis leachii*)
- Fowl tick (*Haemaphysalis hoodi*)
- Brown Dog Tick (*Rhipicephalus sanguineus*)

TICK CONTROL MEASURES

- i) Natural/Biological method.
- ii) Mechanical method.
- iii) Chemical method.

1. Natural/ Biological method.

-This is the use of the tick's natural enemies, which predate on the ticks. E.g. using predators such as birds to control ticks.

N/B Only a small number of ticks is controlled using this method.

2. Mechanical method

i) *Burning the infected pastures.*

-Burning destroys eggs, larvae, nymphs and adults.

ii) *Interfering with the ticks environment*

This is achieved by:-

-Ploughing pasture land .the eggs are exposed to the sun heat or are deeply buried.

iii) *By top dressing pasture using lime or dressing using acaricides.*

iv) *Fencing off the pasture and farm.*

v) *Hand picking the ticks (deticking)*

vi) *Starving the ticks to death*

-This is achieved by practicing rotational grazing.

-It interrupts the lifecycle of the ticks.

3. Chemical control method.

This is done by application of acaricide.

Properties of an effective acaricide

-Has the ability to kill ticks.

-Be harmless to both human and livestock.

-Be stable.

-Should remain effective after having been fouled with dung, mud or hair.

Methods of acaricide application

-Spraying regularly with the acaricide.

-Dipping animals in plugs dips containing the acaricide.

-Hand dressing using pyegrease.

ENDOPARASITES (INTERNAL PARASITES)

These are parasites which live within the body of the host animal e.g. tapeworms, Round worms, Fluke etc
Categories of Endoparasites

-Endoparasites are generally called helminthes

-They fall under 2 phyla

i)Platyhelminthes (Flat worms)

-class-trematoda (flukes)

-Cestoda (tapeworms)

ii) Nematelminthes (nematoda)- Round worms.

PLATYHELMINTHES

-Are flatworms.

-Body is symmetrical

-Are hermaphroditic.

a) Tape worm (Taenia spp) -cestodes

-Have two main parts ie

-Has a head (Scolex) and a chain of segments called the strobila

-Each segment is called a proglottis.

-Scolex has suckers or hooks or both.

Animals affected – pigs

- Cattle

- Sheep.

- Goats.

- Donkey.

Symptoms of attack

-General emaciation

-Rough or staring coat.

-Scouring and sometimes constipation due to digestive disturbance.

- Pot-bellies especially in calves.

- Oedematous swelling under the jaw.
- Obstruction/blockage of the intestines when tapeworms are present in large numbers.
- Ploglottides present in faeces.
- Anaemia.
- Excessive appetite.

NB Lifecycle of tapeworm

- Tape worms attack farm animals as intermediate hosts and man as final host.
- There are two common species of tapeworm
 - iii) Beef tape worm (*Taenia saginata*)
 - iv) Pork tape worm (*Taenia solium*)
- Affected human beings drop Ploglottides full of eggs with faeces.
- Eggs are picked by the right intermediate host either cattle or pigs while feeding.
- After ingestion by the host (intermediate), Eggs hatch in the intestines into embryos.
- Embryos penetrate the intestinal wall and enter the blood system.
- They first move to the liver and then to all body muscles of the animal where they become cysts.
- Under cooked beef or pork from infected animals if eaten by man causes an infection.
- In the human intestine cysts wall dissolve and the parasites attach themselves to the wall of the intestine.
- Here they develop into adult tapeworms.
- These are passed out again in faeces.

Control measures and treatment

- Use of prophylactic drugs e.g. antihelminthes (dewormers) to kill parasites in animals.
- Keep animal houses clean and disinfected.
- Practice rotational grazing to starve the larvae (cysts) to death.
- Keep the feeding and watering equipment clean.
- Use of latrines by farm workers ie proper disposal of human faeces.
- Proper meet inspection.
- Proper cooking of meat.

b) Liver fluke (*Fasciola* spp (Trematoda)

There are many species of flukes.

-Two are the most common ones ie

iii) *Fasciola hepatica* (sheep)

iv) *Fasciola gigantica* (cattle)

-Heavy infestation of flukes causes a condition called Fascioliasis.

Symptoms

- -Emaciation
- -Indigestion in the animal.
- -Pot bellied condition.
- -Damage to liver tissue causing haemorrhage due to movement of flukes in the liver.
- -Anaemia due to sucking of blood.
- -Animals are dull and depressed.
- -Swollen and painful abdomen.
- -Recumbence precedes death.

NB *Fasciola* has the following characteristics

- Gray or gray-pink in colour
- Flattened like leaf.
- Have a conical projection at the anterior end.
- Have a tapering body ending.

Lifecycle:

- Liver fluke use the fresh water snail as their intermediate host.
 - They have sheep or cattle as their final host.
 - Adult flukes are found in the bile duct of the liver of the host animal.
 - Here they produce eggs, which are passed into the alimentary canal through the bile duct.
 - Eggs are passed out through dung.
 - A fluke produces about 300-3500 eggs per day.
 - If the eggs fall into stagnant water that is warm, they hatch into a ciliated embryo called miracidia (miracidium)
 - On coming into contact with the intermediate host snail (*Limnea spp*). It penetrates the snail tissue.
 - Once inside the snail tissues, miracidium process masses of cells called sporocysts
 - Sporocysts change into Redia.
 - Redia produces cercaria more out of snail
 - Cercaria change into metacercaria which is the infective stage of the fluke
 - The definite/ final host through grazing or drinking infected water takes Metacercaria.
- NB Metacercaria can survive in wet grass and in shady places or when withstand harsh conditions for a year.
- Once swallowed by the host, cercaria penetrates walls of the intestine and hatch into adults.
 - Adults migrate to the liver where they grow, mature, mate and produce eggs.
 - The cycle starts all over again.

Control measures

1. Controlling the fresh water snail (intermediate host) through
 - d) Physically killing them.
 - e) Chemically by use of CuSO_4 Sodium pentachlorophenate etc which is added to stagnant water to kill the snails.
 - f) Draining swampy areas/leveling any depression that may hold water in the pastures.
2. Burning of the pastures during the dry seasons to kill cercaria
3. Not grazing animals near marshy or waterlogged areas.
4. Routine drenching using antihelminthes e.g. NaSO_4 , hexachloroethane drugs.

ROUNDWORMS (NEMATODES)

(*Ascaris* spp)

There are three common species of round worms

- iv) *Ascaris lumbricoides* Cattle and sheep.
 - v) *A. suum* Pigs.
 - vi) *A. galli* poultry.
- Heavy infestation of these worms cause a condition called *ascaridiosis*

Symptoms of Attack

- Anorexia (Loss of appetite in heavy infestation)
- Staring coat (stiff and dry)
- Dehydration and pale mucosa
- Eggs and adults present in faeces.
- Emaciation
- Diarrhoea.
- Anaemia.
- Potbellies especially in young animals.

LIFECYCLE OF A ROUNDWORM

- The common roundworm *Ascaris lumbricoides* does not have intermediate hosts.
- Eggs are laid in the alimentary canal of the host animal.
- Eggs are passed out of the host with faeces.
- Under favorable environmental conditions, eggs hatch into larvae, which climb onto grass and are eaten by host animals.
- Once ingested eggs hatch into young worms called juveniles, which migrate to the liver and lungs. They move up the trachea where they are coughed and swallowed with sputum to the intestines. Here they mature, mate and lay eggs. Eggs are passed out in faeces.
- Some species such as hookworms penetrate the animal's skin directly.

Control Measures.

- Rotational grazing.
- Drenching using appropriate antihelminths.
- Proper use of latrines by farm workers.
- Hygiene in the herd such removal of infected dung.
- Taking care not to contaminate any feed and forage.

Principles of Controlling Endoparasites

Factors to Consider When Controlling Endoparasites.

- i.) *The flock and its environment.* Control measures should be directed at the whole group together with their pastures and housing.
- ii.) *Nutritional status of the animal.* Good nutritional status of the animals increases the resistance of the animals to internal parasite infection.
- iii.) *Pasture management and rotational grazing.* Pastures should be given a resting period after grazing.
- iv.) *Housing management.* There should be adequate spacing of the animal. Clean bedding should be provided and manure

should be removed frequently. Hygiene should be maintained on feeding and water troughs.

- v.) *Protection of the young.* Since young animals are more susceptible than adults to worm infestation, they should be dewormed regularly. They should also graze ahead of the old stock.
- vi.) *Prediction of an outbreak.* The life cycle of each parasite should be known to make their control possible.
- vii.) *Treatment.* The following rules should be observed;
 - *Parasites or causal agents should be identified correctly.*
 - *Best available drug should be used at the right dosage.*
 - *Treatment should be done when the parasite is most susceptible to the drug.*
 - *Ecological requirement of the parasite must be known.*

Methods of Drug Administration

1. Strategic Treatment.

- Administration is regularly at the same time each year. All animals are treated to reduce pasture contamination.

2. Tactical Treatment.

- When rainfall is irregular, rapid multiplication of worms may occur calling for an additional tactical treatment. This is done when climatic and nutritional conditions are abnormal.

SOIL FERTILITY II (INORGANIC FERTILIZERS) ESSENTIAL ELEMENTS

Plant nutrients occur in the soil in the form of soluble substances. The plants take these substances in different quantities depending on their roles in plant tissues.

Essential Elements

These are nutrients needed by plants for various uses. They are divided into two categories;

- **Macro-nutrients** – are also referred to as major nutrients and are needed in large quantities.
- **Micro-nutrients** – are also referred to as trace or minor nutrients. They are needed by plants in small quantities but must be present.

Macro-nutrients

They include carbon, hydrogen, oxygen, nitrogen, phosphorous, potassium, sulphur, calcium and magnesium.

N, P and K are referred to as *fertilizer elements*.

Ca, Mg and S are referred to as *liming elements*.

Role of macro-nutrients and their deficiency symptoms.

1. Nitrogen. (NO_3^- , NH_4^+)

Its sources are; artificial fertilizers, organic matter and atmospheric fixation by lightning and nitrogen fixing bacteria.

Role of nitrogen in plants

1. Chlorophyll formation making the plant succulent deep green in colour.
2. Encourages vegetative growth especially in crops where leaves are harvested e.g. kales, Cabbages and pasture grasses.
3. Protein formation and protoplasm of all living cells.
4. Regulates the availability of phosphorous and potassium in plants.
5. Increases the size of grain cereals and their protein content.

Deficiency symptoms

1. Chlorosis or yellowing of the leaves.
2. Production of anthocyanin pigment instead of chlorophyll in tomatoes causing purplish colour.

3. Stunted growth where plants become dwarfed with extremely short roots.
4. Premature leaf fall.
5. Premature ripening of fruits.
6. Production of light seeds.

Effects of excess nitrogen

1. Scorching of the leaves.
2. Delayed maturity.
3. Excessive succulence in stems hence fall/lodging.

Loss of nitrogen from the soil

1. Soil erosion
2. Leaching
3. Volatilization
4. Crop uptake
5. Used by microorganisms.

2. Phosphorous. (H_2PO_4 , P_2O_5)

It occurs in the soil either in organic or in inorganic forms. It is converted into phosphates by microorganisms, which can be absorbed by plants. Since phosphates are relatively soluble in water they are not easily leached.

Source

- Organic manures
- Commercial fertilizers
- Phosphate rocks

Role of Phosphorous

1. Root development and nodules formation
2. Influences cell division.
3. Strengthens plant stems preventing lodging.
4. Hastens maturity of the crop, flowering, and fruit and seed formation.
5. Plays an important role in metabolic processes such as respiration, protein, fat and carbohydrate formation

Deficiency symptoms

1. Stunted growth.
2. Delayed maturity.
3. Increased production of anthocyanin pigment hence purple colour.
4. Yield of grains, fruits and seed is lowered.

Effects of excess Phosphorous

It leads to unavailability of iron, which is converted, into insoluble compounds, which cannot be absorbed by plants.

Loss of phosphorous from the soil

- Soil erosion
- Leaching
- Crop removal
- Fixation by iron and aluminium oxide.

3. Potassium. (K^+ , K_2O)

Sources

- Crop residue and organic manures
- Commercial fertilizers
- Potassium bearing rocks e.g. mica and feldspar.

Role of potassium

1. Component of chlorophyll molecule.
2. Plays important role in carbohydrate formation and translocation.

Assists in the uptake of nitrates from the soil and balances the effect on phosphorous and nitrogen uptake by plants.

3. Neutralizes organic acids in plants.
4. Strengthens plant stalks increasing plant vigour and disease resistance.

Symptoms of potassium deficiency

1. Leaf curling
2. Chlorosis

3. Premature leaf fall
4. Stunted growth.
5. Leaves develop a burnt/scorched appearance on the margin.

Loss of potassium from the soil

- Crop removal
- Leaching
- Soil erosion
- Fixation in the soil.

4. Calcium (Ca⁺).

Sources

1. Crop residues and organic matter.
2. Commercial fertilizers.
3. Weathering of soil minerals.
4. Agricultural lime such as dolomite and limestone.

Role of Calcium in plants

1. Protein synthesis.
2. Corrects soil PH increasing soil Cation Exchange Capacity (CEC) making more nutrients such as phosphorous and potassium more available.
3. Improves the vigour and strength of straw.
4. Helps in grain and seed formation.
5. Improves the soil structure.
6. Promotes bacteria activity in the soil.

Deficiency symptoms

- Blossom end rot in tomatoes
- Stunted growth
- Dying back of plant tips.
- Young leaves remain closed.

Loss of calcium

- Crop removal
- Leaching
- Soil erosion.

5. Magnesium (Mg^{2+}).

Sources

- Crop residues and organic manures
- Commercial fertilizers
- Agricultural lime
- Weathering of soil minerals.

Role of magnesium

- Synthesis of oil in crops such as Soya beans and groundnuts.
- Forms part of the chlorophyll.
- Promotes the growth of soil bacteria and enhances the nitrogen fixation power of the legumes.
- Activates the production and transport of carbohydrates and proteins in the growing plant.

Deficiency symptoms

- Inter-venial Chlorosis of the leaves where the parts between the veins become yellow.
- Leaves turn purple then brown and eventually die.
- Leaves curve upwards along the margin.
- Stalks become weak and the plant develops long branched roots.

6. Sulphur (SO_4^{2-}).

Sources

- Commercial fertilizers.
- Soil minerals containing Sulphide such as gypsum and pyrites.
- Atmospheric sulphur from industries through rainwater.

Role of sulphur

- Formation of proteins and plant hormones.
- Formation and activation of certain Co-enzymes such as coenzyme A.

- Influences plant physiological processes such as protein synthesis, chlorophyll formation, carbohydrate metabolism and nitrogen fixation.

Deficiency symptoms

- Stunted growth
- Poor nodulation in legumes
- Leaf Chlorosis hence anthocyanin pigment production.
- Thin stems and delayed maturity.

Carbon, Oxygen and Hydrogen

They are derived from the atmosphere and soil water. The three are raw material for photosynthesis in the presence of sunlight and chlorophyll. Oxygen is also needed for respiration to produce energy.

Micro Nutrients

They are also referred to as trace or minor elements. They are required in small quantities but they are essential for proper growth and development of plants. They include iron, manganese, copper boron, molybdenum and chlorine.

Role of micronutrients and their deficiency symptoms

1. Copper, iron and molybdenum help enzymes that are involved in oxidation and reduction processes in plants.
2. Copper is involved in the utilization of iron and in respiration.
3. Iron is needed in the synthesis of proteins in the chloroplasts.
4. Molybdenum is necessary for nitrogen fixation to take place by the help of symbiotic and non-biotic bacteria. It is also necessary for the synthesis of amino acids and proteins in plants.
5. Boron is involved in the translocation of sugars in plants and in the absorption of water.

6. Zinc is involved in the formation of some growth hormones and is also involved in the reproduction process of some plants.

Inorganic Fertilizers.

These are artificially processed compounds, which are added to the soil to improve its fertility.

A. Classification of inorganic fertilizers

They are classified according to;

- *Nutrients contained.*
 - Straight containing only one macro-nutrient
 - Compound containing more than one macro-nutrient.
- *Mode of application.*
- *Time of application.*
 - Soil applied when planting
 - Top dressing after crop emergence
- *Effects on the soil pH.*
 - Acidic
 - Neutral
 - Basic.

i) Straight fertilizer

They contain only one macro-nutrient which could be N, P or K. they are named according to the element contained.

- *Nitrogenous fertilizers.* They contain nitrogen as the primary macronutrient. They include Calcium Ammonium Nitrate (CAN), Ammonium Sulphate Nitrate (ASN) Sulphate of Ammonia (SA) and Urea.
- *Phosphatic fertilizers.* Contain phosphorous. They include Single Super Phosphate (SSP), DSP, and TSP.
- *Potassic fertilizers.* Contain potassium. They include Potassium Chloride or Murate of Potash (KCl) and Potassium Sulphate or Sulphate of Potash (K_2SO_4)

ii) Compound or Mixed or Complex fertilizers

They contain two or more primary macronutrients.

If it contains two of the primary macronutrients it is referred to as an incomplete compound fertilizer. Examples DAP (18:46:0) 20-20-0 etc.

If it contains the three (N<P<K) it is referred to as a complete compound fertilizer. Examples are 20-10-10, 25-5-5+5s, 17-17-17 and 15-15-15.

B. Properties and Identification of Fertilizers

i) Nitrogenous Fertilizers

They have the following properties.

- Highly soluble in water.
- Most are highly corrosive and therefore should not be handled with bare hands. They also corrode metal surfaces such as iron and tin.
- Are highly volatile. Under hot conditions they change into gaseous form and escape into the atmosphere. They should therefore be applied to moist soils to avoid volatilization.
- They are hygroscopic and therefore absorb water from the atmosphere causing the granules to stick together or cake. They should therefore be stored under dry conditions.
- They are easily leached and should therefore be applied to already established crops.
- They have a scorching effect and should therefore not be brought into contact with any part of the plant.
- They have a short residual effect and should therefore be applied frequently.

Properties of Individual Nitrogenous Fertilizers

- *Sulphate of Ammonia* $(NH_4)_2SO_4$. Physical appearance, white crystals, has acidic effect, contains 20-21% N. its highly volatile and slow acting.
- *Ammonium Sulphate Nitrate (ASN)* $NH_4NO_3+(NH_4)_2SO_4$. Its less acidic, granules appear yellow orange or brownish in colour, contains 26% N. its both quick and slow acting and highly corrosive.
- *Calcium Ammonium Nitrate (CAN)* $NH_4NO_3+CaCO_3$. It's neutral in nature and highly hygroscopic. It has grayish granules and not corrosive. It contains 21% N.
- *Urea* $CO(NH_2)_2$. Has 45-46% N. occurs as small whitish granules. It is easily leached or volatilized. It is rarely used except in crops with a high absorption capacity such as sugarcane.

ii) Phosphatic Fertilizers

They have the following properties.

- Has low solubility and immobile. However they may combine with ions of aluminium fixing phosphorous into unavailable forms to the plants. They should therefore be place next to the roots so that plants can utilize them before phosphorous becomes fixed.
- Have a slight scorching effect and should be mixed thoroughly with the soil to minimize the scorching effect.
- Are not easily leached and therefore are applied during planting time.
- They have a residual effect and hence benefit subsequent crops.
- They are not very hygroscopic and therefore easy to store.

Properties of Individual Phosphatic Fertilizers

- *Single Super Phosphate (SSP)*. It has 20-21% Phosphorous penta-oxide (P_2O_5). Induces negligible acidity and its water-soluble. It's in the form of white creamy granules.

- *Double and Triple Super Phosphate (DSP and TSP)*. They contain 43-52% P_2O_5 and occur in form of grayish granules smaller than those of CAN. It induces negligible acidity in the soil.

iii) Potassic Fertilizers

Characteristics

- Moderate scorching effect
- More soluble in water than Phosphatic ones but less than nitrogenous ones. Most East African soils have adequate potassium and should therefore be applied only where soil test show its deficient.

Properties of Individual Potassic Fertilizers

- *Potassium Chloride (KCL)*. It is also referred to as Muriate of potash. It contains 50% K_2O . It induces negligible acidity to the soil. It is hygroscopic. It occurs in the form of creamish or light coloured granules.
- *Potassium Sulphate (K_2SO_4)*. It has 50% K_2O . Reacting Muriate of potash with sulphuric acid makes it. It induces negligible acidity to the soil. It is also referred to as Sulphate of potash.

iv) Compound or Mixed Fertilizers

-Are made by mixing two or more straight fertilizers. Their nutrient content is expressed in two ways.

- *Fertilizer grade*. This indicates the guarantee of minimum content as a % of $N:P_2O_5:K_2O$ in the fertilizer for example 10-20-0, 17-17-17 etc.
- *Fertilizer ratio*. This is the relative % expressed as a ratio of the NPK present. For example, 10-20-0 will be 1:2:1 and 17:17:17 will be 1:1:1.

Properties of Individual Compound Fertilizers

- *Diammonium Phosphate (DAP) ($(NH_4)_2PO_4$ – 18; 46;0)*. It is moderately acidic because of the ammonium content. It is

applied at planting time and contains both phosphorus and nitrogen.

- *Nitrophos* – 20;20;0. Moderately acidic and contains both N and P.
- *Monoammonium Phosphate (MAP)* – 11;48;0. Its moderately acidic and has same properties as DAP.
- *Others* 23;23;0, 17;17;17, 20;10;10 and 25-5-5+5S

Fertilizer Application

- Phosphatic fertilizers are applied during planting time while nitrogenous ones are applied after crop emergence.
- In maize nitrogenous fertilizers are applied when the crop is 45-60cm or knee high. This application of fertilizers after the emergence of crops is referred to as top dressing.

Methods of fertilizer application

1. *Broadcasting*. This is the random scattering of fertilizers on the ground for plant use. This is applicable with the Potassic and nitrogenous fertilizers. Broadcasting should be done when the soil is moist. This is done manually or by the use of broadcasting machines. Shallow cultivation should be done after broadcasting to prevent loss through volatilization.
2. *Placement method*. This is the application of the fertilizer in the planting holes or drills. The fertilizer should be thoroughly mixed with the soil before placing the seeds. This method is recommended when applying Phosphatic fertilizers.
3. *Side Dressing*. This is the placement of nitrogenous fertilizer at the side of the crop being top-dressed. Side dressing can be done in two ways;
 - *Band application*. Placement of fertilizer along a band in between the rows of growing crops.
 - *Ring application*. This is the placement of fertilizer around the individual crop just beneath the edge of the canopy.

4. *Drip*. The fertilizer is dissolved and applied to individual plants through perforated pipes or bottles. This is common in horticultural crop fields and flower farms.
5. *Foliar spraying*. This is the application of specially formulated fertilizer solutions onto the foliage of the crop. The leaves directly absorb the fertilizer. This method is recommended when the conditions don't allow the use of the soil applied fertilizers e.g. during the dry season or when top-dressing very closely spaced crops such as wheat.

Determination of Fertilizer Rates

The amount of fertilizer applied in the field is determined by the amount of plant nutrients available.

Calculations Involving Fertiliser Application

- *Fertiliser grade or Analysis*. This indicates the amount of each nutrient contained in a fertiliser. It is calculated by determining chemically the % of each nutrient present in a fertiliser. That is,

$$\% \text{ Nutrient} = \frac{\text{Nutrient Content} \times 100}{\text{Total weight of fertiliser}}$$

This is usually calculated in terms of the amount of the three primary macronutrient NPK. Usually it is indicated on the bag of the fertiliser.

A bag of 100kg of a fertiliser of a 10-10-10 grade contains 10kg of N, 10kg of P₂O₅ and 10kg of K₂O. This shows that only 30kgs are active, the remaining 70kg is made up of filler material or carrier.

Fertiliser grade helps to determine the amount of fertiliser required per hectare and therefore the amount of fertiliser that one should buy.

- *Fertiliser ratio*. This refers to the relative proportions of the three primary macronutrients (NPK) in a fertiliser.
- *The amount of fertiliser or nutrient required per unit area (per hectare)*. The amount of fertiliser to apply per hectares

depends on the amount of nutrient needed and the fertiliser grade available.

The Carbon Cycle

This is the series of changes which carbon undergoes in the atmosphere, water, and soil and in living organisms. Carbon is an essential constituent of all living things. Carbon occurs in the atmosphere as carbon dioxide and constitutes 0.03% of air by volume.

Ways in which carbon is removed from the atmosphere

1. Photosynthesis. Green plants use CO₂ from the atmosphere during photosynthesis.

Carbon Dioxide + water ----- Glucose + Oxygen
The glucose formed is used by plants to provide energy and the excess is stored in storage structures such as grains and tubers.

2. *As rainwater passes through the atmosphere, it reacts with carbon dioxide to form weak carbonic acid. This reduces the amount of CO₂ in the atmosphere.*

Ways in which Carbon is returned to the Atmosphere

1. Decomposition. Once living organisms die, they decay releasing CO₂ into the atmosphere.

2. Respiration. During aerobic respiration oxygen is used to oxidize carbohydrates releasing energy, carbon dioxide and water. The Carbon dioxide is released to the atmosphere.

*Glucose + Oxygen ----- Energy+carbon +water
Dioxide*

3. Combustion. When carbon-containing materials such as wood and petroleum burn, carbon dioxide is released into the atmosphere.

Importance of the carbon Cycle

- Maintains the volume of carbon dioxide in the atmosphere.
- Ensures constant supply of CO₂ for plant use.

- Ensures a balance between CO₂ and O₂ to prevent the buildup of CO₂ to toxic levels.

The Nitrogen Cycle

These are the series of changes which nitrogen undergoes between the atmosphere, water, soil and living organisms. Nitrogen gas makes up to 78% of atmospheric air by volume; however it is not available to plants in this free gas form.

Ways in which Nitrogen is removed from the atmosphere

1. *Nitrogen fixation by lightning.* Atmospheric nitrogen combines with oxygen to form nitric oxide during lightning. Nitric oxide is easily oxidized to form nitrogen dioxide as shown below.

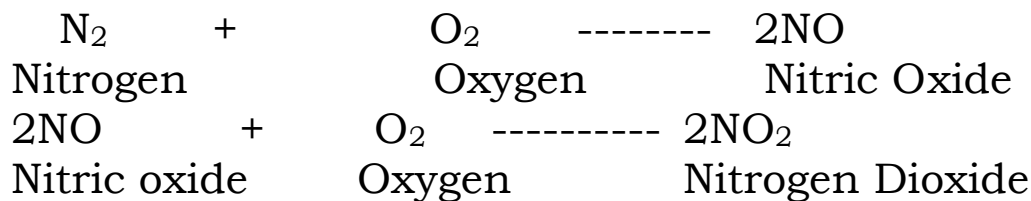

The nitrogen dioxide formed dissolves in water to form two acids, nitrous acid and nitric acid.

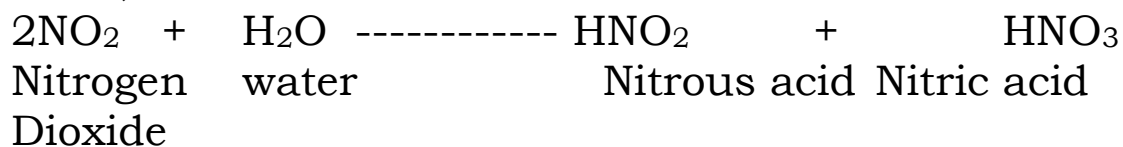

Nitrous acid is a weak acid and is quickly oxidized to form nitric acid.

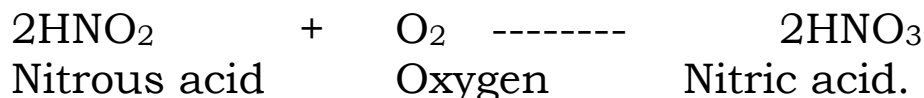

In the soil nitric acid is ionized to form nitrate ions (NO₃), which is now available to the plants.

2. *Nitrogen fixation by Nitrogen Fixing Bacteria.* This is divided into symbiotic and non-symbiotic nitrogen fixation.

- *Symbiotic fixation is carried out by Rhizobium bacteria found in the root nodules of legumes such as beans, peas, Lucerne, groundnuts etc.*
- *Free-living bacteria found in the soil carry out non-symbiotic nitrogen fixation. These bacteria convert atmospheric nitrogen into nitrates into the soil. Azotobacter and clostridium are good examples.*

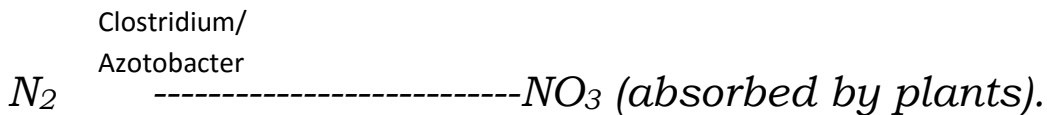

3. *Nitrification.* This is the process by which ammonium compounds are converted into nitrites and nitrates by the action of *Nitrobacter* and *Nitrosomonas* bacteria.
4. *The Harber-Bosch Process.* This results in the formation of ammonia.

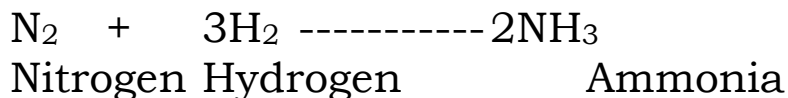

The ammonia produced is reacted with sulphuric acid or nitric acid to produce Sulphate of ammonia and ammonium nitrate fertilizers respectively. Ammonium nitrate can then be mixed with calcium carbonate to produce CAN.

Ways in which Nitrogen is returned to the Atmosphere

1. *Denitrification.* This is the conversion of nitrate ions (NO_3^-) to nitrogen gas (N_2) and ammonium ions (NH_4^-) into ammonia gas (NH_3), which escapes into the atmosphere. This is common in waterlogged soils and in very compacted soils. Denitrifying bacteria does this.
2. *Combustion.* Burning vegetation causes the conversion of nitrogenous compounds into nitrogen dioxide and ammonia, which escapes into the atmosphere.
3. *Volatilisation.* Sometimes ammonium compounds in the soil sublime to form ammonia gas, which escapes to the atmosphere.

Importance of the Nitrogen cycle

- Ensures the availability of nitrogenous compounds in the soil for plant use.
- Ensures the survival of the anaerobic microorganisms such as *clostridium*, which use nitrogen gas.

Soil sampling

This refers to obtaining a small quantity of soil that is representative in all aspects of the entire farm.

Soil sampling methods

- Traverse method. Four corners of the field are identified and sampling is done diagonally.
- Zigzag method. Locations are arranged in such a way that they are in a zigzag form

Soil sampling Procedure

- Clear the vegetation over the site.
- Dig out the soil at depths of 15-25cm for crop-land and 5cm for pasture land.
- Place the dug out soil in clean container.
- Repeat the above steps in different parts of the field, preferably 15-20 spots.
- Mix thoroughly soil from all the spots. The soil is crushed and dried.
- Take a sub-sample (composite sample) from the mixture and send to National Agricultural Laboratory for analysis.

The composite sample should have the following details before being taken to the laboratory;

- Name and address of the farmer.
- Field number
- Date of sampling.

Sites to avoid during the sampling

- Dead furrows and ditches
- Near manure heaps
- Swamps
- Recently fertilized soils

- Ant hills
- Under big trees
- Near fence lines or footpaths
- Between slopes and bottom-land.

Soil Testing

This is the analyzing of the soil samples to determine the ability of the soil to supply the essential elements.

Importance of soil testing

- To determine the value of the soil hence determine the crop to grow.
- To determine the nutrient content hence find out the type of fertiliser to apply.
- To determine whether it is necessary to modify the soil pH for a crop.

Soil pH (potential hydrogen)

- This refers to hydrogen ion (H^+) concentration in the soil. It is also referred to as the soil reaction. Soil pH measures the acidity or alkalinity of the soil solution. Soil acidity is caused by the H^+ ions while soil alkalinity is caused by the hydroxyl ions (OH^-).
- The pH scale ranges from 1-14 with 7 being neutral; pH below 7 is acidic and pH above 7 is termed as basic or alkaline. These numbers are negative logarithms or powers. For example at pH 5 the amount of H^+ concentration is 10^{-5} .
- Most nutrients are available at neutral pH e.g. phosphates are available at pH 6.5-7.5.
- Low soil pH lowers the availability of phosphorous as phosphates become fixed by iron and aluminium. Molybdenum is also unavailable at low pH.
- Too high pH makes manganese, potassium, boron, iron and zinc less available.

Testing Soil pH

- Use of the pH meter.
- Use of colour indicator dyes.

Importance of Soil pH to Crops

1. Determines the type of crop to be grown in an area. For example, tea prefers acidic soils while barley is affected by low pH.
2. Influences the incidences of soil borne pests. E.g. Pests such as nematodes are more serious in acidic soils than in neutral soils.
3. It determines the availability or absence of nutrients.
4. Influences the activity of soil microorganisms. E.g. low soil pH favours fungi and discourages bacteria. Therefore bacterial diseases such as potato scab caused by *Aceptomyces scabies* are common in high pH soils while fungal diseases such as club root caused by *Plasmodiaphora brassicae* are common in low pH soils.
5. Influences the physical and chemical characteristics of the soil.

REVISION QUESTIONS

1. a) Describe the production of tomatoes under the following sub headings.
 - i) Ecological requirements (3mks)
 - ii) Nursery establishment (4mks)
 - iii) Planting (3mks)
 - iv) Pest control (3mks)
 - v) Disease control (3mks)
 - vi) Marketing. 4 mks
2. Mention **four** categories of vegetables based on the part used as food. (4mks)
3. a) Describe the field production of Onions (**Aleum Cepa**) under the following sub topics;
 - i) Ecological requirements (3mks)

- ii) Varieties (2mks)
 - iii) planting (4mks)
 - iv) Field management practices (4mks)
 - v) Harvesting (4mks)
 - b) Name **Three** diseases of cabbages (3mks)
- 4** Name any 4 management practices done in carrot production. (4 mks)
5. Describe the establishment of cabbage seedlings under the following sub-heading:-
- (a) Establishment of the nursery (7mks)
 - (b) Management of seedlings in the nursery (6mks)
 - (c) Transplanting of seedlings (7mks)
6. Give **four** reasons for staking tomatoes (4mks)
7. Give 4 effects of excess nitrogen in tomatoes. (4 mks)
8. State 3 causes of blossom end rot in tomatoes. (3 mks)
9. Give 4 reasons for staking in tomatoes. (4 mks)
- 10 Name 3 fresh market and 3 processing tomato varieties. (3 mks)
- 11 Name the early maturing cabbage varieties. (3mks)
12. Why is it not advisable to apply manure in carrot production? (1 mk)
13. Name the two main categories of carrots and give an example in each case. (2 mks)

MARKING SCHEMES

- 1. a) Production of tomatoes
 - i) Ecological requirements

-Warm climate with a temp ranging (15 – 25°C), 20°C- 25°C during day and 15°C – 17°C at night. Altitude 0 – 2100m above sea level- Soil should be deep- Well drained- PH 5 – 7.5- Rainfall 760 – 1300 mm/ year / p.a- Well distributed throughout the growing period **($\frac{1}{2}$ mk for each correct answer $\frac{1}{2} \times 6 = 3$ mks)**

ii) Nursery establishment and management.

- The nursery should be sited on a gently sloping land.
- A nursery of width 1m is prepared and soil raised to 15cm.
- The bed should be prepared to a fine tilth
- Planting furrows or drills are made at 10 – 15cm apart using a stick of pencil thickness.
- Seeds are planted thinly along the furrows and covered lightly with the soil and firmed.
- A light mulch cover is placed on the bed and watering done.

(1mk each for any 4 points)

iii) **Planting**

- Planted at well prepared seedbed with deep soils free from weeds
- Spacing 60cm x 60cm (single row) or 60cm x 60cm x 90 cm (double row planting)
- 200kg of DAP per hectare is used for planting
- 10 tons of farm yard/ compost manure per hectare
- Nematocide should be applied on planting time to control nematodes.
- Seedlings should be watered before transplanting
- Transplant in the evening or during a cloudy day
- Mulch the seedlings after transplanting ($\frac{1}{2}$ mk for any 6 correct points)

iv) **Pest control.**

-cut worm

American bollworm (1mk)

-The adult moth lay eggs on young tomato fruits

-When they hatch the larvae bore into the fruits and feed on them

Control

-Routine spraying of tomatoes with recommended pesticide eg. Karate, Ambush

Nematodes (1mk)

-Can be controlled by crop rotation

-Fumigation of the soil using furadan

v) **Disease control**

i) Bacterial wilt (1mk for mention)

Control

- Crop rotation

-Uprooting and burning the affected plants **(1mk each for any 2 correct points)**

-Blossom end rot . **(1mk for mention of any one disease)**

Cause

-Too much Nitrogen in the early stages of growth

- Irregular watering

- Calcium deficiency

Control

- Regular watering

- Apply sufficient amount of calcium (add CAN)

- Top dressing with the right amount of

Nitrogen**(1mk each for any 2)**

e) **Marketing**

- Sort and grade them- Pack in wooden boxes- Sold to consumers directly- Sold to green grocers - Sold to

canning factories- Fresh market tomatoes should have a reddish colour- For canning should be left to ripen

2. Categories of vegetables based on the part used as food.

- Leaf vegetables- Root vegetables - Stem vegetables-

Pod vegetables- Flower vegetables- Fruit vegetables

3. a) i) Altitude – 2,100m above the sea level ✓

Rainfall – 1,000mm per year ✓

- fairly long period for ripening ✓

- irrigated during dry spell ✓

Soil – fertile and well drained ✓ - Ph – 6.0 – 7.0

✓

(3mks)

ii) Varieties – red creole ✓

- Tropicana hybrid ✓

- White creole ✓

(2mks)

iii) Planting – Can be sown directly or started off in a nursery bed. ✓

- 250kg Dsp used during planting ✓

- Rows for direct planting should be 30cm apart. ✓

- Seeds drilled and covered with light soil or transplanted at 8cm apart within the row. ✓

- Deep planting should be avoided as it inhibits bulb expansion. ✓

(1x4=4mks)

iv) - Thinning

- Weeding ✓

- Top dressing ✓

- Pest and disease control ✓

(1x4=4mks)

v) Harvesting ✓

- ready for harvesting after 5 months from planting. ✓
- tops broken or bent at the neck when leaves start drying.

This hastens withering of the stem ✓

- bulbs are dug and left to dry in a shade of a few days.

Turning should be done daily during drying

- dry onions should be stored in slatted wooden crates ✓
- regular inspection to discard spoilt ones should be done ✓

(1x4=4mks)

- b) - Damping off ✓
- black rot ✓
 - downy mildew ✓

(1x3=3mks)

4 Thinning, weeding, topdressing and pest control.

5. (a) Choose a suitable nursery site, considering accessibility and source of water

- Dig and prepare the chosen site to a desirable tilth
- Remove roots of previous plants and stones from the site
- Make raised or sunken nursery beds (depending on soil moisture) measuring 1m wide and any convenient length
- Plant seeds by drilling at a spacing of 15cm by 3cm deep
- Apply fertilizer (phosphatic) or manure
- Cover the seeds to a depth of about 1 cm
- Erect a shade or apply some mulch on the nursery
- Water the nursery thoroughly. **(7 well**

described pts = 7mks)

(b)

- Remove the mulch (if it was applied) and erect shade (if it wasn't erected) above the nursery
- Water the nursery at least twice a day preferably early mornings and late evenings
- Remove weeds that may have come up
- Thin young seedlings if they are overcrowded. Plant them in a seedling bed
- Control pests and diseases when the symptoms of attack are noticed
- Harden off the seedlings by removing shade gradually and reducing frequency of watering **(6 pts well described = 6mks)**

(c)

- Water the nursery thoroughly before transplanting
- Prepare the field/ seedbed to a suitable tilth before transplanting is due
- Transplant seedlings when 6-10cm high; selecting the healthy and discarding the weak ones
- Transplant during cloudy day or during late afternoon
- Plant seedlings in the field to the same depth (10cm) they were in the nursery space at 60cm x 60cm or 60cm x 90cm
- Lift each seedling from nursery with a ball (lump) of soil to avoid damage to the roots
- Water the field well before it receives the seedlings
- Apply a handful of FYM mixed with some phosphatic fertilizer in each hole

(Well described 7 pts scores 7mks)

6.

- Prevent attack by soil borne pests
- Facilitate spraying and harvesting
- Control soil borne diseases

– For the production of clean fruits
(1x4=4mks)

7. Prolonged maturity; cracking of fruits b4 maturity; blossom end rot; excess vegetative growth.
8. Too much nitrogen in early stage; irregular watering; calcium deficiency in young fruits.
- 9 Production of clean fruits; facilitate spraying and harvesting; avoid infestation by soil borne pests; control disease incidences such as blight.
- 10 Fresh market – money maker, hot set, super marmande, ponde rosa, marglobe.
Processing – primabel, cal J, seinz, Kenya beauty.
11. Brunswick, sugar loaf, early jersey, mukuki, Copenhagen market, golden acres, Gloria etc.
12. Encourages forking.
13. -Fresh market – chantenary
-Canning - Nantes

FORM THREE AGRICULTURE NOTES

CROP PRODUCTION IV

{FIELD PRACTICES (II)}

- There are many food crops grown in Kenya. These crops require different environmental conditions and are therefore found in different ecological zones in the country.
- Crops such as maize, beans and rice are grown as staple food crops. Other like millet, sorghum, cassava and sweet potatoes are mostly grown for food security.

Examples of food crops grown in Kenya

I) MAIZE (*Zea Mays*)

-It is the staple food in most areas in Kenya. Maize is also a livestock food and produces oil and starch when processed in industries.

Ecological Requirements

- Altitude-2200m above sea level
- Temperature-medium
- Rainfall-medium

Maize is drought tolerant during the early stages of growth but must have enough rain during silking stage.

- Soil-maize prefers fertile alluvial or loam soils since maize cannot tolerate water logging. Soil pH should be neutral to alkaline.

Maize Varieties

Few pure varieties exist because farmers tend to grow the Hybrids and Composites, which are more productive. The Kenya Flat Complex is an example of the few pure varieties. It is however low yielding.

Hybrids are bred by crossing two pure lines or varieties under conditions of controlled pollination.

Composites are bred by growing a number of varieties together under uncontrolled pollination i.e. there is free inter pollination.

The hybrids and composites are produced for specific altitudes in the country. E.g.

- Kitale Hybrids-614, 622, 625, 626, 627 and 628 are grown in medium to high altitude zones.
- Embu Hybrids-511 & 513 are best for medium altitude zones.
- Katumani Composites- for lower altitude zones
- Coast Hybrids- Pwani Hybrid 1 and Pwani Hybrid 4 for Coast Province.
- Others –Double cob DH01 & DH02

Selection and preparation of planting materials

Kenya Seed Company contracts specific farmers to grow maize for seeds. The maize is harvested and treated using *Thiram-dindane* to prevent post attack. Its then sold to farmers as seeds. Farmers should buy fresh seeds every planting season to escape the problem of reduced hybrid vigor.

Land Preparation

Land should be prepared early to allow the previous crop incorporated into the soil to rot. Disc or mould board ploughs are used to plough. Harrowing is done to obtain a fine tilth. Continuous cropping of maize should be avoided. It should be rotated with other crops such as beans, cotton, tobacco, Irish potatoes or groundnuts.

Field Operations

a) Planting

-Should be done early so that the crop can utilize the available moisture. Dry planting should be practiced in areas with short rainy seasons. Early planting increases yields and reduces attack by stalk borers. Seeds are planted shallowly in moist soils-2.5cm and deeply in dry soils-10cm.

Spacing is 20-30cm x 75-90cm where one or two seeds are placed per hole. However, spacing depends on the ecological conditions and the variety to be planted.

Small-scale farmers use hands to plant while tractor drawn planters are used on large scale.

b) Fertilizer Application.

100-150kg or DSP or DAP per hectare is applied during planting.

Top dressing is done when the crop is about 45cm high where 200kg of ASN or CAN is applied per hectare.

Top dressing can be done twice i.e. first when 45cm high and second one just before selling.

c) Weed Control.

Weeds should be controlled to reduce competition for moisture and nutrients. Two to three weeding are required during the growing period of the crop. Hand weeding is the commonest herbicides can also be used e.g. *Simazine*, and *Triazine* which are applied before the crop germinates and *MCPA* & *2,4-D* which are applied after the crop has emerged.

d) **Pest and Disease Control**

1. PESTS

a) Field Pests

i) Maize stalk borer (***Buseola fusca***)

It's the larval stage of the moth and attacks maize from the early stages of growth by making holes in leaves. In older plants, caterpillars bore into the stem and cobs.

Control

-Early planting

-Rogueing

-Burning infected maize crop remains

-Use of pesticides e.g. *Endosulfan, Diazinon, Dipterex, Malathion and Stalk borer dust*

ii) Army worm (***Spodoptera exempta***)

They are also larvae of the moths. The caterpillars are greyish-green in colour with black stripes at the back and both sides. They eat the leaves causing defoliation such that only the midribs are left.

Control

-Use of chemicals e.g. *Malathion, Diazinon*

iii) Aphids (***Rhopalosiphum maidis***)

The pest sucks sap from the green husks of cobs and leaves. Attacked husks and leaves appear blackish.

Control

Use of chemicals e.g. *Diazinon, Malathion* etc.

iv) Birds.

Mainly they eat the grains at the milking stage.

Control

-Scaring them away.

b) Storage Pests

i) Maize Weevil (***Sitophilus zeamais***)

It's the most serious storage pest of maize. It may also attack maize while still in the field. They make tunnels beneath the seed coat and circular holes on the surface of the grain.

Control

- Dusting with *Malathion*.
- Spraying methyl bromide onto the shelled maize
- Proper storage hygiene ie sweeping and removing old crop.

ii) Red flour Beetle (*Tribolium castaneuum*)

Are small reddish-brown beetles, which feeds on flour and broken grains.

Control

- Proper storage hygiene

iii) Rats (*Rattus rattus*)

-They attack fallen or stoked maize in the field. They are more serious however in the store.

Control

- Use of rat proof stores
- Use of cats.
- Use of traps
- Use of poisoned baits
- Bush clearing around the store.

2. DISEASES

i) White Leaf Blight.

It's a fungal disease caused by a fungus called *Helminthosporium turcicum*

It causes oval gray and thin lesions on the leaves.

Control

- Planting resistant varieties.

ii) Maize streak

-Caused by virus spread by grasshoppers. The disease causes yellow longitudinal stripes, which run parallel to the mid rib.

Control

- Use of certified seeds
- Early planting
- rogueing

iii) Rust

Disease is caused by *Puccinia sorghi* and *Puccinia polysora*

The disease forms red or brown spots on the leaves.

Control

-Planting resistant varieties

ii) Smut

-It's a fungal disease caused by *Ustilago zeas*. The disease destroys grains and tassels causing masses of black powder.

Control

-Crop rotation.

HARVESTING MAIZE

-The period between planting and harvesting varies depending on the variety and altitude.

-The stalks are cut and stoked in the field to allow the cobs to dry properly.

-Cobs are then removed by hand and placed in the store.

-Harvesting can also be done using combine harvesters.

-The grains should be dried completely to 12% moisture content before storage.

-Yields-3,00kg-4,500kg/hectare.

Storage

-Maize can be stored on cobs or it can be shelled and stored in bags

-The store should be properly constructed to keep out moisture and pests.

-Proper store hygiene should be observed to prevent losses through pests, diseases and other damages.

-Proper drying of the grains reduces chances of the grains rotting and minimizes the extent of insect damage.

Marketing

-Farmers sell their maize grains through the National Cereals and Produce Board.

-Local trading in green and dry maize is also common.

II) FINGER MILLET (*Eleusine coranaca*)

Finger millet has small seeds which dry out quickly and insects cannot fit inside them.

It's an important cereal crop in Western Kenya and Uganda.

Ecological Requirements

-Rainfall-about 900mm annually. Millet can tolerate drought in the early stages of growth but after the first month it requires a good supply of moisture.

-Altitude-0-2400m above sea level.

-Soils-should be fertile and well drained.

Varieties

-Ultra lupin

-5.18 OATS. Both are high yielding and resistant to lodging and blast.

Selection and Preparation of Planting Materials

-Harvested grains are sun dried, threshed, winnowed and then stored for use as seeds

-Certified seeds can also be bought from the Kenya seed Company.

Land Preparation

-Seedbed should be thoroughly prepared to obtain a fine tilth since the seeds are very tiny.

-Weed control is also very difficult in millet hence thorough seedbed preparation reduces weed competition.

Field Operations

a) Planting

-Should be done as early as possible in the season. The earlier it is sown the higher the yields.

-Planting is usually done broadcasting hand.

-If planted by rows, the furrows should be 30cm apart and the plants should be thinned to 5 cm apart within the rows.

b) Weed Control.

-This is done manually because finger millet is very close and jembe cannot be used.

-Thorough seedbed preparation reduces the labour required for weeding

-The most common weeds are the *Eleusine africana* and *Eleusine indica* (wild finger millet). They are difficult to distinguish from the crop in the early stages of growth.

c) Fertiliser application.

-125kg of Sulphate of Ammonia is applied when the crop is 15cm high.

d) Pest and Disease Control

i) Pests

-Finger millet is rarely destroyed by pests in the store because of the small size of the grains.

-Major pests in the field are the birds and are controlled by scaring them.

ii) Diseases

-Most serious disease is the head blast caused by a fungus called *Pericularia oryzae*

-The disease is common under hot and humid conditions e.g. in Western Kenya.

-The disease cause brown spots with grey centres on the leaves and the stems just below the inflorescence.

Control

-Planting resistant varieties.

Harvesting

-Hand knives are used for cutting individual heads. Heads are then dried, threshed and winnowed.

Yields

-1650kg/hectare can be obtained with good management practices.

Storage and Marketing

-Grains are dried and stored in bags.

-Mainly it's grown for subsistence and only a little is sold in local markets.

III) BULRUSH MILLET (*Pennisetum typhoides*)

It's one of the small cereal crops cultivated in lower parts of Meru, Kirinyaga and Embu districts. Also cultivated in Kerio valley and parts of Machakos.

Ecological Requirements

Rainfall-500-600mm p.a. Bulrush millet is drought resistant and takes a short time to mature.

Altitude-1200m above sea level hence warm climate.

Soils-should be well drained.

Varieties

Severe 26/19, 17, 26/9, 6A, 2A and 3A.

Land Preparation

Land should be prepared early to give the soil enough time to settle and form a firm seedbed. A fine seedbed is required since the seeds are tiny.

Field Operations

a) Planting

-Planting is commonly done by broadcasting followed by a shallow cultivation before the onset of the rains.

-Spacing should be 60cm x 15cm where rows are used.

b) Weeding

The field should be maintained weed free until tillering occurs. Hand weeding is commonly done.

c) Fertiliser Application.

Sulphate of Ammonia can be applied at the rate of 200kg/hectare when the crop is 30cm high.

d) Pest and Disease Control

i) Pests.

-Main pests in the field are quelea, weaverbirds and bishop's birds.

-These destroy the grains when they are in the milking stage onwards.

Control

-Scaring them.

ii) Diseases.

▪ Downy Mildew

- A fungus called *Sclerospora graminicola* causes disease
- Causes whitish lines on the leaves

Control

- Planting resistant varieties.
- Destroying crop remains.
- Crop rotation.

▪ Rust.

- Caused by a fungus called *Puccinia penniseti*
- It causes pustules that develop on the leaves

Control

Planting resistant varieties

▪ Ergot

- Caused by a fungus called *Claviceps microcephala*
- Affected heads become sticky

Control

- Planting certified seeds
- Crop rotation
- Destruction of infected crop residue.

Harvesting

- It's done by cutting the heads with a knife or sickle when they have dried.
- Threshing is done by beating the dry heads on the ground

Yields

Up to 1000kg/hectare can be obtained under good management.

Storage and marketing

- After threshing, the grains are winnowed and dried up to 14% moisture content and then stored in bags.
- Millet is mainly grown for subsistence and is sold locally.

IV) SORGHUM (*Sorghum vulgare*)

-It is an important cereal crop in Kenya. It is grown in Western and Northern Rift Valley, Eastern and some parts of Central province.

-Sorghum can be ratooned. Sorghum grains are ground for flour, which is used for making porridge or for brewing.

-Young growing crop may be used as direct animal feed or may be used to make silage.

Ecological Requirements

-Rainfall-420-630mm p.a.

-Sorghum is drought resistant since it has a well-developed rooting system and has the ability to roll the leaves during hot weather.

-Altitude-0-1500m above sea level. At higher altitudes, poor yields are obtained and pests and diseases attack the crop.

-Soil-the crop requires fairly fertile and well-drained soils.

Varieties

i) Dobbs

It was selected in western Kenya. It's suitable for areas around Western Kenya. The seeds are brown and mature in about 4 months.

ii) Serena

Was obtained by crossing Dobbs with a variety from Swaziland. It has brown seeds and matures in about 3 ½ months.

Selection and Preparation of Planting Materials

Seeds are prepared by threshing the dry heads, winnowing and seed dressing.

Field Operations

a) Planting

-Normally done by broadcasting the seeds on a firmly prepared seedbed.

-Spacing is 60cm x 15cm if planted in rows.

b) Fertilizer Application.

-Fertilizers not commonly used. However, crop responds well to farmyard manure on moist soils

c) Weeding.

The field should be kept weed free.

d) Pest and Disease Control.

a. Pests

Birds

-Are the major pests e.g. *Quelea quelea aethiopica* (Sudan dioch), weaverbirds, bishop's bird, starling etc.

Control

-Planting resistant varieties, e.g. the Goose necked varieties.

-Killing the birds using flame throwers, explosives or poison sprays in their breeding colonies.

N/B some sorghum varieties have a natural quality, which keeps birds away such as persistent bitter tasting coats.

Sorghum shoot fly. (*Antherigona varia*)

The adult lays eggs on the underside on the leaves. The eggs hatch into larvae, which enter the funnel, and move down to feed on the young stem.

Control

-Early planting.

-Use of insecticides

-Closed season.

Stem borers

There 3 main species of stem borers attacking sorghum. These are:

Buseola fusca

Chillo zonellus

Sesamia calamistis.

Control.

-Use of insecticides.

-Proper disposal of crop residue/remains after harvesting.

b) Diseases

Sorghum is attacked by both leaf and inflorescence diseases.

Examples of leaf diseases

- Leaf blight (*Helminthosporium turcicum*.)
- Anthracnose (*Colletotricum graminicola*)
- Sooty stripe (*Ramulispora sorghi*)

General control

- Growing resistant varieties.

Examples of inflorescence diseases

Loose smut (*Sphacelotheca cruenta*)

Head smut (*Sphacelotheca reiliana*)

General control

Seed dressing.

Harvesting

- Sorghum is ready for harvesting 3-4 months after planting.
- Heads are cut off using a sharp knife after which they are sun dried.
- Dried sorghum is then threshed, winnowed and stored.

Yields

- 500-1500kg/hectare and up to 3000kg under good husbandry.
- Sorghum can be ratooned for one or two seasons.

Marketing

- Crop is marketed through the National Cereals and Produce Board.
- Private buyers also purchase sorghum directly from farmers.

V) BEANS (*Phaseolus vulgaris*)

- Are used to provide with proteins. They are grown for the dry seeds or for the green pods. Beans can be intercropped with other crops like maize and cassava.
- Beans are annual legumes with varying growth habits. E.g. some varieties are determinate bush type (non-spreading) and others are indeterminate type (spreading type)
- Beans are about 99% self-pollinated.

Ecological Requirements

- Soil
- Should be well drained and rich in organic manure. Beans do not tolerate waterlogged soils.
- The soil should be moist.
- Rainfall
- Should be moderate. Heavy rainfall is destructive at the flowering stage. Rain should be present during harvesting time, as this would cause rotting and sprouting of the beans. Beans for green pods are produced under irrigation.

Varieties

- Varieties for production of dry bean seeds
 - Rose coco, (GLP 2)
 - Mwezi moja (GLP 1004)
 - Canadian wonder (GLP 24)
 - K 74
 - Wairimu
 - Mexican 142 developed in Tanzania. It is suitable for canning, drought resistant, rust resistant, early maturing and high yielding.
- Varieties for green pods production. (*French Beans*)
 - Long tom
 - Saxa
 - Master piece
 - Monel.

Selection and Preparation of Planting Materials

-Beans are established from seeds. The seeds should be dried before they are planted. Damaged and wrinkled seeds should be discarded during seed selection. Selected seeds should be dressed with appropriate chemicals to control soil borne pests. Seeds should be inoculated with the right strain of *Rhizobium*.

Field Operations

- a) Planting
- Beans should be planted at the onset of rains. 2-3 seeds are placed per hole at a spacing of 30cm x 15cm. DAP fertilizer

should be applied at a rate of 200kg/hectare along the furrows before planting. The seed rate is 50-60kg/ha.

b) Weeding

-The field should be kept weed free by shallow weeding. Weeding should be done before flowering to avoid knocking down the flowers. Weeding is done when it is dry to avoid spreading diseases.

c) Irrigation.

-Beans for green pod production are grown during the dry months. They therefore need about 50mm of water per week. This is supplied through overhead irrigation or furrow system of irrigation.

d) Pest and Disease control.

i) Pests

-They include aphids, American bollworm, bean fly, spotted borer, golden ring moth etc.

Control

Spraying with insecticides such as *Dieldrin*, *Dimethoate*, *Diazinon*, and *Formathion* etc.

ii) Diseases.

-They include Bean rust, Anthracnose, Halo blight and angular leaf spot.

o Bacterial (Halo) blight.

Caused by a bacteria called *Pseudomonas phaseolicola* Disease causes brown water soaked lesions on the pods. Each brown spot is surrounded by a yellow band or 'halo'. The disease is seed borne and can be spread by rain, which could splash the bacteria on to the healthy plant parts.

Control

-Planting healthy seeds.

-Rogueing

-Crop rotation

-Spraying with *copper oxychloride*.

o Anthracnose.

Disease is caused by a fungus called *Colletotricum lindemuthianum*.

It causes brown lesions on pods and stems and brown spots on leaves.

Control

- Growing resistant varieties e.g. K74 and Wairimu.
- Use of clean seeds.
- Seed dressing with *Captan*
- destroying infected crop residues.
- Spraying with *Benomyl*, *Copper fungicide* or *Mancozeb* during the wet season.

Harvesting

Beans for seeds are harvested by uprooting the dry plants.

Uprooted beans are gathered on tarpaulins/canvas, mats or sacks to allow them to dry further before threshing.

When the plants are dry enough, they are beaten with sticks to remove the seeds from the pods.

The stems and the pods are removed before winnowing.

Sorting should be done after winnowing to remove damaged seeds.

Dry clean seeds are treated with appropriate pesticide and packed in bags.

Marketing

- Is done through NCPB

Yields

- 2600kg/ha under good management

For the green beans (French beans), harvesting of the pods starts about 9 weeks after planting and continues for about two months.

Pods should be packed immediately after picking to avoid shrivelling.

Yields

- 4-5 tones/ha under good management.

V) RICE (*Oryza sativa*)

-Rice is a cereal crop and is used as a staple food in some parts of Kenya.

-It is grown at Mwea Tebere irrigation schemes in Kirinyaga district, Ahero irrigation scheme in Nyando district and Bura irrigation scheme in Tana River district and Yala swamp in Siaya district.

-Mwea is the largest rice-growing project in Kenya with over 5,600 hectares.

Land Preparation

-Rice growing fields are levelled and bunds constructed around them for controlling water.

-Tractor drawn rotavators are used to work the flooded fields before transplanting.

Field Operations

a) Water control.

The level of water is increased from the very low level of about 5cm at planting time gradually to a height of 15cm by the time the seedlings are fully grown. Water should be allowed to flow slowly through the fields.

b) Fertilizer Application

Sulphate of Ammonia should be applied at a rate of 25kg per each nursery unit measuring 18.5cm x 18.5cm before sowing. DSP fertilizer is broadcasted in the field at a rate of 125kg/ha before transplanting and 125kg/ha 40 days after transplanting.

c) Weed Control.

Flooding easily controls weeds. Uprooting can be done on the few weeds that persist.

Herbicides can be used e.g. *Butachlor* and *Propanil*.

HARVESTING OF VARIOUS INDUSTRIAL CROPS

CROP	Method and Procedure of Harvesting	Precautions During Harvesting
------	------------------------------------	-------------------------------

<p>Cotton (Matures 4 months after planting)</p>	<ul style="list-style-type: none"> -Done by picking manually. -Seed cotton is sorted into 2 grades i.e. (Safi) & BR (fifi). -AR is free from insects and is clean white -BR may not have all the required qualities. 	<ul style="list-style-type: none"> -Foreign matter e.g. leaves should not be mixed with seed cotton. -Picking shouldn't be done when its wet -Sisal bags should not be used as their fibres may mix with seed cotton.
<p>Pyrethrum (Ready for picking 3-4 months after planting)</p>	<ul style="list-style-type: none"> -Flowers are picked selectively. -Only those with horizontal petals are picked. -Picking interval is 14-21 days -Flowers are picked by twisting the head so that no stem is attached 	<ul style="list-style-type: none"> -Picked flowers should be put in open woven baskets. -Wet flowers shouldn't be picked. -Tins and polythenes should not be used because they cause the flowers to ferment hence low <i>pyrethrin content</i>. -Flowers should not be compacted
<p>Sugarcane (Takes 12-20 months to mature)</p>	<ul style="list-style-type: none"> -Cane should be cut at the ground level. -Tops are removed and leaves are stripped. 	<ul style="list-style-type: none"> -Harvested cane should be delivered to factory within the first 24 hours.

	<ul style="list-style-type: none"> -Harvesting is done using the cane harvesting machet. -Best quality cane should have uniform sugar distribution. 	<ul style="list-style-type: none"> -Delay reduces the sugar content in the canes.
<p>Coffee (Matures after 3-5 years. It takes 8-9 months from flowering to the maturation of the berries)</p>	<ul style="list-style-type: none"> -Red ripe berries are picked by hand. -Diseased ones are later sorted out. -Any dry, undersized or green ones are dried & are referred to as Buni. -During peak period, coffee is harvested once a week. 	<ul style="list-style-type: none"> -Picked berries should be delivered to the factory immediately. -Delay leads to reduced quality.
<p>Tea (Takes 2-4 years to commence picking depending on how its brought to bearing and the altitude</p>	<ul style="list-style-type: none"> -The two top leaves and the bud are picked. --- These leaves have the highest caffeine content. -A plucking stick is used to maintain the plucking table. -Plucking interval is 5-14 days depending on the season. -Plucked tea is put in woven baskets, which allow free movement of air. 	<ul style="list-style-type: none"> -Leaves should not be compressed. -Plucked tea must be kept cool under shade. -Plucked tea should be taken to the factory the very day of plucking.

FORAGE CROPS

These are plants, which grow naturally or are planted by man and are used as livestock feed.

PASTURES

A pasture is the land on which the forage crops *are grazed on directly*.

Aspects of pasture

- a) Pasture classification
- b) Pasture establishment
- c) Pasture management
- d) Pasture utilization.

A) PASTURE CLASSIFICATION

Pasture can be classified in three main ways.

- i) According to the pasture stand
- ii) According to pasture establishment
- iii) According to the Ecological zones.

i) Classification on Basis of Pasture Stands.

The pasture may be either pure stand or mixed stand.

Pure stand pastures have either grass or legumes on them. In mixed pastures, grasses and legumes are grown together.

ii) Classification based on Establishment.

Under this category, pastures are classified as Natural and Artificial.

- Natural pastures.

These are grasses and legumes grow naturally and extensively for both domestic and wild animals. Over 80% of Kenyan pastures are natural. They are mainly mixed stand pastures.

- Artificial pastures.

These are pasture grasses and legumes planted by man purposely for livestock feeds. Mostly they are of high quality.

iii) Classification on the basis of Altitude (zones)

Under this category, pastures can be classified as:

- High altitude pastures (grasses & legumes)
- Medium altitude pastures
- Low altitude pastures.

High Altitude Pastures

They are found at high altitudes of 25500m above sea level and above. They are green showing vigorous growth throughout the year. They are suitable for dairy and sheep farming. Examples:

Grasses

Common Name	Botanical Name
1. Kikuyu grass	<i>Pennisetum clandestinum</i>
2. Nandi setaria	<i>Setaria sphacelata</i>
3. Molasses grass	<i>Molinis minutiflora</i>
4. Giant setaria	<i>Setaria splendida</i>
5. Rhodes grass	<i>Chloris gayana</i>

Legumes

Common Name	Botanical Name
1. Kenya white clover	<i>Trifolium repers</i>
2. Louisiana white clover	<i>Trifolium semipilosum</i>
3. Subterranean clover	<i>Trifolium subterrianeum</i>
4. Lucerne	<i>Medicago sativa</i>

Medium Altitude Pastures

These are pastures found between 1500-2500m above sea level. This altitude favours beef, goat, sheep and dairy farming.

Examples of grasses in this zone.

Common name	Botanical Name
1. Rhodes grass	<i>Chloris gayana</i>
2. Nandi setaria	
3. Star grass	<i>Cynodon dactylon</i>
4. Makueni guinea	<i>Panicum maximum</i>
5. Congo signal	<i>Branchiaria yuziziiensis</i>
6. Malara guinea	<i>Panicum coloratum</i>
7. Giant Setaria	
8. Guatemala grass	<i>Trysacum laxum</i>

Examples of legumes in this zone.

Common Name	Botanical Name
1. Lucerne	<i>Medicago sativa</i>

- | | |
|---------------------------------|---------------------------------------|
| 2. Silver leaf desmodium | <i>Desmodium uncinatum.</i> |
| 3. Green leaf desmodium | <i>Desmodium intortum.</i> |
| 4. Siratro | <i>Macroptilium</i> |
| <i>atropurpureum</i> | |
| 5. Stylo | <i>Stylosanthes guianensis</i> |

Low Altitude Pastures

These are pastures found in marginal areas of Kenya below 1500m above sea level which receive little rainfall. In such areas, indigenous livestock such as camels, donkeys, cattle, sheep and goats are kept.

Examples of grass pastures in this zone include:

Common Name	Botanical Name
1. African fox tail	<i>Cenchrus ciliaris</i>
2. Maasai love grass	<i>Eragrostis superba</i>
3. Likoni guinea	<i>Panicum maximum</i>
4. Makarikari grass	<i>Panicum coloratum</i>
5. Red oat grass	<i>Themeda triandra</i>
6. Hyparrhenia (thatch grass)	<i>Hyparrhenia rufa</i>
7. Giant star grass	<i>Cynodon plectostadyns</i>
8. Bothriochloa	<i>Bothriochloa insulpa</i>
9. Para grass	<i>Branchiaria mutica</i>
10. Andropogon	<i>Andropogon spp</i>
11. Cymbogon	<i>Digitaria decumbeus</i>

Examples of legumes found in this zone.

Common Name	Botanical Name
1. Stylo	<i>Stylosanthes searbra</i>
2. Glycine	<i>Glycine wightii</i>
3. Centro	<i>Cenrosema pubescens</i>

OTHER PASTURE CROPS

Weed Grasses

Common Name	Botanical Name
1. Couch grass	<i>Digitaria scalarum</i>
2. Nut sedges	<i>Cyperus species</i>

3. Sporobolus *Sporobolus spp.*
 Fodder shrubs
1. Leucaenia *Leucaenia leucocephala*
 2. Atriplex *Atriplex spp.*

B) PASTURE ESTABLISHMENT

Pasture can be established by use of seeds, rhizomes or splits.

i) Selection of Planting Materials.

Planting materials selected should be;

- Of high nutritive value.
 - Adapted to the prevailing environmental conditions.
 - Fast growing in order to give a good ground cover which will help to control soil erosion.
 - Able to give high herbage yield per unit area.
- ### ii) Land Preparation.
- Land should be ploughed and harrowed to a fine tilth.
 - Land preparation should be done during the dry season before the onset of the rains.

iii) Seed Rates

Recommended seed rate for pasture grasses is 1.5-2.0kg/ha of pure germinating seeds. The seeds are produced by Kenya Seed Company. And are sold in two lots

- High quality seeds with 13-25% pure germinating seeds. (PGS)
- Standard quality seeds with 12.5% PGS.

Legume seed rate depends on the seed size i.e. 2-3kg/ha for medium sized seeds e.g. Desmodium and Lucerne and 2kg/ha for tiny seeds e.g. clovers.

iv) Fertilizer Application.

- SSP fertilizer is applied at a rate of 200kg/ha for grasses and legume mixtures
- For pure grasses, NPK 20:20:0 at a rate of 200kg/ha is recommended.

v) Legume Seed Inoculation

- This is the addition of effective Rhizobia to leguminous seeds before planting to promote nitrogen fixation.
- This is done in areas where soil is deficient of nitrogen.
- Some Rhizobia strains are naturally found in the soil at pH 5.5-8.0 with adequate calcium, phosphorous, potassium and rainfall.

Examples of Rhizobium strains.

Crop	Rhizobium Species
○ Lucerne	Rhizobium melioli
○ Clovers	Rhizobium trifoli
○ Beans	Rhizobium phaseoli.

vi) Sowing.

Since most seeds are small, they should be covered lightly after broadcasting. The following are the methods of sowing.

- Direct sowing
- Under sowing
- Over sowing.

Direct Sowing.

>This is the establishment the pasture in a clean seed bed where no other crops are growing

Under Sowing

>This is the establishment of a pasture under a cover crop usually maize.

>Maize is planted and weeded 2-3 weeks after the onset of the rains.

>Pasture seeds are broadcasted with the recommended amount of fertilizer.

>No further weeding is done

>Maize is harvested early to expose the young seedlings to sunlight.

Over Sowing

>This is the establishment of a pasture legume in an existing grass pasture.

>The grass pasture is kept short until the pasture legume is well established.

>SSP fertilizer is applied at the rate of 200kg-400kg/ha.

>The mixed stand pasture should be ready for light grazing 4-5 months after planting.

C) MANAGEMENT OF PASTURES.

i) Weeding

Weeds should be controlled as they cause the following;

- Reduce the lifespan of pastures.
- Compete with forage crops for nutrients, moisture and sunlight.
- Reduce the quality of the Herbage yield.
- Some may be poisonous to the animals e.g. Datura.
- They interfere with forage fertilization.

Weed Control measures on pastures

- Timely land preparation which ensures clean seedbed with less subsequent weed problem.
- Slashing.
- Application of selective herbicides e.g. 2,4-D.
- Uprooting the weeds if scattered.

ii) Top Dressing.

This is the application of plant nutrients after the pasture has established for the following reasons.

- To add/replenish soil nutrients and ensure proper nutrient balance.
- To increase the herbage yield
- To improve the nutrient value of the crop.
- To enable the soil micro organisms to breakdown organic residues into available nutrients
- To correct or amend both physical and chemical properties such as soil structure and moisture holding capacity.

N/B The choice of topdressing fertilizer depends on the crop and soil nutrient status.

-Inorganic fertilizers are better for top dressing materials than organic manures because they release their nutrients faster.

-Pure grass pastures require large amounts of nitrogen and potassium.

-Grass-legume pastures require phosphorous, potassium, calcium and sulphur for nitrogen fixation.

iii) Topping.

-This is the removal of the stemmy fibrous material left over after a period of pasture grazing.

-The removal of such material stimulates fresh growth.

-Topping should be done at the onset of the rains and should be followed by topdressing.

-Topping is done through slashing, mowing or burning.

iv) Reseeding.

This is also called gapping and it's done when pasture is partially denuded or bare. Refilling the gaps does it.

v) Controlled Grazing.

Some pastures are seriously affected by heavy grazing such that herbage production is low. Grazing has therefore to be controlled through tethering, strip grazing or paddocking.

vi) Pest Control

Just like any other crop in the farm, pasture crops are also attacked by pests. The most common pest is the mole which makes underground tunnels destroying roots of pasture crops hence killing them. These are controlled by

- Use of cats (Biological method)
- Rodenticides (Chemical control)
- Traps (Physical/mechanical method)

D) **PASTURE UTILIZATION FORAGE QUALITY**

- The quality of forage declines with age. I.e. there is gradual decline in the amount of soluble sugars,

starch, proteins, organic matter and digestibility with age.

- Crude fibre is not digestible in the normal enzymatic process but only through the activities of microbes in the rumen.

Frequency of Defoliation.

- Defoliation refers to grazing in pastures and cutting for feed in fodder crops.
- Frequency of defoliation therefore refers to how often the forage stand is grazed or cut for feed.
- It's important to determine the proper defoliation frequency for a particular forage.

Effects of Very Early Defoliation (Less than Four weeks.)

- The forage has very high moisture content (90%)
- The forage has very high protein content on weight basis.
- Has very low Dry Matter content hence very low DM yield.
- It has high DM digestibility but low in digestible nutrients.
- Has low crude protein yield.
- Frequent early defoliation leads to a gradual weakening of the stand followed by empty patches, weed invasion and an eventual reduction in the productive life of the stand.

Effects of Late Defoliation. (More than Ten week

- The forage has high DM content hence high DM yield
- Has high cellulose content hence it's woody and fibrous.
- It has high lignin, cutin, tannin and silica content which are all insoluble.
- It has low crude protein content.
- It has low leaf: ratio

- It has low dry matter digestibility

NB/ during grazing, it's necessary to do paddocking for the following reasons.

- To control grazing and ensure sufficient re-growth before grazing is resumed.
- To ensure better forage utilization and less wastage by trampling, fouling and selective grazing.
- To facilitate conservation of excess pasture in form of hay or standing forage.
- To maintain a favourable grass-legume balance where applicable.

Carrying Capacity and Stocking Rate

Carrying capacity is the ability of the forage stand to maintain a particular number of livestock units per unit area. This depends on the herbage yield and the animals' daily requirements.

Stocking rate refers to the number of the animals maintained per unit area of land.

In order to determine the carrying capacity and the proper stocking rate for a particular forage stand, dry matter (DM) yields per unit area per unit time and live weight of the animals to be fed are considered.

Example

A dairy animal consumes 2.5kg dry matter for every 100kg body weight per day.

- The amount consumed by a jersey weighing 400kg live weight per year would be
 $2.5 \times 400 / 100 \times 365 / 1000 = 3.65$ tons DM
- A Guernsey weighing 450kg would consume
 $2.5 \times 450 / 100 \times 365 / 1000 = 4.1$ tons DM
- Likewise, an Ayrshire weighing 500kg live weight would consume,
 $2.5 \times 500 / 100 \times 365 / 1000 = 4.65$ tons DM.

NB/ when the stocking rate is above the carrying capacity of the pasture, it is referred to as overstocking. And when it is below the carrying capacity it is referred to as under stocking.

Some Recommended Stocking Rates on Different Pastures

Grass	Dm yield/ha/year (tonnes)	Carrying capacity (Livestock Units/Ha)
Napier grass	25 - 30.0	5 - 7
Rhodes grass	10.9 - 15.2	2.5 - 3.5
Nandi setaria	11.4 - 13.9	2.5 - 3.0
Makueni guinea	9.9 - 15.9	2.5 - 3.5
Star grass	5.3 - 9.1	1.3 - 2
Kikuyu grass	4.3 - 14.3	1.0 - 3.0

Effects of overstocking

- a) Insufficient regrowth period for the forage hence effects similar to those of very early defoliation.
- b) Overgrazing and loss of soil cover leading to soil erosion.
- c) Invasion of undesirable plant species especially weeds and shrubs.

Intensity of defoliation

This refers to proportion of the herbage removed through grazing and that of the residual forage. Pastures should be grazed until about 70% of the aerial herbage is eaten up i.e. about 5cm is left.

GRAZING SYSTEMS

There are three main grazing systems

- Rotational grazing
- Continuous grazing
- Zero grazing

1) Rotational Grazing

This refers to practice of allowing livestock to feed on a part of pasture for a period down to certain level before they are moved to the next. This gives time for pasture to properly regenerate.

Advantages of Rotational Grazing

- a) Livestock make maximum use of pasture
- b) Reduces the buildup of parasites and diseases.
- c) Animal waste is distributed evenly in all fields/paddocks.
- d) Pasture area is given time to re-grow before its grazed on again.
- e) Excess pasture can be harvested for conservation
- f) Its possible to apply fertilizers in parts of the pastures are not in use
- g) It facilitates reseeding and weeding.

The methods of rotational grazing include paddocking, strip grazing and tethering.

a) Paddocking

- A paddock is a fenced portion of a pasture in which animals are restricted for grazing.
- Paddocking means grazing livestock in one paddock for a short period and then moving to another.
- The size of the paddocks depends on the carrying capacity of the pasture.
- There should be a watering point at each paddock.
- A water trough is placed between two paddocks so that animals can drink water from either paddock.
- Paddocking saves herding labour. However, it is very expensive to construct.

b) Strip Grazing

-This is done by allowing livestock to graze on restricted portion of the pasture at a time then moving them to the next.

-It's done on very high quality pastures. Electric fences can be used to enclose animals in a given strip of pasture. -Where animals are not many herding may be done to restrict them to stay within the strips. Temporary fences may also be used instead of the electric fences.

-However, the system is quite expensive.

c) Tethering.

-This involves tying the animal to a post with a rope such that it feeds within a restricted area.

-The rope may also have a metal ring that slides along a strong wire supported by strong poles.

2) Continuous Grazing (Herding)

In this type of grazing, the pasture is not allowed any resting period. This method can easily result in overgrazing if the stocking rate is not controlled. It's common in the semi-arid areas.

3) Zero Grazing (Stall Feeding)

-This is the practice of rearing animals in a permanent feeding enclosure known as the stall. Feed is cut and taken to the animals in the stalls.

-They are also provided with plenty of clean water and mineral licks.

Advantages

- There is quick accumulation of manure
- Animals make use of the feeds without wastage
- Animals produce high yields due to less wastage of energy.
- It's easy to control diseases and parasites
- It requires little land
- It allows higher stocking rate

Disadvantages

- High initial capital is required
- High management skills are needed
- Need a lot of labour

- Diseases can easily spread.

FODDER CROPS

-These are forage crops which are grown, allowed to mature the cut and given to livestock as feed. Animals are not allowed to graze on them directly because they easily degenerate.

-The fodder can also be conserved and sold if produced on large scale.

-They include; Napier grass, Guatemala grass, Sorghum, Columbus grass, Sudan grass, Edible Cana, Kales, Kenya white clover, Marigolds (Sugar beets), Lucerne, Desmodium and Agro-forestry trees and shrubs.

1. NAPIER GRASS. (*Penisetum purpureum*)

There are two main varieties of Napier grass i.e. The French Cameroon and Bana Grass.

- French Cameroon It has thin stems and less hairy
- Bana Grass Has thick stems and its hairy.

a) Ecological requirements.

i) Soils

-Should be well drained though it does well in a variety of soils.

ii) Rainfall

- 750 mm p.a which should be well distributed.

iii) Altitude.

-Preferably 2100m above sea level.

iv) Temperature

-Optimum 24°C -29°C

b) Establishment and management

i) Land preparation.

Should be done early during the dry season. Furrows are made at a spacing of 90-100cm. Alternatively; holes can be dug at a spacing of 90cm x 50cm. 7-10 tons of well decomposed organic manure is applied.

ii) Planting.

Planting materials should be selected from desirable varieties of napier grass. Materials should come from healthy and mature plants. Stem cuttings or splits are used. Stem cuttings should have 2-3 nodes.

-Stem cuttings should be placed in the furrows in a slopping manner.

-NPK (20:20:0:) should be applied at rate of 200kg/ha.

iii) Fertilizer application

Topdressing with nitrogen and potassium fertilizers should be done about 6-8 weeks after planting.

iv) Weed Control.

Weeds should be removed as early as possible during the early stages of development. Methods of control include,

- Use of herbicides e.g. 2,4-D
- Cultivation
- Slashing
- Up-rooting.

v) Defoliation.

French Cameroon matures in about 3 months. There after it should be cut every 6-8 weeks. The grass should be about 1.2-1.5m high at the time of harvesting.

Bana Grass grows up to 12 months without flowering.

Defoliation should be done when there is high yield digestible matter.

vi) Utilisation.

Stems should be cut 2.5-5.0 cm above the soil surface to facilitate fast re-growth. A panga is used to cut. Excess napier is conserved as silage for future use. Cut forage is chopped into smaller pieces by use off a chaff cutter or a sharp panga.

vii) production per unit area.

Under good management, Napier grass gives a yield of up to 35 tons of dry matter (DM) per hectare per year. This contains 8-15% crude protein and this is enough to support 5 milking cows per year.

2. GUATEMALA GRASS (*Trypsacum laxum*).

It's a tall hardy, broad leafed grass with a vigorous growth.

a) **Ecological Requirements.**

i) Altitude

-Up to 2000m above sea level.

ii) Soils

-Does well in a variety of soils.

iii) Rainfall.

-900mm p.a. that should be well distributed.

b) Establishment and management.

i) land preparation

-Should be done early before the start of the rains. Land is ploughed and harrowed to a medium soil tilth removing all the perennial weeds.

ii) Planting

-Its established from cuttings or from splits. Furrows are made at a spacing of 1m apart. Splits are planted at about 0.5m apart within the rows.

-Holes can also be used.

iii) Fertilizer application.

-During planting NPK (20:20:0) is applied at a rate of 150kg/ha. Topdressing is done using nitrogenous fertilizers when the grass is 6-8 weeks old. Topdressing should be done after each harvesting subsequently.

iv) Weed Control.

The field should be kept weed free especially for the first few months of establishment. This is done by

- Uprooting
- Use selective herbicides
- Slashing
- Cultivation

v) Defoliation

It can be harvested at 8-12 weeks of age.

vi) Utilization.

Its chopped and fed to livestock as green fodder. Its suitable for stall feeding.

vii) Production per unit area

Yields are about 12 tons per hectare of dry matter per year.

This can support 2-3 cows comfortably.

3. SORGHUM (*Sorghum alum*)

There are two main varieties of sorghum grown in Kenya. i.e.

i) Columbus grass (*Sorghum alum*)

ii) Sudan grass (*Sorghum Sudanese*)

a) Ecological Requirements

i) Rainfall

650mm per annum which should be well distributed through the year.

ii) Altitude

Below 2100m above sea level.

iii) Soils

Grows in a wide range of soils

b) Establishment and Management

i) Land Preparation

Should be done early before the onset of the rains. A fine tilth should be obtained.

ii) Planting

Seeds are used and they are drilled or broadcasted. NPK (20:20:20) is applied at the rate of 200kg/ha during planting for proper root growth and development.

iii) Fertilizer Application.

CAN or ASN is top dressed at the rate of 125kg/ha

iv) Weed Control

Field should be kept weed free. This is done by hand cultivation, slashing or use of selective herbicides.

v) Utilisation.

Grass lasts in the field for 18 months. During this period, the grass is harvested several times. It regenerates after every

cutting. Columbus grass should be left to dry for two days before feeding to the animals to avoid *Prussic and Hydro cyanic acid poisoning*. This poison is found in wet grass.

Production Per Unit Area

-20 tons per hectare of dry matter (DM) per year under in good management.

4. KALES (*Brassica spp*)

They supply succulent nutritious stems and leaves for feeding livestock.

a) Ecological Requirement

- Soils should be loam or clay
- Rainfall > 1000mm
- Altitude prefer high altitude.

b) Establishment and Management.

Seeds are planted in nurseries 6 weeks before the rains. Land should be prepared to a fine tilth. Holes are dug at a spacing of 1m x 0.3m. Transplanting is done at the onset of rains. DSP fertilizer is applied at a rate of 150kg/ha when transplanting. The field should be kept weed free.

c) Utilisation

Leafy stems are cut, chopped and given to livestock. Kales should be fed to milking cows together with dry roughages since they are succulent. About 15kg of kale is needed by animal per day. It should be given to the milking cows after milking to avoid tainting the milk.

d) Production per unit area

Kales produce 35-50 tons fresh weight per hectares per year. Kales are quite rich in protein.

5. EDIBLE CANNA. (*Cana edulis*)

It's a fodder crop with broad shiny leaves which are used to feed livestock.

a) Ecological Requirement

- Rainfall-should be adequate
- Altitude-1500-200m above sea level
- Soils-should be fertile

b) Establishment and Management.

Land is cleared, ploughed and the harrowed. Holes are dug at a spacing of 1m x 1m. Farmyard manure is mixed thoroughly in holes before planting. Rhizomes are planted at the onset of rains. Early weeding is done. Crop is top dressed 4 weeks after planting with nitrogenous fertilizer at the rate of 100kgN/ha.

c) Utilisation

Edible canna is cut and fed to livestock when fresh. Each lactating cow should be given 4-7kg of canna per day during the dry seasons.

d) Production per unit area

Edible canna produces about 100tons DM/ha/year

6. SUGAR BEETS/MARIGOLDS (*Beta vulgaris*)

These are root fodder crops that are quite nutritious.

a) Ecological Requirements.

- Rainfall-more than 1000mm
- Altitude- should be high
- Soils –should be well drained.

b) Establishment and Management

They are established through seeds. Seeds are planted in nurseries 6 weeks before the rains. Land is cleared, ploughed, and then harrowed to a medium tilth. Holes are dug 1.0m x 0.3m. DSP is applied at the rate of 150kg/ha at planting time. The field should be kept weed free through cultivation, uprooting, slashing or by use of appropriate herbicides. Topdressing is done using CAN or ASN at the rate of 100kg/ha.

c) Utilization.

They are used for feeding livestock during the dry season at the rate of 22-27kg/cow/day. They are chopped into small

pieces. They should be wilted first because their fresh leaves have oxalic acid which can be poisonous.

d) Production per unit area.

Marigold produces between 30-40tons/ha of herbage under good management.

7. KENYA WHITE CLOVER (*Trifolium semipilosum.*)

It has slender spreading stems which produce roots and underground rhizomes.

a) Ecological requirements

- Altitude-2500-3000m above sea level
- Soils- should be well drained with a pH of 5.5

b) Establishment and Management

It's established from seeds. Seed are mixed with a nitro-culture and broadcasted in moist soils. It can also be over- sown with other pastures e.g. Nandi setaria and Rhodes grass.

c) Over-sowing

Clovers can be over-sown as indicated above.

d) Inoculation

It's the addition of the effective bacteria to the clover seeds before planting to promote the nitrogen fixation especially when grown in mixed stands.

e) Fertilizer Application

Phosphatic fertilizers can be applied.

f) Utilization.

Pasture should be harvested and the taken to the animals.

Direct grazing should not be done, as clovers do not withstand frequent heavy grazing.

8. LUCERNE (*Medicago sativa*)

It's a leguminous plant. It is also known as alfalfa.

a) Ecological Requirements

- Soils – should be well drained with a pH of 5.5 and above.

- Altitude – should be high.

b) Establishment and Management

Lucerne is established through seeds. The land is cleared, ploughed, and harrowed to a fine tilth. The seeds are inoculated by coating them with Rhizobia. Seeds are broadcasted at the rate of 5-10kg/ha. DSP fertilizer should be applied at the rate of 125kg/ha during planting.

c) Utilization.

Lucerne is fed to livestock as hay since freshly harvested Lucerne causes bloat. It's fed in small quantities mixed with grass hay.

d) Production per unit area

Lucerne produces between 7-11tons DM per hectare with a crude protein of 17-20 %.

9. DESMODIUM.

It's a climbing perennial herb with slender stems and trifoliate leaves. It fixes nitrogen on its own.

There are two varieties of desmodium;

- Silver leaf desmodium (*Desmodium uncinatum*)
- Green leaf desmodium (*Desmodium intortum*)

a) Ecological Requirements.

- Altitude-1200-1800m above sea level
- Rainfall-should be adequate
- Soils-should be well drained

b) Establishment and Management

i) Land preparation

It should be done before the onset of the rains and all the perennial weeds should be removed. The land should be ploughed and harrowed to a fine tilth since the seeds are very tiny.

ii) Planting.

About 1kg of Desmodium seeds are planted per hectare.

iii) Weed Control

Seedbed should be kept weed free. Weeds can be controlled by cultivation, uprooting and use of selective herbicides.

Iv) Fertilizer application.

Phosphatic fertilizers are applied at the rate of 125kg/ha during planting.

d) Utilization.

When harvesting, about 25cm ground cover should be left. It should be cut and wilted before feeding to the livestock. It's used to feed animals in the gestation period because of high crude protein content.

10) AGRO-FORESTRY TREES/BUSHES USED AS FODDER CROPS.

There are several species of shrubs used as fodder crops. They include:

- *Leucaenia*
- *Calliandra*
- *Atriplex*
- *Sesbania*

Shrubs are either intercropped with other crops in the field or incorporated with pasture crops.

a) Ecological Requirements

- *Leucaenia leucocephala* prefers medium altitude and a rainfall of 1500mm p.a.
- *Calliandra calothyrsus* prefers high altitude areas.

b) Establishment and Management

They are established through seeds. Seeds are first raised in nurseries. Seedlings are transplanted at the onset of rains. Weeding should be done. Fertilizers can also be applied.

c) Utilization.

Leaves and branches are cut and given to the animals directly. Cutting should not be done until the shrubs are 3-4m in height. Shrubs are cut back to a height of 0.5m above the ground once per year and at the beginning of the rains. Green

seeds pods produced are removed and fed to animals, as they are very rich in proteins.

Other importances of shrubs

- Improve the soil through nitrogen fixation e.g. leucaena and calliandra
- Their roots hold soil particles together thus controlling soil erosion.
- Their fallen leaves decay adding organic matter into the soil.
- Some provide with wood fuel especially the tree species

d) Production.

Under good management, the shrubs give a considerable herbage yield for the livestock especially the browsers.

FORAGE CONSERVATION

In Kenya, there is always excess forage during the long and short rains (April to June and November to December) and a shortage during the dry months of January to March and September to October. There is therefore the need to conserve the excess forage as its often wasted or not fully utilized.

Reasons for conserving forage.

- To distribute available forage for animals throughout the year.
- To provide feed for the dry season.
- To ensure better and full utilization of available land.
- On a large scale, conserved forage can be sold as hay etc

Methods of conservation

- a) Hay-this is dried forage mainly pasture grasses and legumes e.g. desmodium and Rhodes grass.
- b) Silage-This is an-aerobically fermented forage mainly applicable to succulent fodders such as Napier grass, maize and sorghums.

- c) Standing forage- Growing forage can be set aside for dry season feed and applicable for both pasture and fodders.

A) **HAY MAKING**

Hay refers to forage which has been dehydrated to about 15-20% moisture content. The forage should be cut when about 50% of plants have flowered.

Steps followed in hay making

- i) The crop is cut when about 50% of the plants have flowered
- ii) The crop is spread out evenly on the ground to dry for 2-3 days. It should be dried under controlled conditions in order to retain its nutritive value and the original crop colour.
- iii) The hay is windrowed and the gathered or baled.
- iv) The bales of hay are then stored in a shed out of reach of rainwater and sunshine.

NB/ Rapid drying is recommended to ensure high quality hay. Slow drying results in oxidation of soluble carbohydrates hence poor quality. Prolonged exposure to sun results in the breakdown of chlorophyll and carotene.

Factors determining the quality of hay.

- Forage species used.
- Stage of harvesting hence stem: leaf ratio.
- Length of the drying period
- Weather condition during the drying process
- Condition of the storage structure

B) **SILAGE MAKING**

Silage is a fodder crop harvested while green and kept succulent by partial fermentation in a silo. A silo is the structure used for fermenting. The process of silage making is called ensiling. The objective of ensiling green forage is to preserve the material with minimum loss of nutrients.

Advantages of silage making

- More nutrients are preserved
- It has few field losses

- It is less dependent on weather conditions
- It can be preserved for prolonged periods with minimum loss of nutrients.
- Once ensiled, there are no storage problems.
- It can be fed directly without liquid additives.

Disadvantages of silage making

- Requires skills and much attention.
- Labour intensive hence expensive
- Bulky to store and handle
- Susceptible to ensiling losses
- Must be fed soon after removal
- Most farmers cannot spare sufficient forage for ensiling.

Types of Silos

i) Trench Silo

It is the most popular and applicable to small-scale farmers. It's a rectangular trench on a slightly sloping ground to ensure proper drainage.

ii) Clamp silo

It's constructed above the ground level in form of a trough with slanted sides for ease of compaction. Each side of the silo is made of a pair of timber walls. There is a gap between each pair of timber walls. Soil is put and compacted in these gaps. Between the two pairs of walls is the part where ensiling is done. A clamp may also be made of two stone walls and a cemented floor.

iii) Bunker/Tower silo

A bunker silo is made of concrete under the ground and has vertical walls suitable for mechanical ensiling. A tower is a tall round metallic structure for mechanical ensiling.

Steps followed in silage making

- a) Silo is prepared before harvesting crop. The shape and size of the silo depends on the amount of forage to be ensiled.
- b) The crop is cut at the appropriate stage and wilted for 6-12 hours to about 65-75% moisture content.
- c) The crop is chopped up and put into the silo compacting it every 10-12cm layer.
- d) Silo should be filled as rapidly as possible. The ensiled material should have a 'Ridge' or humped in appearance when ensiling is completed.
- e) Temp in the silo should be checked regularly during the ensiling period. If the temperature is higher than 32.2°C water should be added and compaction reduced. If temperature is below 32.2°C, compaction should be increased and dry materials or molasses added.
- f) The ensiled material is covered with a polythene sheet or a layer of dry grass to protect it from water and air.
- g) The silo is covered with a thick layer of soil maintaining the 'ridge' appearance.
- h) A trench is then dug all round the silo to drain off rainwater.

Principles of Conservation

Rapid ensiling and compaction reduces aerobic respiration in the ensiled material. When the silo is finally sealed, the oxygen is cut off and aerobic respiration gradually gives way to fermentation. This allows lactic acid bacteria (*Lactobacillus spp*) to increase very rapidly within the first three to four days after silo sealing. Lactic acid bacteria act on the readily available carbohydrates to produce lactic acid and some amounts of Acetic, Propionic, Formic and Succinic acids. Lactic acid reduces the pH of forage from 4 to 2 or below. Low pH inhibits further bacterial growth and preserves the silage. The ensiling process is complete in 2-3 weeks depending on

the quantity of ensiled material and may be preserved for many years provided the silo is water and airtight.

USES OF ADDITIVES

Maize and other cereal crops do not need additives if they are harvested at the right stage. (Soft dough stage). Other plants e.g. Napier grass and other grasses have low amounts of carbohydrates and often give poor quality silage. They therefore need additives of,

- a) Crushed grains at a rate of 100kg per ton of silage or
- b) Molasses at 20-40kg per ton of silage evenly distributed at the time of ensiling.

Silage Quality

The relative proportions of organic acids in the silage is an indication of its quality. In good quality silage, the order of predominance should be; lactic, acetic, succinic and formic acids. Poor silage compaction leads to low temperature which results in excessive production of Butyric acid instead of Lactic acid. Good quality silage should be,

- a) Be from high quality forage cut at the proper stage of growth.
- b) Have 5-9% lactic acid
- c) Have a pH of 4.2 or below.
- d) Be free from moulds and bad odour such as ammonia and butyric acid.
- e) Be greenish to yellow in colour not brown or black
- f) Have a fine texture with no sliminess.

Silage losses

- Surface spillage- up to 20% loss due to exposure and contact with soil.
- Seepage losses- extent of this loss increases with increase in herbage moisture. It can be up to 50% in very young and succulent forage.

- Gaseous losses- extended respiration results in loss of carbohydrates in form of carbon dioxide. The silo should be airtight.

How to Calculate Silage Requirement in Dry Matter

A cow requires 3kg of DM for every 100kg of body weight per day.

Therefore a cow weighing 400kg will require $400/100 \times 3 = 12\text{kg}$ of DM per day Since Silage has 40% DM

Then for the cow to have 12kg DM it needs $12/40 \times 100 = 30\text{kg}$ of silage per day.

However, a cow should only get 50% of its daily Dm requirements from the silage.

It should get the other 50% from pastures and other feeds. It should therefore get only 15kg of silage per day.

If the silage is meant for the dry season, the farmer should estimate the length of the dry period. E.g. from January to March there are 90 days.

Therefore, silage required for one cow for 90 days will be;
 $90\text{days} \times 15\text{kg/day} = 1350\text{kg}$ of silage (1.35 tons)

One hectare of Napier produces about 80 tonnes of forage harvested in five cuttings in the year. One cutting therefore yields

$80\text{tons}/5 \text{ cuttings} = 16 \text{ tonnes}$ of forage.

If 1ha produces 16 tonnes of forage

Then x hectares produces 1.35 tonnes of silage

1 ha-----16 tonnes

X ha-----1.35 tonnes

$X = 13.5/16$

= 0.084 hectares (840m²), approximately a space of 30mx30m

Silage density is about 500kg/m³. If a farmer has two cows, the amount needed is

$2\text{cows} \times 15\text{kg} \times 90 \text{ days} = 2700\text{kg}$

The volume of the silo to accommodate 2700kg would be approximately 6m³

The silo would therefore have the following dimensions.

- 2.7m length x 1.5m width x 1.5m depth or
- 3m x 2m x 1m or
- 4m x 1.5m x 1m

C) STANDING FORAGE

This is the cheapest, easiest and most commonly used method of fodder conservation. This implies deferring cutting of the forage for the dry season feed. It however produces herbage of low quality but it can be supplemented by addition of additives. The fodder or the legume should be cut, weeded, and top dressed in early November after which cutting is deferred until it is required.

LIVESTOCK HEALTH III

Introduction.

A disease is any alteration in the state of the animal or its organs which interferes with the proper [performance of its functions. The visible signs of a disease are called symptoms. There are specific conditions that help in observing the disease symptoms. They include:

- Pulse rate and respiration rate
- Temperature
- Body condition
- Visible mucous membranes
- Skin of the animal
- Defecation
- Urination
- Feeding habit. /appetite
- Level of production

Micro-organisms such a protozoa, bacteria, virus and fungi, cause diseases. Poor nutrition, physical injuries, chemical

poisoning and parasite infestation cause other diseases. Organisms such as ticks and tsetse fly only help in spreading disease-causing organisms and are referred to as vectors.

Disease predisposing factors

These are conditions inside or outside the animals' body, which lead to the animal contracting a disease or injury. They include:

- Age of the animal
- Sex of the animal
- Colour of the animal
- Change of climate/environment
- Heredity
- Environment
- Overcrowding
- Physiological conditions such as fatigue, weakness, pregnancy etc.
- Animals encountering sick animals.

Terms used in livestock diseases

1.) Incubation period

It's the duration between the time of infection and the time the first symptoms show up.

2) Mortality

This is the likelihood of death occurring in case of a disease outbreak. It's expressed as a % of the affected animals and those which die.

3) Treatment

It's the application of physical and chemical means to an animal to help it recover from a disease or preventing it from getting a disease. There are two types of treatment.

- Preventive treatment
- Curative treatment

Preventive treatment

This involves administration of drugs to prevent the occurrence of a disease. This can be done through **vaccination** and **administration of prophylactic drugs** such as coccidiostats to prevent coccidiosis. The creation of immunity and resistance to diseases is under the preventive treatment.

Curative treatment

A curative treatment tries to restore a sick animal to good health. This can be done through:

- Good feeding
- Provision of clean environment
- Neutralizing the ill effects of the disease
- Inducing repair to damaged tissues
- Relieving discomfort or injury to the animal
- Preventing further spread of the disease.

4) Immunity

This is the ability of an animal to resist the infection of a disease.

There are two types of immunity –**natural** and **artificial** immunities.

`a) Natural Immunity

It's the ability of an animal to maintain itself free from infection. It's the inborn immunity. It can further be divided into two.

- **Actively acquired immunity.** This immunity is acquired when an animal suffers from a disease. Such an animal is able to defend itself from the same disease in future.

- **Passively acquired immunity**- this is passed through the mothers blood to the foetus or through milk/ colostrums.

-

b) Artificial immunity

It can also be divided into active and passive

CLASSIFICATION OF LIVESTOCK DISEASES

Livestock diseases are classified into four major groups.

- Protozoan diseases
- Bacterial diseases
- Viral diseases
- Nutritional diseases

1. PROTOZOAN DISEASES

Diseases in this category include:

- East coast fever (ECF)
- Anaplasmosis
- Coccidiosis
- Trypanosomiasis (Nagana)

i) East Coast Fever

Animals attacked- mainly cattle

Causal organism-

Theirelia parva- a protozoan transmitted by the brown ear tick (*Rhipicephalus appendiculatus*).

The disease is also called *Theireliosis* its incubation period is 15 days.

Symptoms

- Swollen lymph nodes
- High temp-fever
- Excess salivation
- Lachrimation-a lot of tear production
- Difficulties in breathing due to fluid accumulation in the lungs.

- Coughing
- Sight impairment
- Haemorrhages in the vulva and the mouth.

Control and Treatment

- Ticks should be controlled through dipping, spraying or hand dressing regularly.
- Farm should be fenced to keep out strange animals and also to confine animals within.
- Treatment using appropriate drugs.

ii) Anaplasmosis (Gall sickness)

Animals attacked – cattle, sheep, goats,

Causal organism-

Anaplasma marginale, a protozoan transmitted by the blue tick (*Boophilus decoloratus*)

It can also be transmitted through contaminated surgical equipments, bleeding and hypodermic needles.

The incubation period is 3-4 weeks

Symptoms

- Fever
- Constipation-hard dung
- Paleness in the gums, eyes and lips. An indication of anaemia.
- Milk flow into the udder ceases.

Control and Treatment

- Tick control
- Control of biting insects e.g. mosquitoes
- Injection using antibiotics
- Iron injection.

iii) Coccidiosis

Animals attacked- poultry, calves, young rabbits, kids, lambs.

Causal organism

A protozoan called *Coccidia* of the *Eimeria species*

Each species of the animal is affected by specific coccidia. Coccidia infects the lining of the alimentary canal. Incubation period in poultry is about 7 days but in cattle, it may take up to 4 weeks.

Symptoms

- Diarrhoea
- Dysentery- blood in the dung
- Emaciation
- Ruffled feathers in birds
- Birds become dull with drooping wings
- Sudden death

Control and Treatment

- Use of preventive drugs e.g. *Amprol and Furexol*. These coccidiostats are mixed with feeds or water.
- Isolating infected animals
- Practising hygiene- wet, filthy and unhygienic animal surroundings should be removed
- Cattle from different farms should not drink from a common watering point.
- Overcrowding in poultry houses should be avoided.

iv) Trypanosomiasis (Nagana)

Animals affected- sheep, goats, cattle, pigs and horses.

Causal organism

- a protozoan of the Trypanosome spp transmitted by the tsetse flies.

Incubation period is 1-3 weeks

Symptoms

- Fever
- Animals become dull
- Loss of appetite
- General weakness of the body
- Swollen lymph nodes
- Lachrimation which leads to blindness

- Rough coat
- Swelling of parts of the belly
- Diarrhoea
- Reduced milk production
- Loss of hair at the tail end
- Anaemia
- Abortion may occur in pregnant females due to high temperature.

Control and Treatment

- i) Use of trypanocidal drugs
- ii) Effective control of the tse tse flies
- iii) Confinement of game animals in game parks.

2. BACTERIAL DISEASES

They include the following

- Mastitis
- Foot rot
- Contagious abortion (Brucellosis)
- Scours
- Black quarter
- Anthrax
- Fowl typhoid
- Pneumonia

i) Mastitis

Animals affected- cattle sheep, goats, pigs, camels and horses.

Causal organism-

There are two types of mastitis

- a) Streptococcal mastitis caused by a bacterium called *Streptococcus agalactiae*.
- b) Staphylococcal mastitis caused by *Staphylococcus urens*.

Predisposing factors

- a. Stage of lactation period- animals are likely to suffer from mastitis at the beginning and at the end of the lactation period
- b. Udder attachment- those animals with a large loosely hanging udders and long teats are more susceptible to mastitis infection
- c. Incomplete milking- when milk is left in the teat canal, it acts as a culture medium for bacteria.
- d. Mechanical injuries- wounds on the teats or udder allow micro organisms entry into the udder.
- e. Poor sanitation-
- f. Poor milking techniques- this may result in mechanical injury of the teats and weakening of the sphincter muscles of the teats
- g. Age- older animals are more likely to be infected compared to younger animals.

Symptoms

- Milk contains blood; pus, thick clots or turns watery.
- Udder and teats are swollen
- Animal rejects suckling or milking and also kicks due to pain
- Death of the infected area
- Milk has salty taste

Control and treatment

- a. Infected area of the udder is emptied of milk and an antibiotic is instilled and left for 12 hours
- b. After every milking use teat dip on every quarter
- c. Strict cleanliness and use of disinfectants during milking.
- d. Using the right milking technique
- e. Dry cow therapy- this is the infusion of long acting antibiotics into the teat canal when drying off the cow.

- f. Use of strip cup to detect mastitis. Infected cows should be milked last.
- g. Separate udder clothes should be used for each animal.
- h. Sharp objects should be removed from grazing and milking areas to prevent teat injuries.
- i. Open wounds on the teats should be treated immediately.

ii) Fowl typhoid

Animals affected- poultry

Causal organism

- Bacterium called *Salmonella gallinarum*

Symptoms

- Birds are depressed
- Respiratory distress and birds are dull
- Drooping wings
- Combs and wattles become pale and shrunken due to anaemia.
- Greenish yellow diarrhoea
- Sudden death

Control and Treatment

- a. All infected birds should be killed and properly disposed
- b. Poultry house should be clean, dry and well ventilated.
- c. Regular vaccination
- d. Eggs for hatching and chicks should be obtained from reliable sources.
- e. Sulphur drugs mixed with water or mash are used for treatment.

NB/ *Furazolidone* at the rate of 0.04% in mash for ten days treats the disease effectively.

iii) Foot rot (Foul - in- the - Foot)

Animals affected- all cloven animals e.g. cattle, goats, sheep (most Serious).

Causal organism

- caused by the following bacteria-*Fusiformis necrophorus* and *Fusiformis nodosus*

Predisposing factors

- i) Filthy surroundings e.g. wet and muddy areas.
- ii) Cracking of the hooves due to overgrowth.

Symptoms

- Animals foot become swollen
- Pus and rotten smell come out of the hoof
- Kneeling when grazing if front feet are affected
- Animals spend most of their time lying down when the hind feet are affected
- Emaciation due to lack of feeding.

Control and treatment

- i) Provide clean environment i.e. avoid dampness and muddy conditions
- ii) Practice regular foot examination and hoof trimming
- iii) Practice a regular walk through a copper sulphate (Blue vitriol) footbath at 5-10% solution or Formalin at 2-5% solution.
- iv) Wounds on the feet should be treated with antiseptics
- v) Healthy sheep should be moved to dry clean areas.
- vi) Separate healthy animals from sick ones.

iv) Contagious abortion

Its also called Brucellosis or Bang's disease .

NB/ This is a contagious and infectious disease.

Causal organism

Cattle-*Brucella abortus*.

Pigs- *Brucella suis*.

Goats and sheep- *Brucella malitensis*

Milk from an infected animal should not be drunk.

Symptoms

- i) Abortion or a pre-mature birth of the young
- ii) During later stages of pregnancy if abortion occurs, placenta is retained.
- iii) The cow may become barren while bulls have low libido and have inflamed testes.
- iv) A yellowish brown, slimy, odourless discharge from the vulva may occur after abortion.

Control

- Culling infected animals
- Vaccination against the disease
- The attendant should avoid contaminating his hands with the aborted foetus
- Cleanliness to be observed
- A blood test should be carried out for all the breeding animals in order to detect the infected ones.
- Use of artificial insemination.

NB/ There is no effective treatment.

v) Scours

Animals affected- young one of cattle, pigs, sheep, and goats.

Causal organism-

A bacterium called *Escherichia coli*.

Predisposing causes

- i) Unhygienic conditions in the house of the young ones
- ii) Overfeeding the calf with milk or feeding it with very cold milk
- iii) Lack of colostrums
- iv) Feeding young ones at irregular intervals
- v) Absence of green fodder in the mothers diet which causes lack of vit A

Symptoms

- White or yellowish diarrhoea in calves
- Faeces have a pungent smell
- High temp
- Animal becomes restless
- Loss of appetite
- Sunken eyes
- Undigested milk and mucus with blood spots in faeces
- Sudden death if no treatment

vi) Black quarter

This is an acute disease, which is contagious.

Animals affected- all ruminants

Causal organism

Bacteria called *Clostridium chauvei*, which enters the body through contaminated water and wounds.

Symptoms

- Lameness in animals
- Affected parts of the body become swollen immediately
- High temperature-fever
- The animal breathes heavily and fast
- The animal is dull and losses appetite
- There is grunting and grinding of teeth
- Sudden death
- Blood oozes from the anus and nose
- Animal stops chewing the cud
- If the cut muscles are cut they appear dark

Control

- i) Affected animals may be treated with antibiotics e.g. *penicillin, oxytetracycline and sulphathiazole.*
- ii) Vaccination using black quarter vaccine

- iii) The carcass should be buried deep or burnt completely.

vii) Anthrax

This is an acute infectious and notifiable disease.

Animals affected- cattle, sheep, goats, man, and wild animals.

Causal organism

Bacteria called *Bacillus anthracis*. Animals get anthrax through

- Grazing in infected pastures as the bacteria is found in the soil.
- Bites by insects
- Open wounds
- Bone meal from infected animals.

The bacterium is capable of forming spores outside the animal body.

Symptoms

- Extensive bloating of the stomach after death.
- Fever
- Blood stains in the faeces and milk
- In pigs the throat swells and this may cause death due to suffocation
- Carcasses of an anthrax attack lack *rigor mortis* i.e. the carcass is not stiff as in other animals.
- In the dead animal, a tar-like watery blood comes off the orifices e.g. nose, anus and mouth. Blood does not clot quickly.

Control

- Treatment of wounds.
- Giving large doses of anti-anthrax serum for curative treatment
- The carcass must not be opened
- Vaccination using Blanthax in areas where the disease is prevalent

- Imposing quarantine in case of disease outbreak.
- Dead animal must be disposed off properly by burning or deep burying.

viii) Pneumonia

This is an infectious lung fever.

Animals affected- calves, kid, lambs, piglets and poultry.

Causal organism

Bacterium called *Mycoplasma mycoides*. Dust or worms in the lungs could cause the disease.

Predisposing causes

- Poor ventilation
- Lack of enough oxygen
- Overcrowding
- Age- young animals are more prone to the disease
- Effects of diarrhoea and other illnesses
- Dampness and chilliness.

Symptoms

- i) The animal becomes dull and reluctant to move
- ii) Loss of appetite
- iii) There is a rough hair coat
- iv) Emaciation
- v) Animal breathes rapidly
- vi) Abnormal lung sounds i.e. bubbling
- vii) If the chest is pressed the animal starts coughing
- viii) Fluctuating temperatures
- ix) Nasal mucous discharge.

Control and treatment

- i) Young animals should be kept in warm pens.
- ii) Use of antibiotics
- iii) Isolating the infected animals
- iv) Proper sanitation

3. VIRAL DISEASES

i) Rinderpest

This is a highly contagious and infectious disease. It's notifiable.

Animals affected- cattle, sheep, goats, pigs and wild animals with cloven hoofs.

Causal organism-

Virus

Incubation period- 3-8 days

Symptoms

- High temperature
- Staring coat
- Discharges in the mouth and nose
- Diarrhoea and dysentery
- Mucous membranes of the mouth and nose become red and they develop ulcers.
- Emaciation
- Grinding of the teeth
- Death in 2-10 days after incubation.

Control

- Vaccination annually
- Culling the infected animals
- Notify the authorities in case of an outbreak
- Quarantine in case of the disease
- Separate sick animals from healthy ones.

ii) Foot and Mouth Disease

It is a highly contagious and infectious disease. It is notifiable. Animals affected- cattle sheep, goats, some wild animals.

Causal organism

Virus types A, C, and D

The virus can be transmitted by contaminated litter, feet, garbage and infected saliva.

Symptoms

- Sharp rise in temperature lasting only for a few hours
- Blisters or wounds appear on the mouth and feet.

- The tongue, lips and gums are inflamed. This makes eating difficult
- Lameness due to lesions between the skin and hoof
- There is profuse salivation
- Vesicles may appear on teats and udders
- The animal becomes weak and thin very fast
- There is drop in milk production

Control

- Vaccination every six months
- Quarantine in case of outbreak
- Culling
- Use of disinfectants on wounds.

iii) Newcastle Disease

It's a notifiable disease, very contagious and highly infectious disease.

Animals affected- poultry especially three months to one year.

Causal organism

Virus

Symptoms

- Birds have difficulty in breathing
- Beaks remain wide open and the necks are strained
- The bird is dull
- The bird stands with eyes closed all the time
- Loss of appetite
- Nasal discharges, which force the birds to shake heads to clear.
- Birds stagger in motion
- Watery yellow diarrhoea
- The birds have their beaks and wings down

Control

1. Quarantine
2. Culling

3. Cleaning and disinfecting the houses before bringing in new stock
4. Vaccination during the first six weeks and two to three months later

iv) Fowl pox

Animals affected- all poultry

Causal organism

Virus

Predisposing factors

- Presence of wounds
- Presence of mosquitoes, ticks, lice and other biting insects that spread the disease.

Symptoms

- Lesions on the combs and wattles
- Lesions on legs, vent, feet and under the wings.
- Lose of appetite hence emaciation and death
- Difficulty in breathing and swallowing.
- A watery discharge from the eyes in the early stages of the disease
- The bird become dull

Control

1. Remove all infected birds and kill them
2. Vaccinate remaining healthy birds.

4. NUTRITIONAL DISEASES

i) Milk Fever

This is a non infectious disease.

Animals affected-cows, goats, and pigs that have recently given birth.

Cause

This is due to loss of calcium and phosphorous through milk secretion. There is also an increase in the level of magnesium and sugar in the blood.

Symptoms

- Dullness

- Muscular twitching causing the animal to tremble
- Staggering as the animal moves
- Animal falls down and becomes unconscious
- The animal lies down on its side and the whole body stiffens
- Body functions such as urination, defecation and milk secretion stop.
- Sudden death if the animal is not treated immediately
- Stomach contents are drawn into the mouth
- Complete loss of appetite

Control

i) Treatment

Intravenous injection of soluble calcium salt in form of *calcium borogluconate* 60gms. Dissolved in 500cc of water that is boiled and cooled

ii) Nursing care

The sick animal should be kept in a comfortable position. Fresh water should be given. Mechanical removal of urine speeds up recovery.

Prevention

- Partial milking of cows with past cases of milk fever is done for the first ten days
- Providing sufficient amounts of calcium and phosphorous in the diet
- High doses of vit D and parathyroid extractions

NB/ the animal suffering from milk fever should never be given medicine through the mouth because,

- 1. It will not be able to swallow the medicine*
- 2. The medicine may get into the lungs thereby promoting lung fever speeding up death.*

ii) Bloat

Animals affected- mainly cattle and sheep. Goats may also be affected

Causes

-Accumulation of gases as a result of food fermentation in the rumen. This is caused by:

- Obstruction of the oesophagus due to bulky food particles such as potatoes, carrots etc
- Abnormal pressure exerted on the oesophagus by a swelling in the wall of the chest
- Indigestion caused by accumulation of gases due to paralysis of the rumen and the valve at its entrance. This may be due to the animal eating poisonous herbs or due to sudden change of feeds especially soft green forage, which is taken in large quantities. E.g. Beans, cabbage leaves, lush grass Lucerne etc

Symptoms

- The left side of the abdomen is excessively distended.
- Death may occur within hours due to too much pressure exerted on blood vessels, lungs and heart.

Control

Feed ruminants with dry roughage during the wet season.

Treatment

This involves the release of accumulated gases through.

- **Manual means.** - Exercising the animal and rubbing its abdomen with both hands
- **Surgical means**- this is through piercing the abdominal wall directly over the blown up part of the rumen using trocar and cannula. A stomach pump can also be used to eject the excess gases through the oesophagus.
- **Chemical** –this can be done through,
 1. Drenching of the animal using suitable oils such as turpentine oil mixed with vegetable oil

2. Administering Epsom salt to clear the rumen contents. Drenching does this.
3. Administration of methyl silicone as an injection directly into the rumen. This prevents the frothy type of bloat.

Parturition in Goats (kidding)

Gestation period is 150 days or 143-153 days. Nannies carrying twins kid a few days earlier.

- Put nannies in a dry place under a shade or shelter to prevent kids from wet, cold and exposure to intensive heat that can cause death of kids..
- Keep nanny and another female to avoid nervousness at kidding time.
- Do not disturb the animal.
- Seek for professional help if mulpresentation occurs or kidding delays for 3 hours.
- If placenta is retained, move the goat out with the others for physical exercise. This activates expulsion.

Kidding Signs

- (i) Under firms and teats enlarge.
- (ii) The muscles at either side of the tail slacken or relax.
- (iii) Restlessness; pawing the ground, rise up, lie down frequently.
- (iv) Separate itself from the rest of the flock.
- (v) A clear discharge from the vulva.

Parturition in Pigs (farrowing)

Gestation period is 4 months or 113-117 days.

- Clear and disinfect the farrowing pen.
- Introduce dry warm beddings with a farrowing crate 7-10 days prior to farrowing.

- Drench the pig to control internal parasites.
- Clean the skin with soap and water to remove external parasites, remove oil exudates from their skin which reduce effectiveness of acaricides and to remove mud and dirt.
- Bring the sow to the farrowing pen 3 days to the expected date. This helps the sow to;
 - i) Familiarize herself with the new environment to reduce nervousness.
 - ii) Avoid inconveniences of transferring the piglets in case of early farrowing.
- Ensure the removal of afterbirth to prevent eating it. Sows which eat afterbirth eat piglets too.
- Remove afterbirth from the pen because it decomposes causing infections to the piglets.
- Feed the sow generously and give plenty of clean water.

Farrowing signs

- i) Restlessness.
- ii) Enlargement of vulva.
- iii) Muscles on each side of the tail slacken.
- iv) Loss of appetite.
- v) Udder and teats enlarge.
- vi) Sows collect beddings at one corner to build a nest.
- vii) 24 hours before farrowing, milk is present in the teats.

Management practices carried out to the piglets immediately after birth

- Ensure they are breathing.

- Ensure they are warm or put them in a warm place.
- Ensure they suckle colostrums within 6-12 hours of life.
- Disinfect the naval cord to avoid naval illness.
- Clip the sharp teeth of the piglets to avoid injury to the mother's teats.
- Tail clip to control cannibalism.

Parturition in Rabbits (kindling)

Place a nest box and provide plenty of dry, soft bedding in the hutch from 4th week of gestation.

Kindling signs

- Doe plucks off fur from her belly.
- Uses the fur to build a nest about 3-10 days earlier.
- Goes off feed.

BEE KEEPING (APICULTURE)

Apiculture is the science of keeping bees.

Importance

- a) Production of honey;
 - Has high energy value
 - Is a sweetener for beverage and soft drinks.
 - Is medicinal---Used to dress fresh wounds.
- b) Honey and bees wax are sold to earn income.
- c) Require little capital and land to keep.
- d) Bees are good pollinators for many crops.

Types of Bees

1. African wild bee

Characteristics

- i) Well adapted to local conditions e.g. high temperatures.
- ii) High flying power –Fly for long distances.

- iii)** More active in search of food and water and hive protection.
- iv)** Fairly resistant to diseases e.g. Acarive and American foul brood disease..
- v)** Vicious if manhandled.

2. European Bee

Characteristics

- i) More gentle and larger than African bee.
- ii) Less active and vicious.
- iii) Susceptible to bee diseases.

The Bee Colony

A bee is a social insect that lives in a colony

There are three types of bees in a colony. I.e. the queen, Drone and worker bee.

a) The Queen

One queen in a colony

Functions:

- i) Lay fertile eggs.
- ii) Keeping the colony together by production of a pheromone (queen substance) for identification.

b) The Drone

About 300 in number in a colony.

Functions:

- i) Fertilize the queen.
- ii) Control temperature or cool the hive. i.e. by flapping their wide wings at a very high speed.

N.B The drones are killed by worker bees after fertilizing the queen.

c) The worker bees

-About 60,000 in number in a colony. Smallest and normally female bees.

Functions;

- i) Feed queen, drones, and brood (9 young bees).
- ii) Protect hive from intruders.
- iii) Collect nectar, pollen, tree resins, gums and water.
- iv) Build combs and seal the cracks and crevices in the hive.
- v) Make honey and bee wax.

Life cycle of a bee

1. Fertilized queen move from one cell to another laying an egg in each.
2. Eggs hatch after three days into larvae due to the warmth and temperature generated by the worker bees.
3. Larvae are fed by the nurse bees on special honey. Each larva spins a cocoon and after 2 days moults into a pupa.
4. Pupa become young bees after 10 days and emerges from the cocoon.

Eggs, larvae and pupa form the brood.

Siting the Apiary

Apiary: Is a place where bees are kept.

Factors considered on siting an Apiary:

1. Availability of water: where water is not within 3 km radius, sugar solution or syrup is placed close to the hives.
2. Availability of flowers: To provide nectar and pollen.
3. A sheltered place: e.g. a forest to protect bees from sun and wind.
4. Quiet place: Free from noise and other disturbances.

5. Away from human beings and livestock: i.e. away from homesteads, pastures and busy roads. Bees sting.

5. Away from human beings and livestock: i.e. Away from homesteads, pastures and busy roads. Bees sting.

Types of bee hives

1. Log Hive; Made of log. Log is split into 2-the larger part is made into a trough- shaped structure. The smaller part (floor board) is removed after suspension during harvesting without damaging the combs and brood.

Diagram

2. Box hive: sown timber cut to a length of 1m. Diagram.

3. The Langstroth hive; Like a box hive but separated into chambers for the brood and the honey. To separate brood and honey chambers, a queen excluder is placed between the two chambers. The top board acts as the roof and the bottom board as the floor.

4. Kenya top Bar Hive (KTBH); moveable frame hive. Bees attach their combs on the top bars which can be removed for examination.

Advantages of KTBH

a) Top bar can be removed for inspection of combs and replaced.

b) Honey combs can be removed without damaging the brood.

c) Honey is of high quality since it is harvested without the brood.

d) More wax is harvested as honey combs are not returned to the hive.

e) The hive is easy to construct and repair.

- f) Hive is cheap to build and no expensive equipment is required to extract honey.
- g) A queen excluder is used in the centre of the hive to separate honey from the brood so as to further increase the honey quality.

LIVESTOCK PRODUCTION III (SELECTION AND BREEDING)

Reproduction and reproductive system

Reproduction is the process by which off springs are reproduced. Sexual reproduction involves the union of the female and male gametes. Female gametes and the male gametes fuse to form the zygote. Fertilization takes place in the body of the female. Embryo formed develops inside the body of the mother where its fed and protected until the end of the gestation period.

In poultry, however eggs are fertilized internally but the development of the chicks takes place outside during **incubation**.

Reproduction in cattle

Male reproductive system produces the male gametes called spermatozoa's, which are introduced into the female reproductive system.

The male reproductive system

It's composed of the following:

- Testes
- Epididymis
- Sperm ducts
- Accessory glands (seminal vesicles and the prostate glands)
- Penis

Testes

They produce sperms and they hang outside loosely between the hind legs. Each testis is enclosed in a loose skin called scrotum. Scrotum regulates the temperature of the sperms so that they don't die.

Epididymis

These are coiled tubes that store the sperms

Sperm ducts

They carry sperms to the urethra. Urethra also forms a part of the urinary system. Urethra expels the sperms through the penis. Urine and semen cannot be expelled at the same time due to presence of sphincter muscles which contract allowing either urine or sperms to pass.

Accessory glands

Prostate gland produces some fluid that neutralizes the acidic effects of the urine in the urethra hence preventing the death of the sperms. Seminal vesicles produce clear sticky fluid called semen. Semen carries the sperms out of the penis in fluid form. One ejaculation of sperms has many sperms but only one is required for fertilization

Penis

In bull, its long and muscular structure carried on the underside. It's surrounded by a sheath which is an extension of the skin. Penis introduces sperms into the vagina of the cow during mating. At the time of mating the penis protrudes outside the sheath.

Female Reproductive system

It's composed of:

- Ovaries
- Fallopian tubes

- Uterus
- Vagina and vulva

Ovaries

Are two located in the abdominal cavity near the kidneys, one on the right and one on the left... ovaries produce ova which is the female gamete. They also produce the female hormones. A hormone oestrogen is produced under the influence of another hormone called Follicle stimulating hormone (FSH). Oestrogen is produced by the Graafian follicle located in the ovary.

Oestrogen induces Oestrus which is the heat period so that the cow shows signs of heat. After every 21 days, the ovary releases a mature ovum and the cow comes on heat.

Fallopian Tubes (oviduct)

Ovum travels through the fallopian tubes to the uterus. The release and movement of the ovum down to the uterus is called ovulation. If mating is done at this time fertilization occurs.

Uterus

This is where fertilization takes place. The fertilized egg implants itself on to the walls of the uterus and develops into the foetus.

Vagina and Vulva

Vulva is the external opening of the cow's reproductive system. It allows mating to take place so that the sperms are deposited into the vagina. The vagina acts as the birth canal-

Pregnancy/Gestation Period

This is the normal period between fertilization and the expulsion of the foetus through the vulva. The gestation period varies with different animals.e.g

Animal	Length in days
Cow	270-285
Sow	113-117
Ewe/Goat	150
Rabbit	28-31

During pregnancy a hormone called progesterone is produced by the placenta to maintain pregnancy. After birth, the reproductive tract undergoes a period of healing (Rest) during which it's repaired and returns to normal.

Parturition/Birth

This is the act of giving birth. This is the time when the foetus is expelled through the birth canal. The following signs are expressed by a cow that is about to give birth.

1. Distended udder which produces a thick milky fluid (Colostrums)
2. Swollen vulva producing a thick mucus like discharge
3. General restlessness
4. Loose and slackened pelvic girdle
5. Visible pin bones
6. A water bag appears and bursts just before calving

After these signs are seen the animal parturates normally within 2-3 hours. The correct presentation is with the front feet first and the head resting between the feet. Any other presentation is called **Malpresentation or Breech**

Presentation especially when the hind legs come out first.

Reproduction in Poultry

The cock has no penis but a small opening near the vent through which sperms are emitted. It has testis within its body. Hens have an elongated oviduct necessary for the

formation of the egg. Fertilization takes place internally. During mating the hens cloaca (vent) protrudes so that the vent of the cock fits into it. The vent of a hen sucks the sperms which flow to the uterus through the oviduct of a hen.

Reproductive system of the hen consists of the following.

1. Ovary
2. Funnel (infundibulum)
3. Magnum
4. Uterus
5. Vagina
6. Cloaca

Ovary

A hen has two ovaries and only the left one is functional. Eggs or ova are formed in the ovary. A hen has 3,500-4,000 ova. Each ovum is contained in a follicle. When the ovum or yolk is mature, its released from the ovary by the rupture of the follicle. It moves into the oviduct where its received by the funnel.

Funnel

Its 11.6cm long and fertilization takes place here.

Chalazae are added to hold the yolk

Ovum stays here for about $\frac{1}{4}$ hour

Magnum

It's 33cm long. Yolk moves down the magnum where thick albumen is added. It stays here for 3 hours.

Isthmus

It's 10.6 cm long. Shell membranes are added. Water mineral salts and vitamins are also added. The egg takes about $\frac{1}{4}$ hour to move from this region.

Uterus (shell gland)

The region has calcium deposits

Shell is added round the egg

Egg stays here for about 18-22

Vagina (6.9 cm)

Egg is temporarily stored before it's laid

Cloaca

The egg moves out of the cloaca through the vent. Cloaca extends out to prevent the egg from breaking.

NB/ whether fertilization takes place or not the egg will have to be formed. Fertilization doesn't take place the egg cannot hatch. The process of egg formation in a hen takes about 24-26 hours. Therefore, a hen is able to lay only one egg in a day. The components of an egg are obtained from the body reserves of a hen.

SELECTION

Selection is a process of allowing certain animals to be the parents of the future generations while culling others. The animals retained in the herd have certain desirable characteristics which make them produce more. The selected animals males and females make up the *Breeding stock*. Breeding stock is used to produce offspring's with the same qualities or better than their parents. Breeding stock should therefore pass the good traits of quality to their offspring for better performance thus improving the livestock. Selection process repeated for many generations increases the *Gene Frequency* i.e. occurrence of the genes that carry desirable characteristics. Selection therefore increases the occurrences of desirable genes and reduces the undesirable genes.

Heritability

This refers to the likelihood of a particular trait to be transmitted to the offspring. E.g. in dairy cattle the characteristics which are highly heritable include butter fat content, growth rate, and mortality rate at birth.

A character like milk yield is lowly heritable. Such a character is environmental i.e. weakly inherited and selection will not improve it. The degree to which selection affects a character depends on the following factors;

1. heritability of the character
2. intensity within which selection is done
3. interval between generations and kind of selection being practiced

Factors to Consider When Selecting a Breeding Stock

1. **Age** - young animals should be selected because such animals have a longer productive life. Very old animals are low producers and poor breeders.
2. **Level of performance** - only animals with the highest production level should be selected.. Performance is best determined by use of records. Performance of the relatives such as ancestors should be checked to ascertain whether the animal belongs to a high producing family. The ability of the parents to pass good qualities to their offspring's is referred to as **prepotency**.
3. **Physical fitness** – animals selected should be free from any physical defects such as limping, irregular number of teats, mono eyed and weak back line etc.
4. **Health** – Animals selected should be healthy. Sick animals do not breed well and those falling sick often are expensive to keep.
5. **Body conformation** - Animals for breeding should be selected according to their proper body conformation. E.g. Dairy cows should be wedge shaped with a large udder

6. **Animal behaviour/ Temperament** – Animals with undesirable behaviours e.g. cannibalism in poultry and aggressiveness in dairy cattle should be culled.
7. **Quality of Products** – animals that give products of high quality should be selected. E.g. in wool production breeds that produce fine, long elastic and pure white wool should be selected.
8. **Mothering ability** – Animals selected should have a natural instinct towards their young ones. This enables them to rear the young ones up to weaning.
9. **Adaptability** – Animals selected should be well adapted to the prevailing climatic conditions in the area.
10. **Prolificacy** – Animals selected should be highly prolific. i.e. have the ability to give birth to many off springs at a time.

Methods of Selection

•Mass selection

This is the choosing of animals for breeding on the basis of their own performance and the mating them at random. Offsprings of these animals are expected to show higher performance than the previous herd. This is because mass selection increases the occurrence of the desirable genes in a population.

•Progeny testing

Progeny is the offspring resulting from selected parents. In this method a group of progenies are used to as an aid to increase the accuracy in the selection of the breeding stock.

It's used when the character is expressed by one sex only.

Progeny testing takes a long time for the results to be realized.

E.g. it may take a bull 8-9 years before the progeny testing results are out.

•Contemporary comparison

This method involves the comparison of the average production of the daughters of each bull with that of the other heifer referred to as **Contemporaries** in the herd. The method assumes that the differences between the herds of the same breed are non-genetic in origin.

Advantages

- It's possible to compare animals of different age groups
- Accurate due to presence of comparison
- Eliminates differences brought about by environment since average performance of the herd is used.
- It's possible to make direct comparison of the bulls at different A.I Centers.

BREEDING

Selection increases the gene frequency and ensures that the desirable genes are concentrated in the offspring thus performing better than the parents. Selection therefore doesn't introduce or create new genes in an animal but uses the existing ones.

Breeding is the process of mating selected females and males to produce offsprings of the required characteristics.

Reasons for Breeding

1. to expand the inherited potential of the animal
2. To introduce new genes to improve animals productivity.
3. To produce animals those are resistant to diseases and other environmental hazards.
4. To satisfy consumers taste e.g. tender meat, fast growth rate etc.
5. Economic reasons; breeding animals with high growth rate means that these animals acquire market weight very fast.

NB/ Genetic factors play a big role and therefore proper methods should be adopted. These genetic factors include;

Inheritance

This is the genetic transmission of traits from the parents to the offsprings. These traits are carried by the male and female gametes. An animal's body has two types of cells, **sex cells called the gametes and the somatic cells called the body cells**. Sex cells have chromosomes that contain genes.

Chromosomes

They carry gene which determine the specific characteristics in an individual animal. They exist in pairs in the nucleus of the body cells and are always constant in number. In the sex cells the genes are found in single units. i.e.

Animal	No. of x-somes in body cell	No. of x-somes in sex cells
Cow	60	30
Sheep	54	27
Chicken	78	39
Pig	38	19

Genes

These are very tiny units of inheritance carrying particular traits found in animals e.g. Body shape, disease resistance, prolificacy, colour etc. they are found in specific points in chromosomes called the gene loci (locus). They look like beads on a string.

Diagram

Genes occurs in pairs on the chromosome called alleles. Alleles form *allelomorphic genes*. If the members of an allele have the

same effect or quality, the character is said to be homozygous. If these genes have different effect that carries different qualities the resulting character will be heterozygous.

Cell Division

The two types in animal multiply themselves through the process of cell division.

Body cells – *somatic cells* divide by a process called *mitosis*. In mitosis each parent cell produces two daughter cells having the same number of chromosomes as the parent cell.

Sex cells- gametes divide and reproduce through a process called *meiosis*. The process results in four daughter cells having half the number of chromosomes as was in the parent cells.

During fertilization when the sperm joins with the ovum (each having half the number of chromosomes), the full chromosome number is restored.

Terms used in Breeding

Dominant and Recessive Traits

Dominant means to suppress the other. Recessive means suppressed or dominated by the other characters. If the dominant and the recessive traits are brought together, the offspring shows the dominant trait e.g. the gene for horns is dominant over the gene for hornless. Therefore if a polled bull (hornless) is mated with a horned cow, the offspring produced will be horned.

Sometimes there is partial dominance (incomplete dominance) where the offspring do not resemble either parent exactly.

Hybrid and Hybrid Vigor

An animal is a hybrid if it possesses a dominant characteristic and the other one is recessive. If two hybrids are crossed, the offsprings will attain 75% dominance and 25% recessive ness. If two superior animals of different breeds are mated, the offspring that results is highly productive and has a higher growth rate and an improved body conformation. Such an animal has hybrid vigor or *heterosis*. Hybrid vigor is increased vigor and performance resulting from crossing two unrelated *superior animals*. The genes that produce vigor are dominant are while those that lack vigor are recessive.

Epistasis

It's the combination of genes which individually could have been undesirable or inferior. This way, the effects of some recessive genes are masked such that they cannot be expressed.

Breeding Systems

- Inbreeding
- Out breeding

1. Inbreeding

This is the mating of animals which are closely related to each other.

Reasons for Inbreeding

1. To increase the genetic uniformity in a herd – increasing homozygosity.
2. Fixing required characteristics in the new breeds.
3. Increasing phenotypic uniformity. This helps to describe the external characteristics of a certain breed for example the colour of Friesians is black.
4. Used to test whether an animal has high prepotency.

5. To get proven sires i.e. males which have been confirmed and proven to have high qualities through backcrossing.

Disadvantages

1. loss of hybrid vigor
2. high rate of pre-natal mortality
3. may lead to decline in fertility hence species extinction

Systems of Inbreeding

- a) Close Breeding: this is the breeding of very closely related animals. i.e. sib mating- between brothers and sisters and parent-sib mating – between parents and offsprings.
- b) Line Breeding- this is the mating of distantly related animals that share a common ancestor. E.g. Cousins and cousins, granddaughters versus grand sires etc. the system aims at preserving good qualities of superior ancestors.

2) Out Breeding

This is the mating of animals that are not related.

Reasons for Out Breeding

- a) To introduce new desirable genes
- b) To exploit heterosis (hybrid vigor). A cross breed performs better than the average of the two parents
- c) To establish a new breed or a grade animal.

Systems of Out Breeding

- Out crossing
- Cross breeding
- Upgrading (grading up)

Out Crossing

This is the mating of unrelated animals but within the same breed e.g. serving a Friesian cow in Nakuru with semen from a Friesian bull in Britain. The system helps to overcome weaknesses obtained through inbreeding. It also maintains the characteristics of a pure breed such as colour.

Cross Breeding

This is the mating of two animals from two different breeds. This creates hybrid vigor. The system helps to upgrade the local animals by crossing them with exotic ones especially for better milk production.

Upgrading or grading up

This is where the female of low grade stock is mated with a pure bred sire. The offspring gets half of the sire's genes. Such an offspring is referred to as a *Hygrade*. The system is commonly used in A.I to improve local cattle for milk production.

Mating in Livestock

a) Mating in Cattle

Oestrus (Heat Period)

A cow comes on heat every 21 days. The duration between one heat period and the next is called oestrus cycle. Heat period in a cow lasts for 18-30 hours. The cow should be taken for service 12-18 hours after showing the first heat signs for successful mating.

Signs of Heat

- Restlessness
- Mounting others and stands still when mounted on
- Rise in body temperature
- Milk yield drops slightly
- Vulva swells and reddens
- Clear slimy mucus from the vagina
- Bellowing and mooing frequently.

b) Mating in Pigs

Sows stay on heat for 2-3 days. The best time to serve is the second day of the heat period. The sow is taken to the boar and allowed to stay there for at least 2 days.

Signs of Heat

- Restlessness
- Frequent urination
- Swelling and reddening of the vulva
- Clear slimy mucus discharge from the vagina
- Frequent mounting on others
- Responds positively to the riding test

c) Mating in Rabbits.

The does are ready for mating at 6-7 months of age. Heat signs are repeated after 14 days.

Signs of heat

- Restlessness
- Frequent urination
- Swollen vulva
- Doe throws itself on its sides
- Doe tries to contact other rabbits in the next hutch by peeping
- The doe rubs itself against the wall or any solid object.

Methods of service in Livestock

- Natural mating
- Artificial Insemination (A.I)
- Embryo transplant

1. Natural Mating

This is the use of a male to serve a female. It is commonly practiced in sheep, pigs, goats and poultry. It can also be used in cattle but AI is now commonly used.

Advantages

- More accurate. The male can detect when the female is on heat.
- Less laborious. There is no need of checking the animals for heat signs.
- Useful when the heat periods of females cannot be easily detect.

Disadvantages

- Transmission of breeding diseases. E.g. brucellosis and trichomoniasis.
- There is a high chance of inbreeding
- Males will need extra pasture to eat that would have been used by the females.
- Large males can injure small females
- A lot of semen is wasted since a single ejaculation produces semen that can serve several females.
- It's cumbersome and expensive to transport a bull from to serve cows. Bulls moved from one area to another may not perform efficiently due to new environmental conditions. cannot

2. Artificial Insemination (A.I)

This is the introduction of semen into the female's reproductive system by hand using syringes or tube.

Semen is collected from a bull using an artificial vagina and a *teaser cow*. Semen collected is then diluted and used to inseminate many cows. Diluted semen is stored in deep frozen state in liquid nitrogen at -1930C.

Special plastic straws called *Payets* are used to store semen for one insemination. Payets may have different colors indicating the breed for different bulls.

Collection of Semen

A teaser cow is restrained in a crush. A bull is brought to the teaser cow. When the bull mounts on the cow and directs the penis to the vulva, a person grabs the penis and directs it into an artificial vagina. Since there is warm water all around the artificial vagina, the bull will ejaculate and the semen is collected.

Advantages of A.I

- i) Semen from one superior bull can be used to serve many cows.
- ii) It controls the spread of and transmission of breeding diseases and parasites.
- iii) Sires that are too heavy and that could injure cows only produce semen to serve the cows.
- iv) Easy to control breeding i.e. one can time when to breed his animals.
- v) It is easy to control inbreeding.
- vi) Reduces the expenses of keeping a bull on pastures and also on drugs.
- vii) Small scale farmers who cannot afford to buy a superior bull can have the cows served at a low cost.
- viii) It eliminates dangerous and aggressive bulls on the farm
- ix) It is easy to transport semen from one place to another.
- x) It is a useful research tool as it helps to study a very large number of offsprings from a single sire.

Disadvantages

- i) Harmful characteristics can be spread quickly by one bull to all the offsprings the bull sires.
- ii) Skilled labour is required
- iii) Requires more human labour than the natural method

- iv) Low chances of conception because semen can die due to storage problems and also due to wrong timing of the heat period.

3. Embryo Transplant

In this method eggs (ova) are harvested from a high quality female, fertilized in tubes and the embryos that develop are transplanted into foster mothers. The female animal that produces the ova is referred to as *donor*. The one that receives is called the *recipient*. The donor female is injected with hormones to stimulate production off more than the normal rate at ago. On superior female can produce many offsprings using this method.

NB. / Whereas A.I increases the number of offsprings sired by one bull, Embryo transplant increases the number of offsprings produced by one female.

Advantages of Embryo Transplant

- Possible to implant embryo from a high quality female to a less superior female and obtain a high performing offspring.
- Stimulates milk production in females that were not ready to produce milk.
- A highly productive female can be spread over a large area to benefit many farmers.
- It is easier to transport embryos in test tubes than the whole animal.
- Embryos can be stored for long periods awaiting availability of a recipient female.

Disadvantages

- Technology is expensive
- Requires trained personnel to handle

- Requires special equipment for fertilization and storage of the embryos.

Signs of parturition in:

- *Cattle (270-285 days)*
- *Pigs (4 months- 3months, 3 weeks, 3 days.)*
 1. *Restlessness*
 2. *Vulva reddens and swells*
 3. *Udder becomes full with a milky fluid*
 4. *Sow builds a nest by collecting some bedding at the corner of the pen.*

Under normal circumstances, farrowing takes place within 4-6 hours of showing the above signs.

- *Rabbits/doe (29-33 days)*
 1. *The doe starts building a nest by plucking off hair from her belly*
 2. *Lack of appetite i.e. no feeding.*

Parturition in rabbits is called *Kindling*.

FISH FARMING (AQUACULTURE)

- This is the artificial rearing of fish in ponds.

Importance of fish farming

1. Cheap and good source of proteins.
2. Can be practiced on limited land.
3. Make fish available nearby when reared in ponds.
4. Source of income to fish farmers.

Species of fish farmed in Kenya

1. Fresh warm water fish(18⁰c of water) e.g. tilapia, carps, black bass, striped bass, cat fish, blue gill, Nile perch etc.
2. Fresh cold water fish (10-15⁰c water) such as trout.

Requirements for fish farming

- i) Water supply – should be free flowing to ensure oxygen supply.
- ii) Slope of land – gentle slope is suitable. In flat land there is no free flow of water.
- iii) Soil – clay soil is best as it does not allow seepage.

Soil test procedure

Procedure A

- i) Take a handful of wet soil.
- ii) Knead in between fingers and roll into a ribbon.
- iii) Throw it into the air and catch it.
- iv) If the ribbon does not break, it is truly clay.

Procedure B

- Dig a hole 1m deep by 30cm wide.
- Fill it with water in the evening and leave overnight, and then fill again in the morning.
- Good soil should retain water up to the evening of the second day.

Establishing a fish pond

Procedure

- i) *Site selection*: should meet the following;
 - a) Topography ie a place where water flows gently from the source.
 - b) Soil should be clay
 - c) Water should be available.
 - d) Security.
- ii) *Site marking*: use pegs to mark the channel from the river, the entrance and exit and channel to take water back to the river.
- iii) *Clearing the land*.
- iv) *Digging the pond*: dig up soil. Topsoil is separated from the other. Upper side is 0.5m deep and lower side is 1.5m deep.

v) *Construct the dyke.* This is a wall constructed round the pond.

vi) *Construct the fence round the pond.*

Constructing the Inlet, outlet and spillway

- *Inlet:* This canal or pipe at the entrance of the pond to bring in fresh water. It should be fitted with a screen to prevent entrance of undesirable fish species.
- *Outlet:* it is made at the deeper end of the pond. A screen is fitted at the mouth of the outlet to prevent fish swimming away.
- *Spillway:* this is channel to remove excess water back to the river. It is made at the top of the dyke at the lower side of the pond. It prevents water from overflowing on the dykes.

NB//

- Grass is planted on the dyke and land around it to stabilize the ground. This prevents dyke erosion.
- The pond is fenced to keep off predators and unauthorized persons.

Stocking the Pond

- Introduce fingerlings (young-fish) from hatcheries e.g. Sagana, Kiganjo, Kisumu fisheries, Bamburi etc.
- Transport them in oxygenated polythene bags, milk cans or drums.
- Provide clean water in the containers at 10 °C temperature.
- Take care not to injure the fingerlings.
- Ensure proper stocking space i.e. 5-10 fingerlings per 5m².

Feeding Fish

a) They feed On planktons

- b) Ground nut cake, kitchen waste, slaughter house waste, leaves, grass and chicken manure.
- They should be given enough food. Excess foods pollute and rot the pond.
- Change of food should be gradual.
- Manure and fertilizer should be added to encourage growth of planktons.

Cropping and Harvesting of Fish

Cropping

This is the removal of marketable size of fish from the pond.

Methods used to catch fish

- a) Baskets
- b) Spears.
- c) Hook and line.
- d) Nets.
- e) Draining

Advantages of using seine nets over hook and line

- a) Only marketable sizes of fish are caught.
- b) Fish are not injured in the mouth.
- c) Ensure large number of fish is cropped.

Harvesting

- This is the removal of all the fish from the pond by draining the pond.

Procedure

- a) The inlet is closed stopping water inflow.
- b) Normal cropping is done using a sine net to remove all large fish.
- c) Outlet is opened to allow water to flow out.
- d) A scoop net is used to catch the fingerlings which are kept in holding pond.
- e) Water is completely drained for the pond to dry up.

Maintenance of the pond

- i) Repairing the dyke or any structure on it.

- ii) Cleaning the pond and remove foreign materials.
- iii) Plant grass where necessary.
- iv) Remove undesirable vegetation.
- v) Remove silt.
- vi) Restock after 2-4 weeks by returning the fingerlings to the pond using a scoop net.
- vii) Control predators.

Fish Preservation

Practices carried out on fish before preservation

- i) Clean the fish to remove mud and worms.
- ii) Remove scales and slime.
- iii) Open the fish to remove the gut and intestines (gutting).
- iv) Clean the abdominal cavity thoroughly.
- v) Keep fish in open containers.

Preservation methods

- i) Freezing using deep freezers.
- ii) Salting; use of salt solution or salt is rubbed.
- iii) Sun drying: fish are spread on a mat and exposed to strong sunlight.
- iv) Smoking: they are subjected to a temperature of 70°C in a smoking pit/house where wood is used as fuel.

NB//

- Fish are transported to the market in refrigerated containers to prevent rotting.
- Fish are exported or sold locally.

Appropriate Handling of Livestock During Routine Management

- i) Carefully avoid inflicting pain on the animals e.g. avoid physical beating.
- ii) Use of structures when handling animals e.g. crushes, head yoke etc.

- iii) Use tools for handling e.g. ropes, halters, lead-stick and bull rings appropriately.
- iv) Use correct method of securing and casting the animal
- v) Use little force when casting animals to prevent bone fracturing.
- vi) Administer drugs safely e.g. by mixing them with food and water e.g. coccidiostats.
- vii) Drench carefully for example do not raise the head too high as this could choke the animal.
- viii) Test equipment for giving the drug to ensure they are working such as the drenching and bolus gun.
- ix) When injecting, sterilize the equipment or use fresh needles per animal to avoid infection.
- x) When spraying, spray in open air during a wind free day to avoid wind drift to unintended places or animals inhaling the chemical.

NB//

- Remove dead animals or carcasses from the herd or flock and dispose off properly through burning and disinfect the area in contact with the carcass properly.

Weeds and Weed Control

A weed: Any plant growing where it is not required and whose economic disadvantages outweigh the advantages.

It is a plant out of place. Or a crop that volunteers to grow without having been planted (self setter).

Noxious weeds: Dangerous weeds whose cultivation is prohibited by law e.g. bhang.

Weeds Identification and classification

Identification

Common name
name

Vernacular

Botanical

Classification

Basis:

- Growth cycle.
- Plant morphology.
- Habitat.

Growth cycle

a) Annual weeds: Complete their life cycle in the field within a period of one year or less e.g. Mexican marigold, Black jack, Pig weed, etc.

Annual weeds are easily controlled especially before flowering.

b) Biennial weeds: Complete their life cycle in two years.

Achieve vegetative growth in the first year and produce seeds in the second year e.g. American wild carrot, spear thistle, ragwort etc.

c) Perennial weeds: **Take** more than two years or seasons to complete their life cycle. Include: Sedges, Lantana, kikuyu grass, Wandering jew, couch grass, Sodom apple. Etc.

Plant Morphology

a) Narrow Leaved weeds: Are grass weeds e.g. Couch, Spear, Setaria, eleusine etc. Grass weeds may be perennial or annual.

b) **Broad Leaved weeds:** E.g. Black Jack, Oxalis, Lantana, Pig weeds, Devil's horse whip etc. May be annual or perennial.

Competitive Ability of Weeds

Factors Contributing to competitive ability of weeds:

a) Produce large quantities of seeds.

b) Remain viable in the soil for a long time awaiting conducive germination conditions.

c) Some weed seeds are easily and successfully dispersed e.g. Fleabane (*Conyza* spp) has developed structures used in wind dispersal.

- d)** Ability to propagate vegetatively e.g. Couch grass and Wandering Jew.
- e)** Elaborate and extensive rooting system.
- f)** Ability to survive where there is limited nutrient supply.
- g)** Short life cycle i.e. can complete their life cycle with restricted rain regime.

Harmful Effects of weeds

- a) Compete with crops for nutrients, space, light, soil moisture therefore reduce crop yields.
- b) Parasitic to cultivated crops e.g. witch weed (striga).
- c) Lower the quality of agricultural produce e.g. Mexican marigold—gives an undesirable flavor to milk when dairy cows feed on it. Devil’s horse whip, black Jack, Forget-me-not, bristly fox toilet get attached to sheep wool thus lowering its quality.
- d) Some weeds are poisonous to man and livestock. E.g. Thorn apple ,Sodom apple (when unripe)
- e) Some act as alternate hosts for insect pests and others for diseases e.g. Black jack for Aphids, Subukia weed, Mallow, flower of the hour etc hosts cotton strainers. Oxalis, wild oats alternate rusts disease.
- f) Allelopathic: Produce poisonous substances that suppress the growth or germination of cultivated plants they contact e.g. Couch grass is allelopathic to Maize.
- g) Block irrigation channels i.e. make it difficult for water to flow freely in irrigated land.
- h) Affect fishing e.g. Salvinia and water hyacinth by blocking navigation and depriving fish and aquatic animals of oxygen dissolved in water.
- i) Lower quality of pastures e.g. tick berry suppress pasture undergrowth. Nut grass and Manyata grass reduce palatability of herbage and carrying capacity of pasture fields.

- j) Irritate workers thus reducing their efficiency e.g. Double thorn, stinging nettle, devil's horse whip etc.

Benefits of weeds to farmers

- a) Edible to both man and livestock e.g. pig weed, wandering Jew, grass weeds etc.
- b) Medicinal effects e.g. Sodom apple, stinging nettle, sow thistle.etc.
- c) Act as soil cover, preventing soil capping due to impact of rain drops.(development of an impervious layer on the soil surface)
- d) Add organic matter to the soil on decomposition.
- e) Leguminous weeds add nitrogen in the soil.

Weed Control Methods

Dictated by –weather condition, type of weed, capital available and effects on the environment.

Include;

- a) Mechanical weed control.
- b) Cultural weed control.
- c) Biological weed control.
- d) Legislative weed control.
- e) Chemical weed control.

1. Mechanical weed control

Involves:

i)Tillage(cultivation)

- Desiccate the weeds by exposing the roots to the air.
- Buries weeds thus killing them.
- Hand tools or tractor implements are used.
- Done during dry season to ensure better drying of weeds.
- Weeds are destroyed before they produce seeds to break their life cycle.

Advantages of tillage in weed control

- Cheap and therefore good for small scale farmers.
- Allow infiltration of water thus minimize soil erosion.

- Earthing up is done during tillage which encourages root growth.
- Crop residue is incorporated in the soil during tillage.

Disadvantages

- Pulverizes the soil thus destroying soil structure.
- Creates suitable conditions for weeds to germinate.
- Laborious and expensive in large scale.
- Leads to water loss, soil erosion and damage to crop roots.
- Does not effectively control perennial weeds.

ii) Slashing (mowing): Is the mechanical removal of shoots from weeds especially annual weeds when done repeatedly.

iii) Uprooting: Done where weeds are scattered or where crops are too close to allow mechanical cultivation.

2. Cultural weed control

Are crop husbandry practices carried out on the farm without use of chemicals.

Include:

i) **Mulching:** smothers weeds thus preventing weed growth.

ii) **Cover cropping;** Smother the weeds.

iii) **Crop rotation:** Weeds associated with certain crops will not germinate or grow when rotated e.g. striga in cereal crops and sugar cane.

iv) **Use of clean planting materials:** Prevent introduction of weeds into the farm.

v) **Proper spacing:** Creates little space for weed growth or form a canopy which suppresses weeds.

vi) **Clean seed bed:** Starts off crops on clean bed to effectively compete with weeds.

vii) **Flooding:** Discourages growth of all non aquatic weeds.

3. Biological weed control:

Is the use of living organisms to control weeds.

Include:

- i) Use of livestock: e.g. goats in coconut and cashew nut plantations.
- ii) Use of certain weed eating fish to control aquatic weeds.
- iii) Use of Moths to control cacti.
- iv) Beetles to control water hyacinth.

Advantages

- Cheap.
- Not poisonous or pollute the environment.
- Less laborious.
- Does not kill soil micro-organisms.
- Does not destroy soil structure.

4. Legislative weed control:

-Involves government laws and acts which prevent the introduction of noxious weeds in a country or the spreading of certain weeds from one part of the country to another.

Imported materials such as seeds, food and clothes are tested to certify they are weed free.

Limitations:

- Enforcement of laws is difficult.
- Only sample of materials are checked while the bulk of the material may have some weeds.

Noxious weed law; requires noxious weeds to be destroyed or not cultivated e.g. bhang (cannabis sativa).

5. Chemical weed control:

Herbicides are the chemicals used to control weeds.

Ways in which herbicides work to kill the weeds.

a) Inhibition of nitrogen metabolism: some interfere with nucleic acids (D.N.A, R.N.A) e.g. Atrazines which increase or reduce nitrogen metabolism. Glyphosate interfere with enzyme functions.

b) Kill the cell: The herbicides penetrate the cell wall, destroy it and enter cell cytoplasm, killing the cell e.g. Diquate, dinosel and oils. These are contact herbicides.

- c) **Causing abnormal tissue development:** Include twisting, gall formation. Some herbicides interfere with plant growth e.g. phenoxy acetic acids, benzoic acids, 2, 4-D and M.C.P.A.
- d) **Inhibiting photosynthesis:** Some herbicides interfere with chlorophyll formation e.g. Atrazines, Simazines, Duron, Linuron, and Uracils.
- e) **Inhibiting Respiration:** some herbicides block movement of materials from the site of manufacture to other areas. They therefore cause acute poisoning e.g. Dinozebs.

Classification of herbicides

Include:

- **Formulation**
- **Time of application.**
- **Mode of action**
- **Environmental factors.**
- **Selectivity.**

i) Formulation

Is the physical form of herbicides e.g.

- **Liquids:** are soluble in water or oils. Are highly concentrated or toxic e.g. dalapon, paraquat.
- **Wettable powders:** Finely ground particles. Form suspensions with water before application. A spreader is applied in the suspension to prevent flocculation. Constant agitation of the particles also avoids clustering. Include: atrazines, simazines and duron.
- **Granules:** Granule form. Control water weeds e.g. duron.

ii) **Time of application:** when applied at different stages of weed growth, herbicides are effective. Include:

- **Pre-emergence herbicides:** Are applied soon after crop seeds have been sown but before they emerge. Kill the

germinated weeds such that crops germinate in a weed-free environment. Include: atrazines and simazines.

- **Post-emergence Herbicides: Are** applied after crop germination or transplantation or at different stages of crop growth. Include; 2,4-D, M.C.P.A, paraquat, Glyphosate etc.

iii) **Mode of Action:**

Include:

- **Contact Herbicides: Kill** only the parts of the plant with which it comes into contact.
- **Translocated Herbicides/Systemic: Kill** the whole plant even if it comes into contact with only a small part of it i.e. they are absorbed into the plant and translocated to all parts of the plant.

iv) **Environmental factors:** Affect effectiveness of herbicides.

Include:

- **Wind:** blow away splash wash to unintended places while decreasing chemical concentration to the intended places.
- **Rain:** Dilute or wash away the chemical to non-toxic levels. Leaches and reach herbicides to roots of deep rooted plants thus killing them.
- **Soil:** some absorb and retain more herbicides than others and therefore require more doses to be effective.
- **Light:** Increase in light intensity increases the rate of light of light absorption and photosynthesis by plants hence increasing absorption and translocation of herbicides and therefore causing faster killing of plants. Some herbicides are decomposed by high light intensity hence become less effective.
- **Temperature:** increase translocation hence absorption of more herbicides and therefore death of plants.

v) **Selectivity**

Include:

- **Selective.**

- **Non-selective herbicides.**

Selective herbicide: Injures one plant and allows the other to escape injury. Selectivity of herbicides depend on susceptibility and tolerance of each plant species.

Non-selective herbicide: Injures all kinds of plants because it interferes with photosynthesis.

Factors Affecting Selectivity and Effectiveness of Herbicides

- a) Stage of growth of the plant:** young plants are more susceptible to herbicides action because of their high growth activity.
- b) Physiological/metabolic factors:** beans have a poor rate of translocation of 2,4-D. maize is able to neutralize the toxic levels of 2,4-D to less toxic 2,4-B.
- c) Herbicides characteristics:** Herbicides which interfere with photosynthesis are non- selective.
- d) Concentration:** Under high concentration herbicides kill all kinds of plants.
- e) Formulation:** Oil formulations are more toxic to plants.
- f) Method of application;** High selectivity is attained by placing the herbicide where the weed is and away from the crop.
- g) Plant morphology and Anatomy:**

Morphological and anatomical characteristics of weeds that affect selectivity:

1. **Leaf angle:** Leaf angles which are inclined e.g. grasses are less susceptible as compared to horizontal angles such as dicots.
2. **Nature of leaf surface:** Plants with thick and waxy cuticles and surfaces retain less herbicides e.g. cactus, wandering jew.
3. **Differential heights of the plants:** Shorter weeds than crops or shorter crops than weeds, selectivity are attained e.g. spraying weeds under coffee bushes.

4. **Location of growing points:** Dicots are more susceptible to herbicides because their growing points and terminal buds are more exposed than in grasses.
5. **Difference in rooting system:** Shallow rooted plants are more susceptible to herbicides than deep rooted which require herbicides with long residue effect.
6. **Specialized structures:** Plants with underground structures such as rhizomes and bulbs e.g. sedges and oxalis are not easily killed by herbicides.

Safety Precautions in Use of Chemicals

- a) Read manufacturer's instructions.
- b) Wear protective clothing e.g. overall, breathing masks, gloves, and boots.
- c) Avoid inhaling herbicide i.e. not spray against wind, not smoke and wear a breathing mask.
- d) Bath thoroughly after handling the chemical and not eat before bathing.
- e) Do not unblock blocked nozzles by blowing with the mouth.
- f) Avoid spraying against the wind/not spray on windy days.
- g) Avoid spilling herbicides on pastures and fodder crops.
- h) Dispose of empty containers and left overs e.g. by burying them.
- i) Do not wash spraying equipment in water sources used by livestock and humans.
- j) Store chemicals out of reach of children and away from food.
- k) Wash equipment thoroughly.

Advantages of using Herbicides

1. Require less labour than mechanical cultivation.
2. Adapted to control of bothersome weeds e.g. Couch grass and sedges.

3. Does not disturb crop roots and underground structures.
4. Makes control of weeds in certain crops easier e.g. wheat, burley, carrots.
5. Efficient in both wet and dry soil conditions as compared to mechanical cultivation.
6. Maintains soil structure.,
7. Convenient to use in certain crops e.g. sisal and sugarcane and weeds such as double thorn and stinging nettle which injure farmers.
8. Cheaper than manual or mechanical cultivation (on large scale farming).

Disadvantages

- Require skilled labour in mixing and application.
- Poisonous to environment and the user.
- Some herbicides have long residue effects (pollutes environment).
- Expensive—Uneconomical in small scale.

Revision questions

1. What is a weed?
2. Name two poisonous weeds.
3. State 5 harmful effects of weeds to farm crops.
4. State 5 methods of controlling weeds.
5. Give 5 factors that affect selectivity and effectiveness of herbicides.
6. State 4 problems encountered when using herbicides in the farm.
7. How does crop rotation control weeds?
8. State three beneficial effects of weeds.
9. Classify herbicides.
10. State 5 ways in which herbicides work to kill weeds.
11. State 3 factors that determine the rate of herbicide application.

12. a) What name is given to the chemicals used to control weeds?
b) Explain the correct procedure for mixing gramoxone in a sprayer for weed control.
13. Explain any 4 factors contributing to the competitive ability of weeds.
14. State 3 characteristics of annual weeds.
15. State 4 effects of water hyacinth attack.
16. State 3 limitations of mechanical weed control method.
17. Explain any 4 cultural methods of weed control in a field of maize.
18. Describe the classification of herbicides on the basis of formulation.
19. a) Name 4 biological agents used in weed control.
b) State 2 advantages of biological weed control.
20. State 3 factors which make herbicides cause crop injury or poor weed control.
21. State 4 factors to consider when choosing a method of weed control.

GRAZING SYSTEMS

There are three main grazing systems

- Rotational grazing
- Continuous grazing
- Zero grazing

1) Rotational Grazing

This refers to practice of allowing livestock to feed on a part of pasture for a period down to certain level before they are moved to the next. This gives time for pasture to properly regenerate.

Advantages of Rotational Grazing

- a) Livestock make maximum use of pasture
- b) Reduces the build up of parasites and diseases.
- c) Animal waste is distributed evenly in all fields/paddocks.

- d) Pasture area is given time to re-grow before its grazed on again.
- e) Excess pasture can be harvested for conservation
- f) Its possible to apply fertilizers in parts of the pastures are not in use
- g) It facilitates reseeding and weeding.
- h) The methods of rotational grazing include paddocking, strip grazing and tethering.

a) Paddocking

- A paddock is a fenced portion of a pasture in which animals are restricted for grazing.
- Paddocking means grazing livestock in one paddock for a short period and then moving to another.
- The size of the paddocks depends on the carrying capacity of the pasture.
- There should be a watering point at each paddock.
- A water trough is placed between two paddocks so that animals can drink water from either paddock.
- Paddocking saves herding labour. However, it is very expensive to construct.

b) Strip Grazing

- Done by allowing livestock to graze on restricted portion of the pasture at a time then moving them to the next.
- It's done on very high quality pastures. Electric fences can be used to enclose animals in a given strip of pasture. Where animals are not many herding may be done to restrict them to stay within the strips. Temporary fences may also be used instead of the electric fences.
- However, the system is quite expensive.

c) Tethering

-This involves tying the animal to a post with a rope such that it feeds within a restricted area.

-The rope may also have a metal ring that slides along a strong wire supported by strong poles.

2) Continuous Grazing (Herding)

In this type of grazing, the pasture is not allowed any resting period. This method can easily result in overgrazing if the stocking rate is not controlled. It's common in the semi-arid areas.

3) Zero Grazing (Stall Feeding)

-This is the practice of rearing animals in a permanent feeding enclosure known as the stall. Feed is cut and taken to the animals in the stalls.

-They are also provided with plenty of clean water and mineral licks.

Advantages

- i) There is quick accumulation of manure
- ii) Animals make use of the feeds without wastage
- iii) Animals produce high yields due to less wastage of energy.
- iv) It's easy to control diseases and parasites
- v) It requires little land
- vi) It allows higher stocking rate

Disadvantages

- i) High initial capital is required
- ii) High management skills are needed
- iii) Need a lot of labour
- iv) Diseases can easily spread.

REVISION QUIZ

- i.) *Use of lethal temperature.*
- ii.) *Suffocation.* This is used in the Cyprus bins where CO₂ is introduced to suffocate pests.
- iii.) *Flooding.* This can be used to control pests such as armyworms and cutworms. Moles can also be killed through flooding.
- iv.) *Proper drying of the produce.* This makes grains hard for pests to penetrate and discourages the growth of

moulds. Grains should be dried up to a moisture content of 12%

- v.) *Physical destruction of pests.* Hand picking and trapping can be used to control pests.
- vi.) *Use of scarecrows.* They scare large animals and birds out of the farm.
- vii.) *Use of physical barriers.* They include use of fences to control large animals and rat proofing in stores.
- viii.) *Use of electromagnetic radiation.* Some wavelengths of electromagnetic radiations can be used to deactivate enzymes in some insect pests. Some pests are attracted by certain wavelengths such as moths are attracted by ultra-violet rays and aphids by yellow light.

Once attracted, heat or chemicals can then be used to destroy them.

X-rays can also be used to control some storage pests.

3. Cultural Methods.

- This is the use of all the good farming practices to minimise and discourage pests from attacking the crops. Cultural practices do not eradicate or kill pests but alter the environment for pest's survival and discourage pest attack. These practices include the following.
 - i.) *Tillage.* This exposes soil borne pests to their natural enemies or exposes them to the hot sun, which kills them.
 - ii.) *Weed control.* Some weeds act as alternative hosts to crop pests. Removal of such weeds reduces pest infestation.
 - iii.) *Early planting.* This enables crops to establish earlier before pests multiply to large numbers.
 - iv.) *Burning of crop residue.* This destroys pests and their eggs reducing further attack on the next crop.

- v.) *Crop rotation.* This interferes with the life cycle of pests reducing their population
- vi.) *Use of clean planting materials.* This ensures that no pests or their eggs are introduced into the field.
- vii.) *Planting resistant crop varieties.* E.g. goose necked sorghum reduces attack by birds.
- viii.) *Closed season.* This is where a particular crop is not grown for a season to control a particular pest such as not growing maize to control maize stalk bores.
- ix.) *Crop nutrition/application of fertilizer.* This encourages vigorous and healthy growth of crops, which can tolerate and escape pest attack.
- x.) *Pruning.* This discourages conditions, which may favour the breeding grounds of pests in crops.
- xi.) *Timely harvesting.* Crops can be harvested at the right time to avoid pest attack e.g. overripe fruits encourage attack by fruit flies.
- xii.) *Proper spacing.* This discourages quick spread of pests.
- xiii.) *Growing of trap crop.* This is the growing of a crop to trap certain crop pests either before or at the same time with the main crop.
- xiv.) *Irrigation.* Overhead irrigation controls aphids in cabbages.

4. Chemical Control.

This involves the use of pesticides to control pests. Pesticides influence the pests in three ways.

- By direct poisoning.
- By inhaling.
- By ingesting.

The pesticide used should be

- Efficient
- Selective
- Cheap

- Persistent
- Safe to the user and the environment.

Classification of Pesticides

- i.) *Formulation*. E.g. soluble powders, wettable powders, fumigants, dust, liquids, granules, emulsions etc.
- ii.) *Target pest*.
 - Insecticides
 - Nematocides
 - Rodenticides.
 - Fungicides.
- iii.) *Mode of action*. They may be classified according to the way they function into the following.
 - *Stomach poisons*. These only kill those pests, which consume the sprayed crop with the chemical, hence are selective.
 - *Systemic poisons*. They are circulated to all parts of the pest once it has eaten the sprayed part of a plant.
 - *Contact poisons*. They kill the pests when they are absorbed in the body through the skin or cuticle. They are not selective and may kill many beneficial organisms such as predators, pollinators, decomposers, birds etc.
 - *Suffocants*. They kill by interfering with the breathing system after being inhaled.
 - *Anti-feedants*. They inhibit feeding on insects and other pests thus starving them to death.
 - *Repellants*. They keep the pest away from the plant.

Factors affecting the Efficiency of Pesticides

- i.) *Concentration*. Correct concentration should be used when diluting the pesticide, as it is the most effective.
- ii.) *Timing of Application*. They should be applied at the stage of development when the pest is most susceptible to the pesticide.

- iii.) *Weather conditions at the Time of application.* If the rain falls immediately after application of a pesticide, it may wash off or dilute the pesticide thereby reducing its effectiveness.
- iv.) *Persistence.* If a pesticide can remain effective for long, then the better. This ensures that more pests can be controlled.

Advantages of Chemical Control

- i.) Method is faster compared to other methods such as crop rotation, field hygiene etc.
- ii.) Most pesticides have rapid knock-down effect hence the method is more reliable and predictable.

Disadvantages

- Expensive.
- Most are not environmental friendly since they are toxic to man and livestock
- They require care and skill when handling and applying them.
- Most are non-selective and therefore they kill useful insects such as pollinators and predators.
- Pests establish resistance to pesticides if they are used continuously against them. E.g. DDT.

5. Biological Pest Control

This involves the use of a living organism, which is a natural enemy of the pest.

<i>Predator</i>	<i>Aphids</i>
<i>Ladybirds</i>	<i>Aphids</i>
<i>Wasps.</i>	<i>Coffee mealy bugs</i>
<i>Majimoto ants</i>	<i>White scales</i>
<i>Chicken</i>	<i>Cotton stainers.</i>
<i>Cats</i>	<i>Moles, rats and mice</i>

<i>Chameleons.</i>	<i>Most insects</i>
<i>Praying mantis.</i>	<i>Giant loopers</i>

The method is environmental friendly but it can be very slow.

Crop Diseases And Their Control

Disease

- It is a condition that interferes, impairs or disturbs the normal performance of an organism.
- A disease is a deviation from good health.

Harmful Effects of Crop Diseases

- i.) Lowers crop yield.
- ii.) Poor quality products hence reduced market value.
- iii.) They cause food poisoning by producing toxic substances such as *Aspergillus flavus* in maize produces *Afflatoxin*; *Ergot* in wheat and barley causes nerve endings.
- iv.) Increase the cost of production.

Classification of Plant Diseases

- Fungal diseases
- Viral diseases
- Bacterial diseases
- Nutritional diseases (deficiency)
- Other causes.

1. Fungal Diseases

They are either parasitic or saprophytic. This gives rise to the following categories.

Obligate parasitic fungi. They completely depend on other living organisms for food. They are found in plant parts such as leaves, roots, stems, fruits etc.

Facultative parasitic fungi. They can live on both the living and dead tissues.

Saprophytic fungi. They live as decomposers on dead decaying plant and animal remains. They are beneficial in nutrient recycling.

Parasitic fungi are grouped into three:

- Those with all the mycelia (vegetative part) and the fruiting bodies on the surface of the host such as *Erysiphe spp.*, which causes mildews.
- Those with the mycelia inside the plant tissues but the fruiting bodies on the surface of the host such as

Phytophthora infestans. Late blight in tomatoes and potatoes

Puccinia spp. Rusts.

Ustilago spp. Headsmut.

- Those having the mycelia and fruiting bodies all inside the host. E.g. *Fusarium spp* causing Fusarium wilts.

Examples of Fungal

1. Late Blight

- Caused by *Phytophthora infestans* .the disease affects most members of the *solanaceae* family such as Irish potatoes and tomatoes.
- The fungi are parasitic and feeds by sending short *hyphae* called *haustoria* into the cells of the host.
- Haustoria absorb plant nutrients (manufactured food) from the plant cells resulting in the death of the cell.
- The fungi reproduce by spore formation, which are dispersed by wind and raindrops.
- It spreads very quickly during warm moist conditions.

Symptoms

- Rapid drying of the leaves forming dry patches (necrotic lesions) on leaves and fruits.
- Affected fruits appear rotten and fall off prematurely.

Control

- Spraying with Bordeaux mixture and other copper based fungicides.

2. Rusts

- Cause – Puccinia spp.
- They attack the leaves and stems of most cereal crops.
 - P. Sorghi - sorghum
 - P. graminis. Maize

Symptoms

- Infected leaves have red to brown pustules hence reduced photosynthetic are and low yields.
- Crops appear rusty.

Control

Spraying with Bordeaux mixture and other copper based fungicides

3. Smuts

- Cause – Ustilago spp.
 - U. scitiminea – sugar cane
 - U. nuda - wheat
 - U. maidis - Maize.
- This produces large number of black spores, which forms black masses on maize tassels and maize cob.

Control

- Hot water treatment of the seeds.
- Use of certified seeds
- Crop rotation.
- Field hygiene e.g. rogueing and proper disposal of previous crop residue.

4. Coffee Berry Disease (CBD)

- Cause – *Colletotricum coffeanum*.
- It attacks the flowers, leaves and berries.
- Flowers and leaves have dark brown spots.

- Spots on leaves develop along the margin and later spread to the rest of the leaf causing defoliation.
- The disease attacks both green and ripe berries.
- Attacked green berries fail to form beans and are hollow.
- Attacked ripe berries have sunken wounds and are difficult to pulp/process.

Control

- Spraying with appropriate copper based fungicides.
- Open pruning.
- Resistant varieties e.g. Ruiru 11.

Other Fungal Diseases

- Damping off. *Pythium spp.*
- Powdery mildew.
- Root rots – *Armillaria spp.*
- Downey mildew – *Peronospora spp.*
- Early blight – *Alternaria spp.*
- Anthracnose – ***Colletotricum lindemuthianum***

2. Viral Diseases

- All viruses are parasitic and very small.
- They are only able to reproduce and multiply in living tissues.
- When outside living tissues, they form spores in cysts, which remain inactive until they get into a living tissue.
- They are therefore obligate parasites. Viral infections interfere with important life processes of plant such as photosynthesis, respiration, transpiration, and nitrogen utilisation.

Symptoms of Viral infections

- i.) Leaf chlorosis – loss of chlorophyll.
- ii.) Leaf curling.
- iii.) Mosaics – production of light green patches on leaves.
- iv.) Malformations (distortions) of plant parts e.g. galls (swellings), small leaves etc.

v.) Rosetting –production of abnormally short nodes hence stunting.

NB/Insect vectors such as aphids and mealy bug transmit viral diseases. Infected vegetative parts such as sugar cane cuttings also transmit viral diseases.

Examples of Viral diseases

- Maize streak. – Formation of white/yellow stripes on leaves parallel to midrib.
- Greening disease – attacks leaves of citrus.
- Tristeza – attacks citrus trees. The leaves fall off and there is dying of twigs.
- Cassava mosaic -
- Brown streak of cassava
- Potato leaf roll
- Tobacco
- Groundnut rosette.

Viral diseases are controlled by controlling the vectors.

C. Bacterial Diseases

- Bacteria are facultative parasites. They are single celled and microscopic. Not all bacteria are harmful.
- Some are beneficial to man e.g. *Rhizobium spp* which is a nitrogen fixing bacteria.
- They may be transmitted through insects, wind, raindrop splashes, manures, seeds, irrigation water, cultivation implements and pruning knives.
- They enter plants through openings such as stomata, lenticels and wounds.

Symptoms of Bacterial Diseases

- Wilting even when water is in adequate amount due to blockage of xylems.
- Cankers – results into the death of plant tissues.
- Gall formation in the infected tissues.

i) Bacterial Blight of Coffee (BBC)

Cause – *Pseudomonas syringe*.

Bacteria enter plant through wounds and natural openings. It's common in areas experiencing hailstorms.

Symptoms

- Dark necrotic lesions with water soaked margins on affected parts.
- Shoot die back.
- Cankers on mature bark and wood killing the whole plant.

Control

- Spraying chemical eg. Supanil, before, during and after the flowering periods especially during the wet weather.

ii) Bacterial wilt (*Pseudomonas solanacearum*)

- Attack potatoes, tomatoes and other *solanaceae* plants
- Affected plants wilt even when the soil is moist.
- Leaves droop and plants eventually die
- High temperature accompanied by wet conditions favour the disease.

iii) Black arm of cotton

iv) Black rot of cabbage

v) Halo blight of beans

D. Nutritional disorders

When crops do not get enough nutrients, deficiency symptoms appear eg

- Yellowing of leaves
- Drying of leaves
- Falling of leaves, flowers and fruits
- Stunted growth
- Death.

E OTHER CAUSES

I. Flooding.

- During flooding ammonia may be formed.
- Since ammonia is toxic, it has burning effect to plants.

II. Chemical

- Toxic chemical compounds in the soil may be absorbed by the plants leading to death of the plant eg. Cyanides.

III. Poor weather.

- Extreme day and night temperature may be injurious to the crop. Eg very cold temperature causes frost injury in tea.

IV. Stress

- Stressful conditions on the plant such as irregular watering may causes physiological disorders such as blossom end rot in tomatoes.

Control of crop diseases

a) Cultural methods

- This involves the use of crop husbandry practices that discourages the outbreak of diseases without the use of chemicals. They include;
 - i.) Planting resistant crop varieties that can withstand the effect of certain diseases without lowering the yields eg Ruiru II is a coffee variety resistant to CBD.
 - ii.) Practicing proper spacing of crop. Overcrowding results to quick spread of diseases.
 - iii.) Use of health planting materials. Some diseases are seed borne and can effectively be controlled by use of artificial seeds for planting.
 - iv.) Practicing field hygiene eg burning of crop residue destroying infected plants etc.
 - v.) Drying of cereals and pulses to a moisture content of 12 – 13% before storage. This discourages attack by moulds (fungi)
 - vi.) Heat treatments of some planting materials eg treating sugar cane cutting with water at 50^oc for 30 minutes control ratoon stunting disease effectively.

vii.) Proper pruning of crop destroys the micro- climate that may have encouraged build up of diseases causing organisms.

b) Chemical control

- Chemical control should be practised only when all other methods have proved to be ineffective and when it's economical.
- Chemical control measures include:

i.) Seed dressing

This is the application of fungicides before planting seeds.

The fungicides prevent attack on the planted seeds.

ii.) Spraying

This is the application of chemical such as fungicides using a sprayer.

iii.) Soil fumigation.

This is the application of chemical (fumigants) in the soil. The chemical are usually in dust or granule form and are mixed with the soil to kill soil borne diseases causing organisms in the soil eg in the control of Bacterial wilt in potatoes.

Advantage of chemicals

- Chemical act faster in controlling diseases.(effective)
- Chemical requires less labour in application.

Disadvantages of chemicals

- Expensive
- Requires skills in application
- Toxic to humans and livestock
- Pollutes environment
- Some do not break down easily

c). Legislative method

This involves imposing of regulations and laws in cases of diseases outbreaks to prevent the introduction and spreading of diseases.

REVISION QUESTIONS

1 Below is a diagram of a bird which is a crop pest.



(i) Identify the bird _____

($\frac{1}{2}$ mk)

(ii) **State two** ways by which the bird causes loss in crops.

(1mk)

(iii) **State four** methods which are used to control the pest.

(2mks)

2. Study the diagram below and answer the questions that follow.

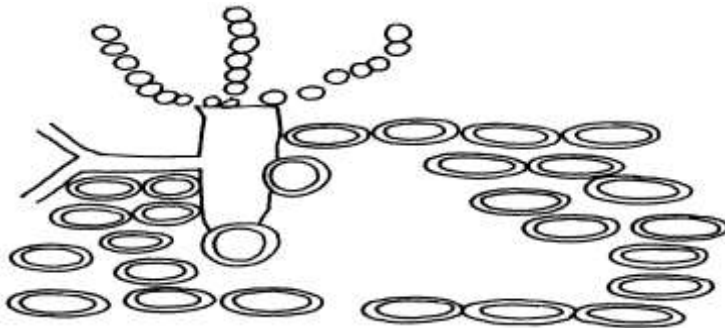

(a) Identify the fungal disease indicated above

($\frac{1}{2}$)

(b) State the causal organism of the disease identified above

(1mk)

(c) State two symptoms of the disease above
(1mk)

(d) State one control measure for the disease in the control field (1mk)

3. The diagram below shows a kale seedling attacked by a pest.

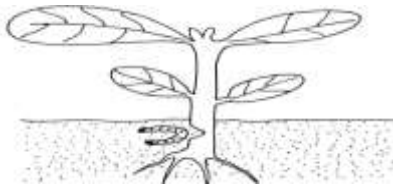

a) Identify the pest. (1mk)

b) What damage does the pest cause to the crop?
(1mk)

c) State one method of controlling the pest.
(1mk)

d) Name two other insect pests other than the one identified in (a) above that attack kale in the field. (2mks)

4. Describe the physical and cultural measures employed in the control of pests in crop production. (20 marks)

5. Given the pest shown in the diagram below



i) Name the barrier you would put on a grain store to control the pest

ii) Apart from the use of barriers list four other physical methods of pest control in and out store. (2mks)

6 (a) Identify farm storage pests shown below



(b) Name crop products attacked by each of the above pests (1 ½ mks)

(c) Name one chemical control of the above pests (½ mk)

7. Define the following terms as used in crop pests and diseases; (2mks)

a) Economic Injury Level. (EIL)

b) Integrated Pest Management (IPM)

8. Below is an illustration of a maize cob attacked by smut disease. Study: it carefully and answer the questions that follow:

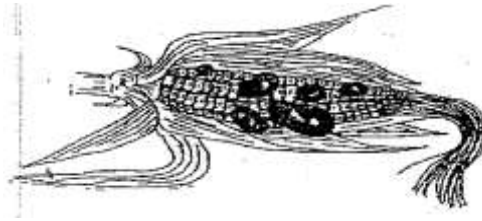

a) Beside what is visible on the maize cob. State **two** other symptoms of the disease. (2mks)

b) State **three** control measures of the above disease. (3mks)

9. Study the crop pest illustrated below.



(a) Identify the crop pest. (1mk)

(b) State **two** effects of the above pest. (1mk)

(c) State **three** methods of controlling the pests. (3mks)

10) Describe the methods of disease control in crops under the following headings.

Cultural methods (14 Marks)

Chemical methods (6

Marks)

11) The diagram below represents crop pests



.....  (1/2 mk)

(b) Name **Two** crops that are attacked by the above pests (1mk)

(c) Give **three** control measures (1 1/2 mks)

ANSWERS

1. i) Identify-A-Weaver bird (1x 1/2 = 1/2 mk

ii) 2 ways – bird causes damage

i) Eats grass

2) Causes the grains to fall off

3) Exposes maize cobs to rain leading to rotting

4) Strips the leaves (2x 1/2 1mk)

2. (a) Blight (1x 1/2 = 1/2mk)

(b) phytophthora infestans(1x1=1 mk)

(c) - fruits rot and fall prematurely

- Brown lesions on stems, leaves and fruits (2x 1/2 =1 mk

(d) Spraying using fungicides/Bordeaux mixture (1x1 mk)

3. a) - Cut – worm . (1 x 1 = 1mk)

b) Cuts the stem of seedlings (1 x 1 = 1mk)

c) - Application of appropriate pesticide / dust soil with aldrin and rake into soil.

(1 x 1 = 1mk)

d) i) Aphids

ii) Sawfly.

(2 x 1 =

2mks)

4. Physical and cultural measures employed in control of pests in crop production

Physical methods

- i) Physical destruction of pests which involve hand picking or trapping and killing them eg moles in the garden
- ii) Flooding-some pests like cut worms and army worms will be drawn if flooded. Flooding may be used to kill underground pests like moles
- iii) Proper drying of the produce-drying of grains make them hard for pests to break and penetrate hence discouraging the growth of mould. Grains should be dried to moisture content of about 11-13% moisture content
- iv) Use of electromagnetic radiation-certain wavelength of electromagnetic radiation like radioactive. Radiation may be used to deactivate enzymes in some insects and pests
- v) Use of lethal temperature-this involves the use of extreme temperatures either too cold or too hot conditions to control pests by inhibiting their survival i.e. use of hot water to control pink ball worm
- vi) Use of physical barriers-this include use of materials that prevent pests from getting to the crop i.e. rat guard/metal plates on posts of raised granaries. Construction of fences around the field and trenches to control large animals

- vii) Suffocation-has been used in Hermetic Cyprus bins where build up of carbon (iv) oxide is used to suffocate pests
- viii) Use of scarecrows-are used in scaring large animals and birds out of the farm

Cultural method

- i) Closed season-the period in which a susceptible crop is not grown in order to control a certain pest or group of pests. During this period crop residues are collected and disposed off to ensure destruction of the pest.
- ii) Timely planting-early planting of crops are more likely to escape pest attack than late planted ones eg maize stalk borers
- iii) Timely harvesting- some storage pests like grain weevils attack the crop while in the field therefore early harvesting will enable the crop escape the attack
- iv) Proper tillage- field cultivation will expose the pests which are soil borne like white grubs. The pest is exposed and scorched by the sun or eaten by birds and other predators
- v) Planting resistant crop varieties-plant breeders have developed plants which have natural protective mechanisms against pest attack i.e Goose necked sorghum against birds
- vi) Field hygiene- this means keeping the field free from any plant materials harbouring pests i.e. Rogueing and removal of crop residues from the field
- vii) Alteration of environmental conditions-creations of certain micro-climate that is not conducive to some

- insects i.e. open pruning in coffee to discourage antestia bugs, mulching reduces thrips
- viii) Trap cropping-a crop which is planted before or together with the main crop purposely for attracting away from the main crops. The pest is then killed by either spraying with chemicals, ploughing the crop or rogueing.
 - ix) Crop rotation-crops which are more preferred by a particular pest are rotated with those that are not or less preferred i.e. groundnuts and potatoes that control nematodes. This starves the pest to death.
 - x) Destruction of alternative hosts-some weeds act as alternative host to crop pests. The removal of such weeds reduces pest infestation
 - xi) Crop nutrition- application of fertilizers and manure makes the crops to grow strong and be able to resist and escape attack.
 - xii) Use of clean planting materials- this prevent introduction and spreading of crop pests. Seeds, suckers and crowns should be free from pests
 - xiii) Proper spacing- proper spacing makes it difficult for pests to move from plants to plant while close spacing in groundnuts discourage Aphids
 - xiv) Use of organic manure-FYM, compost manure has been found to discourage various pests ie eel worms
 - xv) Irrigation-overhead irrigation is able to control Aphids in cabbages

20x1=20 marks

6. (a) Identify farm storage pests shown below.

(a) Maize weevil

(b) Bean weevil / bean bruchid

© Flour weevil.

(b) Name crop products attacked by each of the above pests.

(a) Maize /wheat /barley/sorghum grains;

(b) Bean /bonavist bean /butter bean seeds;

© Maize /wheat/barley/sorghum/millet flour

(c) Name one chemical control of the above pests.

- Use of actellic powder on dry grains and seeds of maize and beans
- Respectively/primiphos-methy/organophosphate. (1/2 mark)

7 – it is the level at which the tolerance of a plant has been exceeded. (1mk)

- It is the combination of many methods to effectively control pests. (1mk)

8(a) -Severe dwarfness

-Increased tillering

(b) -Planting resistant varieties

-Use of certified seeds

-Field hygiene

-Crop rotation

9(a) -Maize weevil

(b) -Makes tunnels beneath the seed coat

-Make circular holes on the surface of the grain

(c) -Dusting maize cob with malalton

-Fumigate maize with methyl bromide

-Proper storage hygiene

-Ensure grains are stored at correct moisture content

10 **a) Cultural methods of crop disease control.**

- Using healthy planting materials to prevent the crops from being infected by seed borne diseases.
- Practicing field hygiene such as a burning crop residue using clean implements, clean weeding to destroy micro-habitat for diseases.
- Proper seedbed preparation e.g. Control of root rot disease.
- Proper spacing to control dumping off diseases especially in nursery bed.
- Heat treatment to control ratoon stunting disease in sugar cane.

- Proper drying of cereals and pulses for proper storage.
- Use of disease resistant varieties e.g. Ruiru II, Resistant to CBD

Any 7, 1 for mentioning and 1 for explaining 7 x 2 = 14 marks

b) Chemical disease control in crops

- Through seed dressing application of fungicides on seeds before planting.
- Sol fumigation – application of fumigants in soil to control soil borne diseases.
- Spraying – application of fungicides / insecticides.

Any three 1 for mentioning and 1 for explaining 3 x 2 = 6 marks

FORM FOUR AGRICULTURE NOTES

LIVESTOCK PRODUCTION V (POULTRY PRODUCTION)

Introduction

The term **poultry** refers to all kinds of domestic birds kept for meat or eggs production. They include turkeys, ducks, geese, guinea fowls, chicken, ostriches and pigeons. The management of poultry aims at production of high quality eggs and meat to meet the ever increasing market demand.

Selection and Breeding

Small scale farmers increase their flock by keeping breeds that go broody. However commercial poultry farmers buy day old chicks from recognized hatcheries such as Kenchic and Muguku. Hybrids are not recommended for breeding as their hybrid vigour would decline in their offspring and many do not go broody. Broodiness is the desire to sit on the eggs.

The birds selected should have the following characteristics.

- Young
- Healthy
- Able to go broody
- Prolific
- Good mothering ability.

Commercial farmers should also consider the following.

- Whether the enterprise is for meat or egg production

- Age, that is either day-old or at point of laying.
- Breed of birds in respect to egg colour and size of birds.
- Production, which is percentage laying or growth rate.

NB/. After the selection of the breeding stock, cocks are allowed to run with hens daily to ensure that all the eggs are fertilised

Composition of an Egg

The parts of an egg include the following.

- The shell
- The shell membrane
- Air space
- Egg white (albumen)
- Chalazae
- Yolk.

The shell

It forms about 10-12% of the total egg content and is largely made up of calcium and phosphorous compounds which make it hard. It gives the egg its shape and provides protection to the inner contents of the egg. The egg shell is porous and allows gaseous exchange to take place. This makes it possible for the embryo to develop.

Shell membrane

This forms the inner lining of the shell and makes about 1% of the egg content. It is formed of two separate membranes which closely adhere to each other. The two membranes separate at the broad end to form an air space/air cell.

The inner membrane is about 0.015mm thick and the outer one is about 0.05mm thick.

The air in the air space is used by the developing embryo during incubation.

Albumen/Egg white

The albumen forms about 55-60% of the total egg content. It is a jelly like colourless fluid when fresh and turns white when cooked. It is divided into four major parts: chalazae and chalaziferous albumen, thin inner albumen, thick albumen and outer thin albumen. The albumen surrounds the yolk and serves as a food reserve to the developing embryo. It is mainly protein.

Chalazae

This forms about 3% of the albumen and it's a dense white mass floating all over the place within an egg. It has two twisted cords which hold the yolk in place at the centre of the egg. The two chalazae hold the yolk from both ends of the egg thus allowing the yolk to move the germinal disc always to the top position. This is important during incubation for the purpose of heat transfer to the developing embryo. If the chalazae are broken the yolk is displaced from its normal position.

The Yolk

It is divided into three major parts and forms about 33% of the total egg content. It is yellow in colour and spherical. Its main function is to supply for all the embryo requirements since it contains food reserves for the developing chick. The yolk is rich in vitamins, fats, minerals and proteins. The three parts are:

- Germinal disc
- Pigments
- Vitelline membrane.

The germinal disc: this is formed from the ovary after fertilization and is always found at the top of the yolk as a

small spot regardless of what position an egg is resting. The disc is joined to the centre of the yolk by a funnel shaped structure called the streak/lutebra. This allows maximum heat transfer to the developing embryo within the yolk.

The egg pigments: The pigment contained in the yolk always comes from the food the bird eats and also from its body. This pigment is known as Xanthophylls and is responsible for the colour of the shell and that of the yolk (yellow)

The vitelline membrane: the vitelline membrane surrounds the yolk and therefore gives the yolk its shape. If the egg is not properly stored, this membrane may break up causing the yolk to come out of it.

Incubation of eggs

This refers to the embryonic development of a fertilized into a chick under correct conditions which will ensure that a chick is hatched from the egg. In chicken these conditions must be provided for 21 days while in turkeys and ducks this takes 28 days.

Selection and Care of Eggs for Incubation

Eggs for incubation should have the following characteristics.

- Should be fertilized
- Medium sized-55-60gm in weight. Lighter or heavier weight lowers hatchability.
- Have smooth shell
- Oval in shape
- Free of any cracks in the shell
- Clean to ensure that the pores are open
- Not have abnormalities such as blood spots, meat spots or double yolk
- Should be fresh – collected within one week and not more than 10 days.

NB/. The internal condition of the egg is examined through egg candling.

Egg Candling

This is the method used to check the freshness of an egg for physical abnormalities or likelihood of being hatched. It is done by passing a strong light through the egg in a dark room. The source of light may either be a torch, candle or electric bulb.

Procedure of candling

The egg is placed over a hole made on a cardboard box. A light under the box is then put on. The observer then looks at the egg against the light below. The following can be observed through egg candling.

- The size of the air space
- If the egg is fertilised (the germinal disc will be seen as a black spot).
- Whether the yolk has blood spots.
- Whether the shell has cracks
- Whether the egg shell is broken
- Whether the shell is very porous.

Incubated eggs are candled two or more times.

First candling is done between the 5th and 7th to check for fertility. If they are fertile, blood veins are seen. If they are not they appear clear.

The second candling is done on the 18th day to confirm the presence of the chick. An egg with a living embryo clearly shows a large section containing the embryo and a smaller section which is clear containing the air space.

Methods of Incubation

1. Natural incubation

This method involves the use of a broody hen to sit on the eggs. The hen provides the necessary conditions for incubation e.g. warmth, turning the eggs etc. the hen must sit on the eggs for 21 days for successful embryonic development. A hen normally shows some signs when it is about to go broody.

Signs of Broodiness in Poultry

- i) Prolonged moulting
- ii) Tendency to sit on the eggs after laying
- iii) Number of eggs laid are few
- iv) Plucking of feathers from the abdomen/breast region
- v) Produces a characteristic sound and becomes aggressive.

Preparation and Management of Natural Incubation

- i) Ensure the hen is completely broody. i.e. shows the ability to sit on the eggs for long hours. The broodiness can also be induced by use of China clays.
- ii) Prepare the nest in a secluded place of the poultry house. The nest can be a wooden box, karai, a woven basket or a carton box. The nesting box should be spacious to allow movement of the hen. The nest should be lined with some nesting materials such as dry grass, sawdust or wood shavings to maintain warmth in the nest.
- iii) Give an adequate number of eggs to the broody hen i.e. 10-15 eggs. A hen may not cover more than 15 eggs hence low hatchability.
- iv) Set the eggs in the evening or night but not in the morning so that the chicks will start emerging on the evening or night of the 21st day. When the chicks start emerging in the morning, the hen will

walk out with a few chicks and leave the un-hatched ones to die.

- v) Regularly dust the hen with appropriate pesticides so as to control external parasites such as fleas, mites etc.
- vi) Allow the bird to occasionally move out to scratch and exercise.
- vii) Feed the brooding hen daily and provide adequate clean water.

NB/. The hen should not be disturbed at all.

Advantages of Natural Incubation

- i) Less skill is required
- ii) It is not labour intensive as there is no turning of the eggs and checking of temperatures.
- iii) It's a cheap way of multiplying birds i.e. small scale farmers who cannot afford incubators can multiply their flocks using this method.
- iv) Hatchability is very high compared to artificial incubation therefore reducing the risk margin.

Disadvantages

- i) Only few chicks can be hatched at a time by one hen
- ii) Egg production is reduced when the birds go broody.
- iii) It's only possible with breeds that go broody.
- iv) The farmer cannot plan when to incubate.
- v) Diseases and parasites can easily be transmitted to the chicks from the hen if it is infected.

2. Artificial Incubation

Under this method all the conditions necessary for the hatching of the eggs are provided artificially by equipment called an incubator.

Conditions Necessary for Artificial Incubation

1. *Temperature:* Temperature should be maintained at 37.5°C – 39.4°C. Lower or higher temperature would kill the developing embryo.
2. *Fresh Air / Ventilation:* There should be adequate fresh air circulating in the incubator. The fresh air is required by the developing embryos. Ventilation facilitates gaseous exchange and helps to control humidity.
3. *Relative Humidity:* It should be about 60%. If it is too low, the embryos may lose moisture and die. Water is placed in a tray within the incubator to maintain the humidity. The damp cloth also assists in maintaining the relative humidity. High humidity lowers hatchability and leads to production of large chicks which look abnormal. It also results into dampness which predisposes the eggs to infections.
4. *Egg Turning:* This is quite important in the management of an artificial incubator. This helps to avoid the germinal disc sticking onto the egg shell leading to the death of the embryo. Wrong turning of the egg may lead to breaking of the blood vessels. Turning should always be done along the axis of the eggs and each time in a different direction. Some incubators have automatic turning devices.

Management of the Incubator

The following should be observed for artificial incubation.

- i) The incubator should be cleaned and disinfected or fumigated before putting in the eggs.
- ii) Eggs should be turned every 6-8 hours each day. However in the first 24 hours and the last three days they should not be turned. These are the critical stages of embryonic development. They should be turned around 180°C.

- iii) Any egg found to be infertile on the 5th day should be removed.
- iv) Remove any broken eggs.
- v) Maintain temperature within the set range
- vi) Add water as necessary to maintain the correct humidity.

Advantages of Artificial Incubation

- i) It's possible to plan when to have the chicks.
- ii) Many chicks are hatched at once
- iii) If management is good, there is no danger of infecting the chicks with diseases and parasites.
- iv) The incubator is usually ready when required.
- v) Egg production is not affected by incubation as the hens do not go broody.

Disadvantages

- i) Incubator is expensive to buy hence has high capital investment.
- ii) More labour intensive.
- iii) More skills required
- iv) Have high risks of damaging all the eggs if the requirements such as temperature or relative humidity are not strictly observed and controlled.
- v) Only viable in large scale hatcheries.

Sources of Chicks

For success in the poultry enterprise, the following factors should be put into consideration.

- i) Reputation of the supplier
- ii) The type of chicks required in relation to size, breed, sex etc
- iii) Time factor i.e. how long the chicks will take in transit from the hatchery to the farm. Very long hours of transportation cause stress to the chicks.

Arrangement should be made to feed the chicks on transit if the source is very far.

The most reputable sources of chicks in Kenya are;

- i) *Muguku Poultry Farm- Kikuyu.*
- ii) *Lake Chicks Hatcheries – Kisumu*
- iii) *Kenchic Hatcheries – Athi river*
- iv) *Stockplan Hatcheries – Mombasa*
- v) *Sigma Supplies – Nairobi*
- vi) *Ken Bird – Nairobi*

Brooding and Rearing of Chicks

Brooding is the rearing of chicks from one day old to the time they are taken to the main house. Brooding is a very critical and difficult period in the management of birds. There are two methods used in brooding the chicks.

- i) Natural Brooding
- ii) Artificial Brooding.

Natural Brooding

This follows natural incubation. The hen is allowed to provide warmth and other requirements to the chicks. Feed and water should be provided for both the hen and the chicks. The hen stays with the chicks until they are old enough to feed themselves.

Advantages

- i) It is cheap
- ii) It is suitable for most small poultry farmers.
- iii) It is less labour intensive

Disadvantages

- i) Only possible where the hens go broody
- ii) It is not suitable for large scale production of birds.

- iii) Lowers the egg production during the brooding period.

Artificial Brooding

This refers to keeping of the chicks in a structure called a Brooder where food and other requirements are provided. Chicks remain in the brooder for 6-8 weeks.

Requirements in an Artificial Brooder

1. *Litter*: this should be in the form of wood shavings. This should be on the floor. It maintains warmth and absorbs moisture.
2. *Fresh air*: holes for ventilation should be made on the walls of the brooder for gaseous exchange. The holes however should not allow draught into the brooder.
3. *Heat source*: there should a wire guard round the heat source to prevent the chicks from being burnt. Correct temperature should be maintained at 32-35°C in the first week, 29-33°C in the second week and 26-30°C in the third week. The heat sources include electric bulbs, charcoal burners, lantern, kerosene and gas burners. The heat source should be withdrawn gradually to avoid stress. If it were withdrawn at once, the chicks would overcrowd at one point of the brooder resulting in deaths. A thermometer should be used to check the temperature. The behaviour of the chicks can also be used to tell whether the temperature is correct. When the chicks move away from the heat source then the temperature is too high, while overcrowding around the heat source means the temperature is too low. When the temperature is optimum the chicks are found evenly spread all over the brooder floor.

The brooder should have sufficient lighting to allow the chicks to see water and food. Very bright light makes the

chicks toes to shine hen toe pecking and also makes the chicks blind. Dim light is therefore recommended.

4. *Shape of the brooder.* There should be no sharp corners in the brooder. Such corners would encourage overcrowding hence suffocation of the chicks.

5. *Equipment*

a) *Feeder:* There should be sufficient feeders for the chicks. If the chicks overcrowd during feeding then more feeders should be made available. The feeders should be kept clean. During feeding the chicks should be given a feeding allowance of 1 inch per chick during week 1-2 and 2 inches per chick from weeks 3-6. The feeders should have a rotating bar to avoid the chicks contaminating the feed by stepping or defecating on the feed.

b) *Waterers:* The waterers should also be made in such a way that the chicks do not defaecate or step into the water. They should be pointed at the top so that the chicks cannot perch. They should always be kept clean. During the first to second week the appropriate spacing for the waterers should be 0.2 inches per chick and 0.4 inches per chick from week 3 to week 8.

Brooder and Brooder Management

a) *Preparation before the chicks arrives.*

- i) The brooder should be made ready 2-3 days before arrival of the chicks. The brooder house should be washed and disinfected. Spread litter then cover it with newspapers. Newspapers help to prevent the chicks from eating the litter.
- ii) Place water and feed equipment in the brooder house. Ensure they are clean. Place food in the feeders and water in the waterers.

- iii) Provide heat source in the brooder. Check to ensure the heat source is functional. Turn on the heat source on the day of chicks' arrival.

b) Day of arrival of chicks.

Vaccinate them if they were not vaccinated in the hatchery. Remove any dead chicks and dispose off properly.

c) Feeding

- i) Remove the newspapers after the chicks have learnt to eat from the feed troughs.
- ii) Provide chick mash till the eighth week. Chick mash has 20-22% DCP and vitamins A and D. it is highly digestible. Ensure the chicks are given adequate amounts of feeds at all times.
- iii) In the sixth week introduce grit or sand to help in digestion. Also introduce roosts for the chicks to perch.
- iv) In the seventh week, introduce growers mash. Start with growers mash mixed with chick mash at a ratio of 3:1 respectively. Gradually reduce the amount of chick mash as the amount of growers mash is increased. When the chicks are 8 weeks old, they are removed from the brooder.
- v) At the ninth week, chicks are fed on growers mash only and are now taken to the main poultry house.
- vi) Clean the troughs and waterers daily.
- vii) Provide adequate clean water daily.

NB/. On average a chick uses 1.5-2.2 kg of chick mash during the brooding period of 8 weeks.

d) Parasite and disease control

- i) Vaccinate chicks against Gumboro after 2 weeks, Newcastle, 3-4 weeks and fowl typhoid at 7 weeks of age.

- ii) Dust chicks with appropriate pesticides such as pyrethrins to control external parasites e.g. mites, lice etc.
- iii) Provide antibiotics mixed in chick mash or drinking water to protect against disease attacks e.g. coccidiostats are incorporated in drinking water to control coccidiosis.
- iv) Isolate and treat sick chicks
- v) Dispose off dead chicks properly
- vi) Disinfect the feeders and waterers. Provide a footbath at the entrance of the poultry house.

e) Other management practices.

- i) Debeaking should be done 8-10 days towards the end of the brooding period.
- ii) Keep proper records of the feeding programme, treatment and the number of deaths of the chicks.

Management of Growers (9th week-20th week i.e. point of lay)

From the 9th week the birds are referred to as *growers* or *pullets*.

a) Feeding

- 1) Feed the growers on 115 grams of growers mash per bird per day. Growers mash contains 16-17% crude protein, vitamins and mineral salts.
- 2) Supplement the growers mash with grains and greens. Hang the greens to provide exercise for the birds.
- 3) Introduce layers mash from the 16th week and increase gradually.
- 4) At the 12th week onwards soluble grit should be provided. This provides enough calcium which is necessary for hard egg shell formation.

5) Provide clean water *ad libitum*.

b) *Parasite and disease control.*

- i) At the 18th week vaccinate against fowl pox. Give a booster vaccine against Newcastle disease at 20 weeks of age.
- ii) Drench the birds regularly against internal parasites.
- iii) Dust the birds with appropriate pesticides against pests such as fleas, mites and lice.
- iv) Control predators
- v) Clean and disinfect waterers and feeders daily.

c) *Other management practices.*

- i) Provide more floor space for the birds as compared to when they were in the brooder.
- ii) Keep litter as dry as possible by turning it regularly or scattering grains on it to facilitate turning of the litter by the birds.

NB. Birds start laying at 18-21 weeks of age depending on the breed. Light breeds begin to lay at 18-20 weeks, some hybrids start laying at 18 weeks while indigenous breeds begin to lay at 23-27 weeks.

Feeding and Rearing of Layers

- Provide enough floor space, roosts, feeders, and waterers
- Give each hen about 120 grams of layers mash per day. The layers mash contains 14-16% DCP, Vitamins A, B, C and minerals.
- Provide clean water always
- Vaccinate every 6 months against Newcastle and fowl typhoid
- Keep the litter as dry as possible.
- Provide enough laying nests in the poultry house.
- Collect eggs twice, noon and evening

- Hang green leaves to keep the birds busy preventing cannibalism
- Incorporate grains at the rate of 65 grams per bird per day.
- Cull non layers and cannibals
- Provide soluble grit or oyster shells all times to ensure strong shelled eggs and efficient digestion.

Feeding and Rearing of Broilers

Broilers are referred to as table birds. They are kept for meat production. They exhibit high growth rate and have a very high feed conversion ration. They usually achieve a weight of 2kg in about 60 days. The following practices are carried out.

a) Feeding

- i) Chicks kept for broiler production are fed on broiler starter mash. The feed contains 20-24%DCP, vitamins and minerals essential for rapid growth.
- ii) Provide adequate clean water always
- iii) From week 4-5 gradually introduce broiler follow on mash or pellets. It contains 18-20%DCP. It encourages development of lean meat i.e. discourages over fattening. The feed should be provided ad libitum.
- iv) From 8th week up to slaughter the birds are given broiler finisher pellets.

b) Parasite and disease control

- i) De-worm regularly
- ii) Dust the birds to control external parasites
- iii) Vaccinate against common disease e.g. Newcastle disease at 3rd-4th weeks
- iv) Incorporate coccidiostats in the broilers pellets.
- v) Dispose off dead birds properly.

c) Housing

Broilers are best managed under the deep litter system. Its floor space requirements are low, about one square foot per bird. The house should be well ventilated for efficient air circulation. Broilers should be kept in dimly lit houses to reduce their activity, ensuring that most of the feed taken in is used for growth.

Rearing Systems

The method of keeping poultry is referred to as rearing system. The choice of the system to use depends on the following factors.

- Land availability
- Labour availability
- Capital
- Security
- Market
- Availability of appropriate equipment
- Topography of the land to facilitate easy drainage
- Knowledge of the farmer.

There are four main rearing systems i.e.

- Free range
- Fold system
- Deep litter
- Battery cage system

1) Free Range/Extensive system

Birds are allowed to move freely in a fenced ground that has a house to provide shelter at night and during the rainy seasons. The laying nests are also put in the house. Feed and water troughs are placed outside but should be protected against rain.

Requirements

1. *Land*. Should be adequate, well drained and with trees for shade. It should be fenced. About 100 birds should be kept in 1 acre.
2. *Runs*. The land should be partitioned to allow rotation. This reduces diseases and parasite build up. The partitioned areas are called runs.
3. *House*. The house should be movable or at the centre of the runs.

Advantages

- i) Cannibalism and egg eating are reduced as the birds are not overcrowded.
- ii) Birds exercise hence good growth
- iii) No need to provide grit as the birds can pick it from the ground
- iv) Less feed is used as the birds supplement with insects and grass.
- v) Manure is evenly spread in the runs hence vegetation regeneration
- vi) It requires low capital investment
- vii) Low labour requirement.

Disadvantages

- i) A lot of land is needed for the birds
- ii) Birds can be eaten by predators or stolen
- iii) Eggs get lost in the runs
- iv) Dirty eggs
- v) Difficulty in close supervision of individual birds
- vi) Breeding programme not easily followed
- vii) If the perimeter fence is not adequate the birds can damage crops on the farm.
- viii) The range area may become contaminated with diseases and parasites

2) *Fold System / Semi Intensive System*.

This is a system where birds freely eat vegetation but are confined in small houses called folds or arks.

- A fold system measures 3.5m long, 1.5m wide and 1.5m high. Such a fold can accommodate 10-15 birds.
- 1/3 of the fold is roofed to provide shelter and the rest is open but enclosed by chicken wire mesh. The unroofed part allows sunlight and is used for exercise and feeding on the grass.
- The folds should be moved to a new ground daily. This reduces pest and disease build up, provides fresh grass to the birds and avoids accumulation of droppings.

Advantages

- i) Manure is uniformly spread in the field
- ii) Less feeding costs since the birds supplement the feed with insects and grass
- iii) There is no need of fencing
- iv) Reduced pest and disease build up.

Disadvantages

- i) Folds don't last long due to too much handling
- ii) Few birds are kept per fold
- iii) Very laborious
- iv) Egg production records per bird are difficult to keep
- v) The returns per unit land are relatively low.

3) Deep Litter System.

This is an intensive system. In this system, birds are confined within a big house.

Requirements of a deep litter system

i) Site

The land should be well drained.

ii) House

- Should be leak proof
- The leeward side should be open from 60-90cm above the ground. This area should be covered with a wire mesh. The floor should have litter.
- The litter keeps the floor warm and absorbs moisture. Litter materials include crushed maize combs, coffee husks, sawdust, wood shavings etc.
- The litter should be 15-30cm deep.
- Litter should be turned regularly to mix the droppings. Grains should be thrown regularly on the litter for the birds to scratch for the grains thus turning the litter.
- The floor space requirement should be 1m² per 2- 3 birds.

iii) Feeders and Waterers

They should be enough and should always be cleaned daily to avoid any infections.

iv) Roosts and Perches

Roosts are timber frames on which the birds perch for rest. They should be about 30cm per bird and should be about 1-1.2m. They should be movable for easy removal of droppings and for easy cleaning. *Diagrams*

v) Laying Nests

Provide laying nests in the poultry house.

Requirements for laying nests

- Should be dimly lit to discourage egg eating
- Large enough to accommodate the bird comfortably. Nests are of two types, individual type and communal type. Individual type should measure 25-30cm wide, 30-35cm high and 30-36cm long. Communal nests

can accommodate 50-60 birds and they measure 1.35m – 1.5m long, 30cm wide and 35cm high on the front side and 75cm on the back side. It should have a door measuring 20x20 cm wide.

- Place dry clean beddings

Advantages of the deep litter system

- i) High stocking rate
- ii) System can be used for rearing a breeding stock
- iii) Fast accumulation of manure
- iv) Birds are safe from predators and thieves
- v) Less loss of eggs
- vi) Low labour requirements once everything is in place.

Disadvantages

- i) There is a likelihood of pest and disease accumulation in the litter
- ii) Cannibalism, egg eating, feather plucking and toe pecking are common.
- iii) Individual egg production record is not possible
- iv) Litter may be difficult to find in some areas
- v) Feeders and waterers may be contaminated by litter if not properly placed
- vi) Eggs may become dirty if they are laid on the floor or if the laying nests are not clean.

MILK AND MILKING

Milk

White substance secreted in the mammary glands of female animals. It is secreted as food for their young ones.

It is also processed into products such as butter, cheese and ghee.

Composition of milk

The composition of milk varies from one animal to another as shown below. It contains proteins, carbohydrates (lactose) fats, minerals and water.

Animal	Protein %	Fat %	Lactose %	Ash%	Water %	Total solids %
Human	1.3	3.8	7.0	Trace	87.3	12.6
Sheep	5.4	6.2	4.3	0.95	78.9	21.1
Goat	3.3	4.1	4.7	0.79	87.9	12.0
Cow	3.3	3.7	7.3	0.72	86.0	13.0

Factors affecting the milk composition

- i) **Age of the animal;** young animals produce milk with high butter fat content than old animals.
- ii) **Physiological Condition of the animal;** under conditions such as extreme emaciation, the butter fat content significantly drops. Pregnant animals also produce milk low in butter fat content.
- iii) **Completeness of milking;** the last milk to be drawn has the highest butter fat content. Also the milk drawn from animal in the evening has higher butterfat content as compared to that obtained in the morning.
- iv) **Stage of lactation and pregnancy;** butterfat content, proteins and minerals in milk are usually higher at the middle of the lactation period and drop towards late gestation.
- v) **Type of food eaten by the animal;** animals eating a lot of roughages produce milk rich in fats, proteins and lactose than animals which is fed on a lot of grains. This is because roughages produce a lot of acetic acid (*a volatile fatty acid which is*

used as a source of energy in the mammary glands to synthesize milk).

- vi) **Breed differences**; different breeds produce milk with different percentage composition as shown below.

Animal breed	Protein %	Lactose %	Fat %	Cal/kg	Solids Not Fat (SNF) %	Ash/minerals %
Jersey	4.0	4.8	5.2	880	9.3	0.75
Ayrshire	3.4	4.8	3.9	748	8.6	0.75
Friesian	3.2	4.7	3.8	704	8.5	0.70
Guernsey	3.7	4.8	4.8	745	9.0	-
East African Zebu	3.3	4.7	5.5	-	8.8	0.76

- vii) *Season of the year*; fats increase during the cold season. The **solids not fats** decrease during the hot season.
- viii) *Other factors* animals under treatment produce milk of variable composition depending on the drugs used. Animals suffering from mastitis have reduced lactose because the mastitis bacteria attack the milk sugars.

Milk Secretion and Let-down

The structure of the mammary gland

It is the organ responsible for milk production in mammalian animals.

It is composed of balloon shaped secretory cells called alveoli (alveolus).

The alveoli are surrounded by a dense network of blood capillaries. These alveoli are joined together by a capsule to form a lobule with a duct. The alveoli drain their content into the lobule. Several lobules are grouped together to form a lobe which is drained by the lactiferous duct.

Many lobes form one quarter of the udder. Several lactiferous ducts drain into the gland cistern of the quarter. The quarters of the udder are anatomically separated and drain into separate teat cisterns. Each teat has an opening called a teat orifice/canal whose opening and closing is controlled by the a sphincter muscle.

Milk secretion

Milk is made from products of digestion such as blood sugar, amino acids and fatty acids. These nutrients are carried by blood into the alveoli where they are manufactured into lactose, casein and butter. Other milk components such as vitamins and minerals are also added to milk through filtration by the alveoli cells.

Milk synthesis or lactogenesis is controlled by the hormone prolactin. Low levels of oestrogen during late gestation period stimulate the secretion of the hormone prolactin by the pituitary gland. Prolactin activates milk secretion process in the mammary glands.

Milk secreted is stored in the hollow cavities of the alveoli and within the lactiferous ducts. Some milk however drains into the gland cistern where it is stored until milking.

Milk let down

This is the flow of milk from the upper region of the udder (alveolar region) to the lower part of the udder (gland cistern and teat cistern). This process of milk let down is caused by the hormone oxytocin released by the pituitary gland. Oxytocin causes contraction of the muscle fibres surrounding the alveoli. This contraction forces milk into the gland and teat cisterns. However some external factors also influence the milk let down process. These are:

- i) Taking the cow into the milking shed
- ii) Sight or smell of food in the feed trough
- iii) Rattling sound of the buckets
- iv) Sight of the milkman
- v) Massaging or washing the udder with warm water
- vi) Sight of the calf for cows used to suckling calves
- vii) Suckling by the calf

NB. Milk let down lasts for about seven to eight minutes hence the person milking must be very fast in order to remove as much milk as possible. Proper stimulation of the udder when milking is therefore very necessary throughout the milking process.

The secretion of adrenaline from the adrenal glands suppresses the effects of oxytocin. Adrenaline inhibits the supply of blood to the alveolar region causing relaxation of the muscles fibres thus there is no milk let down.

Other factors that may contribute to inhibition of milk let down include;

- i) Excitement or frightening of the cow.
- ii) Hunger
- iii) Change of milkman
- iv) Change of the milking schedule

- v) Effects of the oestrus
- vi) Feeling of pain
- vii) Strange surroundings

Before milking the alveolar cells are turgid but after milking they appear long and thin.

Clean milk production

Characteristics of clean and high quality milk

- i. Free from disease causing organisms
- ii. Has no hair, dirt or dust
- iii. Has high keeping quality
- iv. Has a good flavour
- v. Its chemical composition is within the expected standards

Essentials of clean milk production

- *Avoid flavours in milk-* bad flavours in milk are caused by feedstuffs and oxidation. Silage and feedstuffs such as Mexican marigold, onions and other fruit wastes can cause bad flavours in milk. Such feedstuffs should be given to the animals after and not before or during milking. Oxidation of milk fats occurs when milk has been exposed to the sun for a long time or if put in containers with traces of copper or iron giving it a bad flavour. Milk should therefore be protected from sunlight and should be stored in containers which are free from traces of copper or iron.
- *Healthy milking herd.* Cows should be tested regularly for milk borne diseases such as tuberculosis and brucellosis. A strip cup should always be used to check for mastitis.
- *Clean milking cows.* The flanks, underline and the whole udder should be washed and dried thoroughly before each milking. Two towels should be used. One for cleaning the udder and the other one for drying.

Any long hair on the udder and flanks should be clipped.

- *Healthy and clean milkman.* Any milkman suffering from contagious diseases should not handle milk or do the milking. The milkman should keep his finger nails short and should have his hair covered. He should preferably wear an overall when milking.
- *Clean milking shed.* The milking parlour should be kept clean. It should have a good drainage and easy to clean. It should be cleaned after every milking.
- *Clean milking utensils.* The milking utensils and equipment should be seamless and smooth to facilitate thorough cleaning. They should be washed with hot water and detergent. Keeping them in the sun during the day sterilises them.
- *Milk filtration cooling and storage.* Milk should be filtered and cooled to 5°C after milking. Cooling slows down bacteria multiplication hence improved keeping quality. The milk should then be stored in a cool, dry and dust free room or delivered immediately to the market.

Milking materials and equipment

- *Udder clothes/towels.* Two towels should be provided for each cow, one for washing and the other for drying. If the animals are many the towels are dipped in hot water or disinfected before they are used on another animal.
- *Filtering pads.* They are used for straining milk.
- *Milking jelly.* It is smeared on the teats after milking to prevent cracking. It should not be applied before or during milking.
- *Warm water.* For washing the udder before milking. It also stimulates the milk let down process.

- *Milking pails/bucket.* Should be made of materials that are free of copper and iron traces.
Strip cup. For detecting mastitis.
- *Milk cans/churns.* Used to hold milk during storage and transportation. Should also be made of materials that are free of copper or iron on their surfaces.
- *Other equipment.* Cooling apparatus, milking stool and weighing scale.

The milking procedure

Milking can be done either by hand or machine depending on the scale of farming. The following are the stages in milking.

- *Pre-milking procedure.* Milking materials and equipment are made available and within reach of the milkman. The cow is restrained in the milking parlour and given food. The udder is washed, dried and mastitis is checked.
- *Milking technique.* The proper method or technique should be used to extract as much milk as possible.
- *Procedure of proper milking.* In hand milking the teat is grasped tightly at its base between the thumb and the forefinger and the other three fingers are closed in tightly applying the pressure from the top to the bottom forcing the milk to drain out.

When the force is applied rhythmically, on the teat muscles, the orifice opens and milk is released. The base of the teat is held firmly to prevent the backflow of milk into the gland cistern.

Teats should not be stripped or pulled with fingers.

The following rules should be observed.

1. *Milk quickly and evenly.* The effect of oxytocin lasts for 5-8 minutes hence milking should be quick and efficient.
 2. *Milk at regular times.* Cows are usually milked twice a day at approximately 12 hours interval. Milking should be done the same time in the morning and evenings. High yielding cows may be milked thrice per day.
 3. *Avoid use of wet hands.* The milkman should dry his hands after cleaning the udder.
 4. *Complete milking.* All the milk should be removed during milking. Incomplete removal of milk leading to the cow drying off too soon and total milk yield per lactation is reduced.
- Post milking practices
These include weighing, recording, straining, cooling and storing it, cleaning the utensils and washing the milking parlour.

Dry Cow Therapy

This is the administration of antibiotics to an in-calf cow in its late gestation period to control mastitis during the drying off period. The antibiotic (penicillin) is infused into the udder through the teat canal using a syringe.

MILK PRODUCTS

They include the following;

1. ***Homogenized and pasteurized milk.*** Homogenization is the process by which the fat globules in milk are broken down into smaller particles and are distributed evenly in the milk. Pasteurization involves heating the milk and the cooling it suddenly. This destroys most of the harmful bacteria in the milk. Homogenized and pasteurized milk is prepared and packed by KCC, Brookside, Tuzo, Delamere

Dairies and Egerton Dairies etc. this milk is marketed as whole milk.

- 2. Ultra Heat Treated (UHT) Milk.** This is milk which has been treated at a temperature between 130 and 135°C for one second and then immediately packed and cooled. This milk has a long shelf life without refrigeration. It is marketed as whole milk.
- 3. Cream.** This is the layer of fat on the surface of the milk. It is separated from the raw milk either mechanically by use of machine separator or by hands. The machine separator spins the milk rapidly so that the centrifugal force that is created separates the fat globules from the rest of the milk.
- 4. Skim milk.** This is milk without cream. It is used in the manufacture of fat free milk powder.
- 5. Butter.** Butter is milk fat lacking non-fat solids and is obtained by churning cream in a churn. Butter contains 80% fat, 16-20% water and 1-1.5% non fat solids.
- 6. Ghee.** It's prepared by either heating cream or butter in order to remove moisture and non fat solids. Ghee contains 100% fat and is mainly used for cooking.
- 7. Curd.** It is prepared by leaving whole or skim milk unprotected to coagulate as a result of bacteria in the environment.
- 8. Cheese.** Cheese is consolidated curd. It obtained by compressing milk curd until the moisture is drained out. Cheese has an elastic texture. Acids, enzymes and salts are added to it.
- 9. Powdered milk.** This is milk prepared by drying the whole milk or skimmed milk and converting it into powder.
- 10. Yoghurt.** This is thickened flavoured milk. It is slightly acidic. The thickening is done by adding certain

bacteria and food flavours to the milk. Other milk products include ice-cream and condensed milk.

Marketing of Milk

Milk in Kenya is mainly carried out through cooperative societies e.g. KCC, Tuzo, Brookside etc.

The sale of milk in Kenya is regulated by the Kenya Dairy Board. Pricing is based on the quantity processed.

Farmers also sell their fresh milk directly to consumers and other middlemen.

Problems facing Dairy Farmers in Marketing Milk

1. Milk is highly perishable and so needs cold storage facilities which most farmers cannot afford.
2. Transportation problems. Certain milk producing areas are in accessible due to poor road network. This may delay milk delivery hence milk spoilage.
3. Special containers are required for handling of milk some of which are expensive.
4. Lack of market information on milk price and other existing marketing opportunities.
5. Price fluctuations
6. Delayed payments to farmers

Marketing of Beef Cattle

In Kenya there are three channels through which Kenyan beef farmers can market their products.

a) Kenya Meat Commission (KMC)

This is a statutory body mandated by the parliament to buy animals from the farmers, process and sell the meat products. The slaughter houses for KMC are located in Athi River, Ngong and Mombasa.

b) Livestock Marketing Division. (LMD)

This is a division in the Ministry of Livestock Development that is involved with the marketing of livestock especially those from arid and semi arid areas. The livestock division has built holding yards for the farmers to bring their animals for auction.

c) Local Slaughter Houses

These are specially constructed houses with all the slaughter facilities. Butchers buy animals either directly from farmers or from Livestock Marketing Division and take them to the slaughter houses for slaughter after which they sell meat to consumers through their butcheries. Price of meat is majorly dependent on market situations.

PRODUCTION ECONOMICS

The country's income can be expressed through the following ways.

- Gross Domestic Product
- Gross National Income
- Per Capita Income

Gross Domestic Product (GNP)

- This is the sum total of all the goods and the services produced by the residents of a country within a period of one year.
- The residents are either citizens or foreigners who have invested in that country.
- The foreigners however remit their income to their home countries hence there is income *outflow*.

Gross National Income. (GNI)

- This is the sum total of all goods and services (*in monetary terms*) produced by the nationals of a given country within a year regardless of their country of operation.
- The nationals of a given country may invest or seek employment in foreign countries. These nationals remit their interests, profits and income to their home countries.
- There is therefore income *inflow* to their country.
- The difference between income inflow and income outflow added to the GDP gives the GNI

(Income inflow – income outflow) + GDP = GNI

Per Capita Income

- This is the average per head in a country. It is obtained by dividing the gross national income of a country by the country's total population.

Per Capita Income = $\frac{\text{GNI}}{\text{Total population}}$

Per capita income is not a good measure of the economic well being of the people in a country due to the uneven distribution of the income.

Contribution of Agriculture to National Development

- Food supply
- Source of income and capital
- Source of raw materials to industries
- Market for industrial goods
- Creation of employment
- Source of revenue to government
- Foreign exchange earner.

Factors of Production

1. Land

Solid part of the earth where capital can be placed. Land is scarce and is valued depending on the following

- *The ability to produce crops and livestock.* This is based on land productivity and not size. Land productivity is determined by the soil fertility and climatic conditions of an area. Land productivity can be improved by fertilizer application, irrigation, proper tillage, soil and water conservation etc.
- *The space for construction of the farm buildings, agro-industries, urban centres and infrastructure.* All these structures are important in agricultural production. *Farmers can acquire land through the following methods.*

- Inheritance
- Buying
- Leasing from landlords
- Allocation by the government through settlement schemes.

2. Labour.

- This refers to the human physical and mental services employed in the production process.
- Labour is considered on the basis of the output of an individual and not on the number of people employed.
- The work output of labour is expressed in terms of the amount of the work done within a specified period e.g. man hours or man days.

Types of labour

Family labour

It consists of the farmer and members of his family. The tasks are assigned according to the age and ability of the family members.

Hired labour.

Its labour employed outside the family. It can be permanent or casual.

Casual labour is normally engaged at labour peaks e.g. during harvesting, planting weeding etc.

Permanent labour is normally hired on monthly basis.

How to Improve labour Productivity

- *Training.* Done formally through schools and colleges or informally through field days, agricultural shows, demonstration farms, workshops etc.
- *Farm mechanization.* Mechanization makes farm operations to be faster and efficient.
- *Giving incentives and improving the terms and conditions of service.* They include provision of housing, medical facilities, rewarding good workers and better remuneration. All these motivate labour to work hard and efficiently.
- *Labour supervision.* This improves efficiency and productivity of labour.
- *Assigning tasks based on abilities and promoting specialization.* This helps workers to know clearly their duties and responsibilities making them more efficient and accountable.

3. Capital

These are the assets that are essential in the production process. In agricultural production, capital includes tools and equipment, farm inputs, farm machines and money.

Without capital all other factors of production will be of no importance.

Types of Capital

- *Liquid capital.* This is money and can be easily converted into other forms of capital
- *Working capital.* These are raw materials used for production. They are normally consumed completely in the production process e.g. Fertilizers, pesticides, fuel, feedstuffs etc.
- *Fixed or durable capital.* These are assets employed in the production process but are not used up completely in the process. Fixed assets only depreciate in value due to wear and tear and age. They include farm buildings, farm machinery, permanent crops etc.

Sources of Capital

- *Credit facilities.* Credit may be obtained from commercial banks, cooperatives, statutory boards eg. AFC, private organisations etc.
- *Self savings*
- *Free grants*
- *Inheritance*

NB/ the higher the quality of the capital, the more the production. E.g. 10kg of hybrid seeds produce more yield than 10kg of ordinary seeds.

4. Management.

It's the process of planning and decision making in the organization of the other factors of production to minimize costs and maximize profit/output.

Functions of a manager

- Short term planning
- Long term planning
- Information gathering
- Keeping farm records
- Implementing farm management decisions
- Finding ways of overcoming constraints

- Determining the production efficiency of his enterprise.

Managerial Guideline Questions

- *What to produce.* This is determined by factors such as market demands, cultural values of the people, ecological factors and government policy.
- *How much to produce.* Determined by factors such as land, capital, labour force etc.
- *How to produce.* Determined by available techniques of production acquired through training and experience.
- *When to produce.* Determined by the season when the crops or livestock perform well or when the market is available.
- *For whom to produce.* Determined by the demand and the price of the product.

Qualities of a Good Farm Manager

1. Flexible in his decisions to adjust to the dynamic economic trends.
2. Hardworking and time conscious
3. Knowledgeable about agricultural principles such as practical farming skills, marketing and accounting.
4. Responsible, dynamic, competent, ambitious and focused.

Ways of Promoting Farm Management Skills

- Training managers
- Carrying out research on farm management
- Teaching agriculture in schools and forming 4k and YFC

The production Function

This is the physical relationship between inputs and products. It shows the quantity of output that may be expected from a give combination of inputs.

Types of Inputs

- Variable inputs
- Fixed inputs.

Variable Inputs

They vary with the level of production. They include labour force, fertilizers, seeds, feeds, fuel, pesticides, livestock, drugs etc.

Characteristics of variable inputs

1. They change in quantity required with the level of production.
2. Are added to fixed inputs for production
3. Their cost value depends on the kind and quantity used.
4. Are usually allocated to specific enterprises
5. Their cost Value is used to calculate the gross margins of various farm inputs.

Fixed Inputs

These do not vary with the level of production. They include farm machinery, permanent labour etc.

Characteristics of Fixed Inputs

1. They have fixed cost i.e. are constant
2. They do not vary with the level of production.
3. Their costs are not normally allocated to specific enterprises or product.

Input Output Relationships

Example 1

A farmer has a land fixed at one hectare

Suppose the maize seed is varied from 0kg to 25kg

The maize yield will therefore vary with the respective seed rates as shown below

Land (ha)	Input (kg of seed)	Output (90kg Bags)
-----------	--------------------	--------------------

1	0	0
1	5	10
1	10	20
1	15	35
1	20	45
1	25	60

Example 2

Suppose land and maize seed rate inputs are fixed at 1 ha and 25 kg respectively.

The nitrogen fertilizer is applied at different rates. The following relationship is realized.

Hectare	Seed rate (kg)	CAN fertiliser (kg)	Marginal input (kg)	Total Product (90 kg bags)	Marginal product (90 kg bags)
1		0	0	6	6
1	25	20	20	12	6
1	25	40	20	19	7
1	25	60	20	29	10
1	25	80	20	36	7
1	25	100	20	42	6
1	25	120	20	48	6
1	25	140	20	53	5
1	25	160	20	57	4
1	25	180	20	59	2
1	25	200	20	60	1

Plot the a line graph of CAN input against Maize output

- Land and seed rate are fixed at 1 hectare and 25 kg respectively.
- CAN fertiliser is varied at 20 kg units
- Maize yield increases as shown by the total product curve
- Marginal product is the additional return realised above the previous total product as a result of the marginal input. *E.g. when 100kg of CAN fertiliser are used, the marginal product is 6 bags.*
i.e. $42-36 = 6$
- Marginal inputs are additional inputs above the previous input.

Types of production functions

- Increasing returns production function
- Constant returns production function
- Decreasing returns production function

1. **Increasing Returns Production Function**

In this type of a function, each additional unit of input results in a larger increase in output than the preceding unit of input. This is a rare production in agriculture.

It is usually experienced in the initial low levels of inputs application as in fertilizers, seedrate, and animal concentrates etc.

Example

Egg production from individual birds with varying amounts of layers mash.

Layers	Layers mash (kg/week)	Total egg production per week	Marginal product per week
100	0	140	0
100	10	155	15
100	20	180	25

100	30	240	60
100	40	340	100
100	50	470	130

Draw a graph of amount of layers mash (input) against total egg production (output)

2. Constant Returns Production Function

In this case, the output increases at the same rate for each additional unit of input. The returns are constant to the input factor.

This function is very rare in agriculture due to presence of other factors that influence agriculture such as climate, human factors, pests and diseases.

It is only common in industries.

E.g. Production of loaves

Labour (man days)	Wheat flour (kg)	Total number of loaves	Marginal product
5	10	25	0
5	20	50	25
5	30	75	25
5	40	100	25
5	50	125	25
5	60	150	25

Draw a graph of input against output.

- *The PF curve is a straight line*
- *The slope of the curve remains the same*
- *The marginal product is constant at 25*

3. Decreasing Returns Production Function

Each additional unit of input results into a smaller increase in output than the preceding unit of input.

It is the commonest type of production function in agriculture. It is common in areas like feeding livestock in order to increase their output, fertilizer application in crop production, feeding layers for egg production etc.

Example

Maize production in 90kg bags from varying amounts of NPK fertilizer application

Land (1ha)	NPK fertilizer input (kg)	Total maize production (in 90 kg bags)	Marginal production (in 90kg bags)
1	0	5	5
1	30	12	7
1	60	28	16
1	90	47	19
1	120	59	12
1	150	65	6
1	180	68	3
1	210	70	2
1	240	70	0
1	270	68	-2

Draw a graph of input against output

NB/

- Initially each additional unit of inputs leads to a larger increase in output than the preceding one. (i.e.0-90 kg of NPK)
- Thereafter, the increase is at a decreasing rate i.e. between 90-210kg of NPK input. At this point the law of diminishing returns starts to operate.

- Any further application of the NPK fertilizer results in a decline in output.

Economic Laws and Principles

They include:

- The law of diminishing returns
- The principle of substitution
- The principal of equi-marginal returns
- The principle of profit maximization

1. The Law of Diminishing Returns

It states that *if successive units of one input are added to fixed quantities of other inputs, a point is eventually reached when the additional (marginal) and average product (output) per additional unit of input will decline.*

Land (1 ha)	Variable input (NPK in kg)	Total product (maize in 90 kg bags)	Marginal product (90 kg bags)	Average product (90 kg bags)
1	30	10	0	10
1	60	27	17	13.5
1	90	42	15	14
1	120	56	14	14
1	150	63	7	12.6
1	180	65	3	10.8
1	210	65	0	9.3
1	240	60	-5	7.5
1	270	52	-8	5.8
1	300	42	-10	4.2

NB/ NPK fertilizer is applied in units of 30 kg each. Therefore the average product is obtained by dividing the total product by the units of fertilizer used.

Plot graphs of total product marginal product and average product on the same axis

Zones of a Production Function Curve

The law of diminishing returns helps the farmer to identify the most profitable point at which to produce. If perpendicular lines are drawn through the point where average product equals average product (point where the two intersect), and through the point where the marginal curve intersects the horizontal axis ($MP=0$), the graph is divided into three zones.

Zone I

- In this zone the producer under utilizes the land resource and NPK fertilizer.
- Total product increases at an increasing rate until MP reaches the peak.
- It is not ideal for the farmer to limit production in this zone as the resources can still yield more.
- The zone is referred to as an irrational zone of production

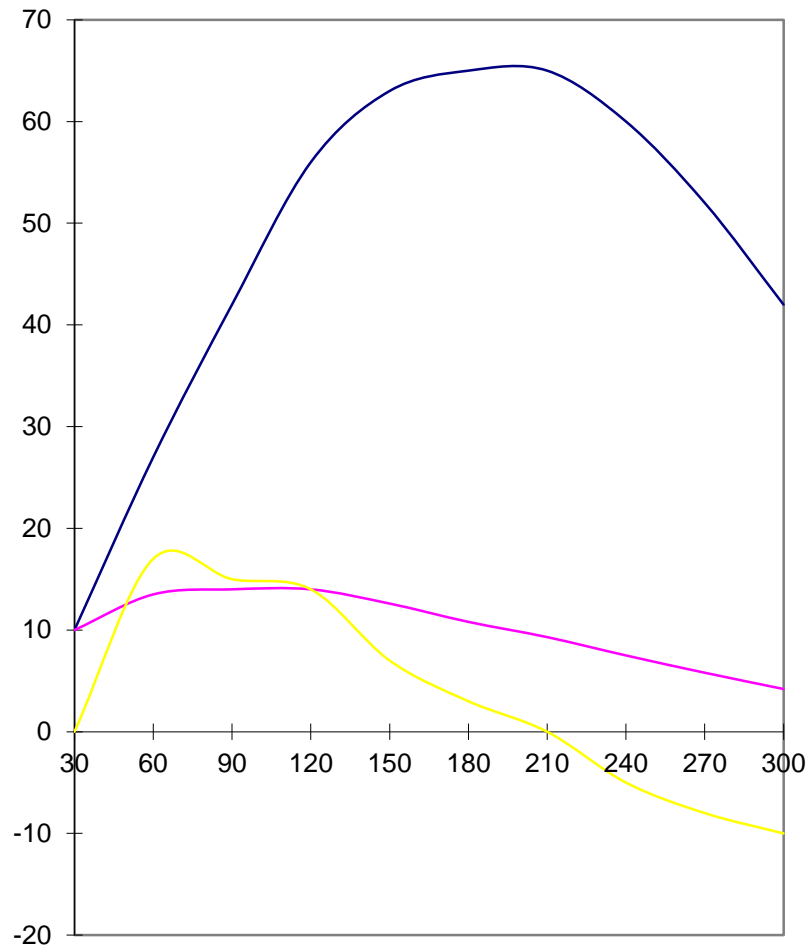

Zone II

- The producer uses the resources to the maximum
- Total product increase at a decreasing rate
- Zone starts where MP starts to decline and ends where $MP = 0$. At this point the AP is at its maximum.
- Therefore AP reaches its maximum when it is equal to the MP
- It is economical to produce in this zone.
- The zone is referred to as rational zone of production.

Zone III

- More application of NPK fertilizer results in the total product declining.
- Marginal product becomes negative

- It's uneconomical to operate in this zone.
- The zone is called irrational zone of production.

2. The Principle of Substitution

- The principle of substitution state that, *if the output is constant, it's profitable to substitute one input factor for another as long it is cheaper than the one being substituted.*
- E.g. Milk production can be maintained constant by substituting dairy meal (less expensive) for dairy cube which are more expensive.
- This principle is based on the concepts of input-input relationships and the product – product relationship
- These concepts enable the producer to substitute a less profitable enterprise with one which is more profitable.

Input-input Relationship

This is the way inputs are combined in production to maximize profit.

Inputs may be combined as follows

1. *Fixed proportions.* In this method of combination there is no substitution. Both inputs must be present in the same proportions.
2. *Constant rate of substitution.* Input factors substitute one another at a constant rate for each level of output regardless of the ratio of the two factors used. This is called perfect substitution. E.g. maize and sorghum as livestock feeds.
3. *Varying rate of substitution.* The factors substitute each other at varying rates. It is the commonest form of substitution in agriculture e.g.
 - i. Hay and grain in feeding livestock
 - ii. Poultry manure and nitrogenous fertilizers
 - iii. Homemade feed rations against commercial livestock feeds.

Product- product Relationship

This is the combination of enterprises with the aim of maximizing the revenue. The following are examples of product – product relationships.

A) Joint Products

This is a situation where a farmer ends up getting other products in the process of producing another product. For example;

- Wool and mutton
- Cotton lint and cotton seed
- Beef and hides
- Mutton and skin
- Milk and butter
- Honey and wax

B) Competitive products

In this case when the production of one product is increased, the production of another is reduced. This occurs where the available resources are limited. e.g.

- Wheat and maize – if wheat acreage is increased, the maize acreage is reduced.
- Dairy and beef cattle – if the number of beef cattle is increased that of the dairy animals is considerably reduced.

C) Supplementary products

This is a situation whereby one product may be increased without decreasing the other. It occurs where the available resources are not fully utilized. Examples

- Introducing a poultry enterprise to supplement other enterprises

- Growing an intercrop between the rows of main crop such as beans in maize plantation

D) Complementary products

This is where an increase in the production of one product increases the production of another simultaneously. E.g. a farmer can introduce a pig enterprise which will be maintained by by-products of grain.

3. The Principle of Equi-marginal Returns

It states, *the limited resources should be allocated in such a way that the marginal return to those resources is the same in all the alternative uses to which they are put.*

This principle is used along with the principle of opportunity cost in the process of maximizing profits.

4. The Principle of Profit Maximization

This is based on the concepts of cost and revenue.

i) The concept of cost

Cost is the price paid for goods used and services rendered in a production process.

The cost of production is quantity input factor used multiplied by the price of each unit of input factor.

$$\text{Production cost} = Q_x \times P_x$$

Where Q = Quantity

P= Price

X= Input factor

The role of cost in production

1. They are used to calculate the gross margins
2. They help to establish the most profitable level of production once they are expressed in monetary terms.

3. Cost influences the quantity of a particular product being produced i.e. the costs incurred during the production period influence the quantity of the product obtained.

Types of cost

1. *Fixed cost (FC)*. These are input costs that do not vary with the level of production. They include rent, salaries of permanent labour, depreciation of farm machinery, buildings etc.
2. *Variable costs (VC)*. These vary with the level of production. They include costs of feeds, fertilizer, fuel and wages of casual labour.
3. *Total cost (TC)*. This is the sum of the FC and VC. $TC = FC + VC$
4. *Average cost (AV)*. This is the total cost divided by the number of units of inputs. $AC = TC/Y$ where Y is the number of units of input.
5. *Average Variable Cost (AVC)*. This is the total variable cost divided by the total output. $AVC = VC/Y$
6. *Average fixed cost (AFC)*. This is the total fixed cost divided by the total output. $AFC = FC/Y$
7. *Average total cost (ATC)*. This is the sum of average variable cost and average fixed costs. $ATC = AFC + AVC$
8. *Marginal cost (MC)*. This is the extra cost incurred in the production of an additional unit of output.

$$MC = \frac{\Delta VC}{\Delta Y}$$

$$\Delta Y$$

Where Δ = change

VC= variable cost

Y= output

NB/ All the costs are defined in terms of units of output and not in terms of units of inputs.

ii) *The concept of Revenue.*

Revenue is the amount of money realized after the sale of the produce.

Types of Revenue

1. *Total Revenue (TR)*. This is the total physical product multiplied by the unit price of the product.

$R = Q_y \times P_y$ where Q = quantity, P = price and y = output factor.

A farmer harvested 1000 90kg bags of wheat, if the price of a 90kg bag of wheat is Ksh 1500, Calculate his total revenue.

2. *Net Revenue (NR)*. This is the difference between total revenue and the total costs of production. This is the profit. $NR = TR - TC$.

3. *Marginal Revenue (MR)*. This is the extra income obtained from the sale of the additional unit of output.

Concept of Profit Maximization

Where the maximum revenue is obtained, then the profit is maximum at that point. In production the maximum profit is obtained where marginal revenue (MR) is equal to the marginal cost (MC). At this point the net revenue is also at its maximum.

Example

In a maize production project carried out over a period of eight seasons, a farmer used one hectare of land each time and applied various quantities of DSP fertilizer as shown in the table below

DSP fertilizer cost 280/- per 50kg bag.

A 90kg bag of maize was selling at 200/-

DSP fertiliser (in 50 kg bags)	Maize yield (in 90kg bag)	Total revenue (Ksh)	Total cost (Ksh)	Marginal revenue (Ksh)	Marginal cost (Ksh)	Net revenue (Ksh)
0	15.5	3,100	0	0	0	3,100
1	35.6	7,120	280	4,020	280	6,840
2	52.7	10,540	560	3,420	280	9,980
3	68.5	13,700	840	3,160	280	12,860
4	70.0	14,000	1,120	300	280	12,880
5	70.5	14,100	1,400	100	280	12,700
6	70.5	14,100	1,680	0	280	12,420
7	68.5	13,700	1,960	-400	280	11,740

. From the table it is evident that,

- As more units of fertilizer are applied, the net revenue increases to reach the maximum of Ksh. 12,880 at 4 bags of fertilizer.
- At the level of 4 bags of fertilizer per hectare, the marginal revenue is almost equal to the marginal cost. This is the point of maximum profit.

Farm planning

This involves setting objectives or goals and clearly stating and defining how to achieve them on the farm.

The farm manager has to device a working programme that uses the limited resources in the most prudent way in order to maximize profit.

Factors to consider in Drawing a Farm Plan

1. *Size of the farm.* A large farm can hold many enterprises while on a small piece of land only few enterprises can be accommodated.

2. *Environmental factors.* The climate, soil type and topography should be considered when making a farm plan. These determine the specific enterprise to be established on the farm. Topography determines where various enterprises should be located depending on the required drainage.
3. *The current trends in the labour market.* This determines the availability of labour. The cost and requirement of the labour should be put into consideration.
4. *Farmer's objectives and preferences.* The interests of the farmer should be put into consideration. A farmer may decide on what enterprises to keep.
5. *Possible production enterprises.* Enterprises to be established are determined by environmental factors, size of the farm, market and price trends in the market.
6. *Existing market conditions and price trends.* If there are no markets for a particular commodity, the farmer's will not produce it. Most farmers try to time their crops to mature when the prices are high.
7. *Availability and cost of farm inputs.* Farmers prefer enterprises which are easily affordable and whose inputs are readily available.
8. *Government regulations and policy.* There are certain government regulations which control the establishment of some enterprises. It is also prohibited to cultivate near the river banks.
9. *Security.* Certain enterprises must be established near the homestead for security reasons.
10. *Communication and transport facilities.* Some enterprises require good communication network.

Steps in Making a Farm Plan

1. Determining the farm size by surveying and calculating out the acreage.

2. Determining the environmental situation, i.e. Climate, soils and vegetation. This is done to ascertain the possible enterprise on that farm.
3. Determining the farmer's objectives and preferences in order to eliminate undesired production possibilities.
4. Developing a provisional/tentative schedule by listing the selected enterprises and analyzing the types and costs of physical resources required. One enterprise or a combination of enterprises should be selected.
5. Determining the technical feasibility (*practical/able to be done*) of the farm to make it realistic taking into consideration other influences such as government policy.
6. Determining the expected yields and returns of various enterprises.
7. Determining the budget by translating the physical plan into monetary value.
8. Developing a financial flow in order to ensure that it is consistent, workable and desirable.
9. Implementing it.
10. Observe and evaluate the plan in the course of implementation.

NB/. After planning is completed, all the factors of production are organized in such a way that the expected results are achieved.

Farm Budgeting

A farm budget is an estimate of the future expenses and income of a proposed farm plan.

Budgeting is the process of estimating the results of a proposed farm plan. It is the translation of a physical plan into financial terms.

Importance of Budgeting

1. Enables the farmer to predict future returns hence helping him to plan ahead.

2. Helps the farmer in decision making whereby a good budget helps the farmer to avoid over expenditure and impulse buying.
3. Helps the farmer to avoid incurring losses by investing in less profitable enterprises.
4. It ensures periodic analysis of the farm business.
5. Acts as a record and can be used for future reference.
6. It enables the farmers to secure loans from financial institutions such as A.F.C. and commercial banks.
7. It highlights efficiency or weakness in the farm business.

Types of Farm Budgets

- Partial Budget
- Complete Budget

1. Partial Budget

It is the simplest and shows the financial implications of proposed minor changes in the farm. For example, change in the size of dairy herd, change of size of land under a crop and change of production technique.

A partial budget tries to address the following questions.

- What would happen if a farmer expanded an enterprise
- What would happen if a farmer replaced one enterprise with another
- What would happen if a new technique is introduced on the farm such as changing from hand milking to dairy milking or rotational grazing to zero grazing?

In partial budgeting one asks four guiding questions.

1. What extra cost is the farmer going to incur as a result of the proposed change.
2. What revenue is to be foregone as a result of the proposed change?

3. What extra revenue is to be earned from the proposed change?

4. What costs are to be saved if the change is effected?

After getting the answers to these questions, the farmer is able to establish whether the proposed change will result in a gain or a loss.

If the farmer is to gain the change is worthwhile but if he is to lose, the proposed change is discarded and other options are sought.

Example

Mr/Mrs X has 4 hectares of arable land,

- 1.5 ha is under wheat
- 0.5ha under maize
- 0.3ha under fodder crop
- The rest is either under improved grass ley or natural grass

The farmer wishes to know whether replacing 0.3 ha of maize with Irish potatoes the following season will be worthwhile.

- The fertilizer rate would have to be increased from 2 bags per ha for maize to 2.5 bags per ha for potatoes and an extra 40 man days of casual labour per ha.
- Average yields of maize and potatoes are 56 and 90 bags respectively.
- The prices are Ksh 1200 per a bag of maize and Ksh 300 per bag of potatoes.
- Seeds costs are Ksh 1350 per 10kg of maize seeds and Ksh 200 per 50 kg of potato seeds.
- D.A.P. fertilizer cost Ksh 1400 per 50 kg bag.
- Labour is paid at Ksh 150 per man day.
- He would require 10 bags of potato seeds and 1 bag of maize seeds to cover 0.3 of a hectare.

Draw up the partial budget and indicate whether the proposed change is worthwhile.

Partial Budget for Mr/Mrs X's Farm

Debit (-)	Ksh	cts	Credit (+)	Ksh	Cts
1. Extra costs on Potatoes			1. Extra revenue on Potatoes		
i) Fertilizer $2\frac{1}{2} \times 0.3$ X 1400/=	1,050	=	Yield 90 X 0.3 X 300/=	8,100	=
ii) Labour $40 \times 0.3 \times$ 150/-	2,000	=			
iii) Seed 200×10	4,850	=		8,100	=
SUB-TOTAL			SUB-TOTAL		
2. Revenue foregone	13,440	=	2. Costs saved	1,350	=
Maize yield $56 \times 0.3 \times$ 1200	18,290	=	Maize i) Seeds 1×1350 ii) Fertiliser $2 \times 0.3 \times$ 1,400	850	=
				10290	=
TOTAL			TOTAL		

Therefore (extra revenue + costs saved) – (extra cost + revenue foregone) is

$$10,290 - 18,290 = -8,000/=$$

-8,000 indicate a loss and therefore the proposed change is not worthwhile.

2. Complete Budget

When proposed changes in the farm are major, or a new farm is being planned for, a complete budget is mandatory. Unlike the partial budget which only deals with variable inputs, a complete budget considers both variable and fixed costs.

Guidelines to follow when carrying out complete Budgeting

1. *Formulation of the farming goals.* The farmer states the reasons for setting up the farm business.
2. *Taking the farm inventory.* Farm buildings, breeding stock, human labour, sources of power machinery and farm equipment are some of the things to include in the inventory i.e. all the assets in the farm.
3. *Planning for resources.* This shows how the resources such as the land, labour and capital are utilized.
4. *Estimating production.* From such enterprises such as crops, animals and other activities.
5. *Estimating the income and expenditure.*
6. *analyzing the input-output relationships that exist on the farm*
7. *Analyzing existing production weaknesses in the farm.*
8. *Making a number of alternative farm plans and choosing one for adoption.*
9. *Putting the best chosen plan into operation and supervising its implementation.*

An example of complete Budget for two hectares mixed farm.

Enterprise	Acreage	Gross margins in Ksh.
i) Maize	0.5 ha	3,000

ii) Irish potatoes	0.5 ha	2,500
iii) Beans	0.5 ha	4,500
iv) Onions	0.25 ha	2,800
v) 100 laying hens	0.25 ha	15,000 27,800

Gross margins are obtained by deducting the total variable costs from the total revenue of each enterprise.

I.e. Gross Margin = Total Revenue – Total Variable cost

Fixed costs

- Labour - one regular hired worker p.a.
4,800.00
- Depreciation of poultry house built at 28,000 over 15 years
150.00
- Cost of hand tools and equipment
1,000.00

Total fixed cost **5,950.00**

Farm profit = Total Gross Margin – total Fixed Cost
= 27,800.00 – 5,950.00
= 21,850.00

Agricultural Support Services Available to the Farmer

1. Extension and Training.

This involves giving informal education to the farmers on production techniques. The Ministries of Agriculture and Livestock Development have extension officers who give these services to the farmers through seminars, short courses, field days, training and visits, demonstrations, chief's *barazas* etc. BAT Kenya Limited, Kenya Breweries Ltd, Church organizations and other N.G.O's also provide extension services.

2. *Artificial Insemination (A.I) Services*
3. *Veterinary services.* Veterinary officers help the farmers in treating and controlling livestock diseases and parasites.
4. *Farm input supplies.* Some cooperatives and private companies supply farm inputs to the farmers. Kenya Farmers Association is an organisation involved in such activities.
5. *Banking.* A farmer requires banking services. Farmers can open a *current account* or a *savings account* with banks.

Current Account

It's a bank account from which cheques are paid. Money in such an account does not earn interest.

A Savings Account

This account earns interest but cheques cannot be drawn on it.

Advantages of using banking services

- a) The farmer's money is safer in the bank.
 - b) Cheques can be used as evidence of payment in case of a dispute.
 - c) Writing a cheque is easier than counting huge sums of money.
 - d) Farmers with bank accounts can get overdrafts where current account holders are allowed to withdraw more money than what is in the account or loans.
 - e) The bank gives advice to farmers on how to use the credit given for maximum results.
 - f) A banker's statement acts as an evidence of a farmer's financial worthiness when he wants to acquire or lease some property.
6. *Credit.*

Since capital is a limited resource, farmers can overcome this limitation by borrowing capital. Borrowed capital is called credit or loan. The farmers pay it back with an interest. The loan is given against such collateral as land title deed, buildings and machinery.

Types of Credit

- Short term Credit. Given as working capital such as seeds, fertilizer and feeds. It's repayable within one year. AFC gives farmers short term credit.
- Medium term Credit. Repayable within 5 years and is used for farm development projects such as fencing, buying machinery, soil and water conservation and buying livestock.
- Long term credit. Repayable within a period of 15 years. It's used for improvement of projects such as soil conservation, building and construction, establishing permanent crops etc.

Credit can be termed as *soft or hard*. Hard loan is given against security such as machinery and land while soft is given with little or no security.

Sources of Agricultural credit

- *Cooperative societies*. They give credit to farmers. Their interest rate is lower than that of commercial banks.
- *Crop boards*. Some crop boards give credit to farmers and recover their money through deduction made on farmers pay out. E.g. Pyrethrum Board of Kenya and the National Irrigation Board.
- *Commercial banks*. They advance short term to medium term loans to farmers which are paid back with an interest that is slightly higher.

- *Agricultural Finance Corporation*. They give short term to long term credit to farmers. Their interest rates are low.
- *Settlement Fund Trustees*. They lend short term to long term credit to new settlers in settlement schemes.
- *Others*. Hire purchase companies, individuals, insurance companies and traders.

7. **Agricultural Research.**

- The main objectives of agricultural research are;
 - i) Improve crop and livestock production techniques.
 - ii) Develop improved varieties of crops and livestock.
 - iii) Improve pastures and fodder quality.
 - iv) Develop techniques of controlling diseases and parasites.
 - v) Determine suitable ecological zones for various crops.
 - vi) Coordinate research work being done throughout the country to avoid any duplication.
- Examples of agricultural research stations in Kenya.
 - i) Coffee Research Station in Ruiru. - **Coffee**
 - ii) Kenya Agricultural Research Institute (KARI) at Muguga - **Agronomy, plant pathology, entomology, forestry etc.**
 - iii) Kenya Agricultural Research Institute (KARI) at Kitale. – **Maize and pasture crops.**
 - iv) National Plant Breeding Station at Njoro. – **Wheat, barley, sunflower etc.**
 - v) Pyrethrum Research Station at Molo. – **pyrethrum**
 - vi) Horticultural Research Station at Thika. – **fruits, cut flowers, pulses etc**
 - vii) National Sugar Research Station at Kibos.
 - viii) Tea Research Foundation at Kericho.
 - ix) Dryland farming Research Station at Katumani in Machakos. – **plant breeding pest management, animal nutrition.**

- x) National Agricultural Laboratories at Kabete – **entomology and soil testing.**
- xi) Sunflower Research Station at Wanguru near Embu.
- xii) International Centre for Insect Physiology and Ecology (ICIPE) at Nairobi and Mbita.
- xiii)** Western Agricultural Research Station in Kakamega which deals **with research of on sweet potatoes, cassava and small ruminants.**
- xiv)** National Animal Husbandry Research station at Naivasha. - **Livestock breeding and management**
- xv) Veterinary Research Station at kabete.
- xvi)** Coast Agricultural Research Station at Mtwapa which conducts **research on maize and sugarcane.**
- xvii) Cotton Research Station at Kibos Kisumu.
- xviii)** Embu Research Station. – **Medium altitude maize varieties.**
- xix) International livestock Research Institute (ILRI) in Nairobi.

8. Marketing.

- The following are some organizations that market farmers produce.
 - i)** National Cereal and Produce Board.(NCPB) – **maize, wheat and pulses e.g groundnuts, beans, green grams etc.**
 - ii) Kenya Cooperative Creameries.(KCC) – **milk**
 - iii) Kenya Planters Cooperative Union (KPCU) - **Coffee**
 - iv) Pyrethrum Board of Kenya. – **pyrethrum**

9. Tractor Hire Service.

This involves hiring of tractors and implements by farmers who don't have them. The following offer these services.

1. *Government Tractor Hire Service.* This is under the Ministry of Agriculture. Farmers hire implements and

tractor if they do not have them. These services are available in almost all districts. The service is relatively cheap but farmers rarely get the services when they need them because of high demand.

2. *Private Contractors.* These are either individual contractors or companies who offer these services to farmers. They move from one part of the country to another in search of farmers who would need their services. For example in December to March, there are many contractors in Rift Valley. In August and September, they move to short rain areas. These contractors however charge more than the government but they are more readily available.
3. *Individual Farmers.* Some farmers have tractors for their own personal use. When they have finished ploughing their own land, they let them out for hire. Their charges are negotiable.
4. *Others.* Some cooperative societies own tractors, which they let out for hire to their members. Cooperatives are cheaper than other hire services.

Advantages of Tractor Hire Services.

- Farmers who can't afford to buy a tractor can get access to tractor services.
- Farmers don't incur the costs of servicing and maintenance of the tractor and implements.
- The services are more efficient than hand tools, which is the other alternative.

Disadvantages of Tractor Hire Services.

- They are not available to most farmers when they need it.
- Private contractors and individual farmers may overcharge farmers.

Risks and Uncertainties in Framing

Uncertainty. It is the imperfect knowledge about future events or outcome due to the uncontrollable variables such as weather changes, pest and disease outbreaks and fluctuations in commodity prices.

Risk. This is the divergence between the expected and actual outcome. There is always a difference between what a farmer would predict and the actual outcome.

Types of risks and Uncertainties

- i.) *Fluctuation in commodity prices.*
- ii.) *Physical yield uncertainty.* The farmer is unsure of what to actually expect.
- iii.) *Ownership uncertainty.* Farmer may lose the produce through theft, change in government policy, fire, death etc.
- iv.) *Disease and pest outbreaks.*
- v.) *Sickness and injury uncertainty.* The farmer or member of his family or employee is affected and loses the ability to work due to sickness or injury.
- vi.) *New production technique uncertainty.* The farmer may be uncertain whether new technique is as effective as the previous one.
- vii.) *Obsolescence.* A farmer may invest in machinery, which may become outdated (obsolete) within a short time.
- viii.) *Natural catastrophies.* Things like earthquakes, floods, drought, storms and strong winds may destroy crops and kill animals.

Ways of Adjusting To Uncertainty.

- i.) *Diversification.* This involves having several and different enterprises on the farm so that should one fail, the farmer does not suffer total loss.
- ii.) *Flexibility in production methods.* Farmers may design their enterprises in such a way that, should there be a need to change from one enterprise to another, they can

- do so with minimal expenses. For example livestock buildings should be designed in such a way that they can be modified to accommodate any type of animal as need arise.
- iii.) *Input rationing.* Farmers may apply fewer inputs than the optimum required for an enterprise to reduce more losses in case of any unexpected variable. Additional inputs can be used in enterprises with better chances of giving more returns.
 - iv.) *Insurance.* Insuring the enterprises guarantees farmers compensation in the event of loss. This covers losses due to crop failure, death of livestock, theft, fire, and accidents in farm machinery.
 - v.) *Contracting.* Farmers may enter into contracts with consumers to supply specified goods for a certain period of time at an agreed price. E.g Tobacco farmers with BAT Kenya Ltd., barley farmers with EABL. Pig farmers with Farmers Choice etc.

Advantages

This ensures a constant, fixed market for their produce.

- Should prices fall, the farmer gains as he continues to supply the produce at the contracted price.

Disadvantages

- Contract prices are usually lower than the average market prices hence farmers get lower incomes in the long run.
 - Should market prices rise, the farmer would not benefit as their price is already agreed on.
- vi.) *Selecting more certain enterprises.* A farmer should try to select an enterprise that earns a steady income though less profitable than choosing one that has a high variation income realization.

vii.) *Adopting modern production methods.* They include, irrigation, spraying crops against pests and diseases, vaccinating animals against diseases etc.

Government role in minimizing risks and Uncertainty

- *Weather forecasting.* This helps farmers to prepare land and plant at the right time.
- *Research and extension.*
- *Subsidizing of input prices.*
- *Market regulation.* This protects the farmer from exploitation.

AGRICULTURAL MARKETING AND ORGANISATIONS

Market and Marketing

Market:

- Is an institution for exchange of goods and services.
- Is a place where buyers and sellers carry out business transactions or
- Is a group of buyers and sellers in sufficiently close contact with one another for exchange to take place between them.

Perfect market	Imperfect market
Any buyer can purchase from any seller	Some buyers or sellers or both are not aware of the prices offered by others.

Types of market structure

- i) Monopoly; A single seller may dominate the market but many consumers or buyers in the market.
- ii) Oligopoly: few sellers or firms with mutual interdependence.
- iii) Monopsony: one buyer and many sellers of a specific commodity.
A sole buyer exists in the market.

Sellers may lower the price below the expected fair price.

Marketing/ Marketing functions:

-Are all the activities and services which are associated with the flow of goods and services from production to consumption.

A service is a function which alters a commodity in form, place, time or possession to increase the value of a product.

Marketing Functions and Services

Describe the marketing functions of agricultural commodities. (10 mks)

a) Buying and Assembling

Buying: Is the acquisition of goods from the farmers on payment of cash.

Assembling: Collecting of produce from the farms and concentrating at stores by private traders or marketing boards.

b) Transporting and distribution: Through air, water, rail, or road by middle men.

c) Storage: storage varies with the product and the climatic environment e.g. meat is stored in cold stores, eggs under oil or water glass coatings which seal the shell to prevent deterioration. Storage makes goods available throughout the year.

d) Packing: Materials include; baskets, sacks, milking cans and churns, cardboard box, containers etc. prevents the produce against damage, theft and adulteration on its way to the market. It also facilitates measurement.

e) Processing: Changes the original forms of goods e.g. meat animals—slaughtered, dressed and chopped. Milk—pasteurized, bottled, buttered, cheesed.

f) Grading and Standardization: Grading: Sorting out of produce into different lots considering market quality, bearing label and name e.g. on size, shape, colour, ripeness flavor, length and other measurable features that

affect value. Purpose: --Is to select desirable quality produce and avoid time wastage at inspection.

Standardization: Establishing uniformity in quality and quantity of products. Purpose: increase buyers' satisfaction, establish criteria for inspection, ensure safety and avoid exploitation of consumers.

g) **Packaging:** comes after processing.

Purposes:

- Enables handling of produce.
- Makes marketing more efficient.
- Prevent physical deterioration, theft, tampering, adulteration and substitution.
- Offer easy labeling.
- Measurement.
- Attachment of sales description and instructions.
- Promote sales or advertise.

h) **Collecting market information or market research:**

- Provide knowledge of supply and demand.
- Determine where and when to sell.
- Determine quality of commodity needed
- Determine prices in alternative markets.

i) **Selling:** Presentation of produce to consumers. Involves advertising, displaying of the produce in the market and bargaining for fair prices. Do not overcharge or under charge.

j) **Financing:** Capital is required from buying raw produce to final sale of finished goods.

k) **Bearing of risks/uncertainties:** Include destruction by fire, theft, physical deterioration in quality, fluctuation of prices and change in tastes e.g. by transferring them to insurance companies.

Marketing Organizations and Agencies

Describe various agents and organizations that are involved in the marketing of coffee (10 mks)

These are bodies which facilitate the marketing process.

Include:

- 1) **Wholesalers;** Buy goods from producers , processors or manufacturers in bulk and sell to retailers and other merchants and consumers in relatively large or small lots.
Have transport facilities. Have large storage depots.
Bear marketing risks. Speculate on goods moved to the market. Arbitrage:- Buy when and where prices are low and sell when/where prices are high.
- 2) **Retailers:** Buy in bulk from wholesalers or processors and sell to consumers in small quantities.
- 3) **Itinerant traders/ middlemen:** Are middlemen who buy in small bits, assemble, transport and sell to town markets.
- 4) **Packers and Processors:** Are industries which change the form of produce e.g. Unga limited, B.A.T, Delmonte and sugar companies.
- 5) **Commission Agents:** Are middlemen who act on behalf of the other businessmen for a fee or a commission. Do not own any commodity.
- 6) **Broker Agents:** act on behalf of the sellers or do not actually handle the goods but have a good knowledge supplies of the same i.e. requirements and prices.
- 7) **Co-operative societies and unions:** Help farmers to market their produce locally and internationally e.g. k.c.c. reduce market costs for small scale farmers.
- 8) **Marketing Boards:** Assists in the production of agricultural commodities. Also store, sell, buy, and collect agricultural commodities.

9) Auctioneers: Concentrate buyers and sellers at a particular place and time where they negotiate on purchases and sales. Take a % commission on sales.

Special Characteristics of Agricultural Products

- **Bulky:** Occupy large weight and volume.
- **Perishable:** Cannot stay long without suffering loss and deterioration in quality

Problems in marketing agricultural products

Describe the problems encountered by farmers when marketing agricultural produce e.g. tomatoes (10 mks)

a) Perishability: e.g. fruits, vegetables, milk, meat etc go bad very quickly.

Prevention

- Store under refrigeration.
- Sell immediately.
- Process into other forms.
- Can or dehydrate e.g. fruits, vegetables. Prevention is expensive hence increase marketing costs.

b) Seasonality: Products are only available in plenty at harvest periods.

- This affects market prices and creates storage problems.
- Supply is inelastic due to long waiting periods.
- There is uncertainty on price expectation.

c) Bulkiness: Products weigh heavily, occupy large space and have low value per unit weight. This poses problems on storage, transportation and increases price of produce beyond buyers ability.

d) Storage: Construction of storage facilities is expensive thus increasing the cost of marketing.

e) Poor transport system: poor roads in rural areas and inadequate means of transport. Farmers fail to take produce to the market. Perishable products get spoiled.

- f) Change in market demand:** The long time lag between the decision to produce and the actual availability of the product changes the consumers taste and preferences affecting demand and price.
- g) Limited elasticity of demand/Inelastic demand:** Sometimes there is more quantity supplied which may lead to low demand and therefore low price for the produce i.e. excess supply that leads to low demand and low price.
- h) Lack of market information:** This is due to low state of knowledge. This makes the production not to be in close conformity with market demand. Middlemen exploit them by buying produce at very low prices and sell at high profit margin.
- i) Changes of supply /Inelastic supply:** Sometimes there is overproduction or under production of goods. This leads to fluctuation of market prices.

Efficiency in marketing/How to increase profits

- a) Minimize total costs of the whole process.
- b) Timeliness of the product assembly and delivery.
- c) Maintenance of the product quality.

Price theory

Price: Is the amount of money paid in exchange of good or service.

-Is affected by demand, supply and the quality of good or service.

The law of demand and supply:

Demand: Quantity of goods or services consumers are willing and able to buy at each specific price in a given market at a given time.

Demand is low when the price of goods is high and vice versa. Relationship between demand and price

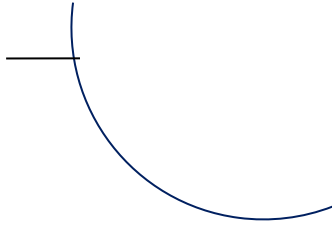

Terms used in demand

- Want- Desire to have a good.
- Demand- Ability to purchase that good at a given price.
- Utility- Property of a product that makes it satisfies a want (desire).
- Effective demand: type of demand which involves payment for the required goods and is determined by one's income.
- Law of demand: The quantity of a good or service demanded varies inversely with the price, or the higher the price, the less the quantity demanded and the lower the price, the more the quantity demanded.
- Demand schedule: List of quantities a given population will buy at different prices.
- Individual demand: A list of quantities or products that a person will purchase at various prices.
- Total demand: total of individual demands of a product.
- Demand is mainly determined by price but sometimes it can change if the price is constant due to other factors.

Change of demand at a constant price.

Factors influencing demand for a commodity

- a) Population:** A change in the number of consumers in a market influences the total demand for goods and services. If population increases, the demand for a given good or service at a given price increases and vice versa.
- b) Income:** Consumers with a higher income buy more than those with low. As income rise, demand for some foods like meat, butter, rice, grape fruit etc rice.

- c) Preference and taste:** Demand changes with changes in tastes and preferences by consumers.
- d) Prices of related goods:** Demand of a commodity increases if there is an increase in the price of a substitute e.g. Margarine demand increases if the price of butter increases.
- e) Advertisement:** Promotes the sale of a commodity thereby increasing its demand because customers become aware of the existence of the commodity.
- f) Beliefs, customs and taboo:** Influence total demand for a given good or service e.g. pork among Muslims.
- g) Price expectation:** If in future the prices of a certain commodity are likely to go up, then the demand of that commodity increases currently or vice versa.
- h) Level of taxation:** Increase in taxes increases the prices of certain goods and fewer people can afford them. This reduces demand.
- i) Perishability:** when goods like milk, eggs, meat, tomatoes and fruits deteriorate in quality, demand falls due to loss of freshness.
- j) Future expectations or uncertainty;** Fear of shortage of a commodity in future, consumers buy more for stocking thus increasing demand.

Elasticity of demand (ED)

Ed- Is the degree of responsiveness of demand to change in price or the amount of change in the quantity of a product that the consumers will buy in response to a given change in price.

Calculation of Ed

$Ed = \frac{\% \text{ change in quantity demanded}}{\% \text{ change in price}}$

Example

The elasticity of demand when 1000 loaves of bread are demanded at a price of ksh. 20 per loaf while only 600 loaves were demanded at ksh. 23 per loaf is:

$Ed = \frac{\% \text{ change in quantity}}{\text{original quantity}} \times 100$

$$\begin{aligned}
&= 1000-600 \times 100/600 \\
&= 400 \times 100/600 \\
&= 66.6\%
\end{aligned}$$

$$\begin{aligned}
E_d &= \% \text{ change in price} / \text{original price} \times 100 \\
&= 20-23 \times 100/23 \\
&= -3/23 \times 100 \\
&= -13.04\%
\end{aligned}$$

$$\begin{aligned}
E_d &= \% \text{ change in quantity} / \% \text{ change in price} \\
&= 66.6 / -13.04 \\
&= 5.11
\end{aligned}$$

N.B the -ve and +ve sign of E_d is ignored.

The figure obtained gives the type of E_d e.g.

- a) Elastic if more than 1.
- b) Unitary if equal to 1.
- c) Inelastic if less than 1.

1. Elastic demand
2. Inelastic demand
3. Unitary elasticity

Factors that determine the elasticity of demand

- a) The availability of substitutes;** Commodities with many substitutes have an elastic demand although salt with no substitute has an inelastic demand and therefore has to be bought at any price.
- b) Degree of necessity:** Salt or food of great necessity have inelastic demand and have to be bought at any price. Luxury commodities have to be forgone in case of increase in price.
- c) The number of uses a product can be put to:** Commodities with several uses have elastic demand.
- d) Time lag:** If the use of a commodity can be postponed to another day then it has elastic demand e.g. cement for construction.

e) Time span: There is greater E_d in the long run because adjustments can be made while a smaller E_d in the short run since it is difficult to vary some factors.

f) Proportion: Commodities with large proportions of total expenditures e.g. animal feeds and fertilizers have elastic demand while those with very small proportion have inelastic demand.

Supply

Is the quantity of goods or services which producers or sellers are willing to sell at each specified price in a given market and time.

Law of supply: As the price of goods and services increase, the corresponding quantity of goods and services offered for sale increases and vice versa.

The relationship between price and supply

Change of supply at constant prices

Supply schedule: --Is a list of quantities of an item that will be produced or sold at all probable prices.

A supply schedule for meat:

Price of meat per month (ksh.)	Quantity of meat supplied in kg.
25	80
20	70
15	50
10	20
5	10

Factors influencing supply of a commodity

- 1. Number of sellers in the market:** Many sellers increase the supply of goods and services.
- 2. Prices of related goods:** Supply is low if the price of a related good is higher e.g. If the bread price increases its supply is higher but supply of cakes decreases.

3. **Price expectation:** supply is low now if in future the supply is expected to rise.
4. **Technology:** Lead to increase of production of goods.
5. **Weather:** Increase in production of goods when the weather is favorable.
6. **Government policy (taxation):** Increases in tax of inputs, increase price of commodities produced, thus the farmers drop the production of the produce.
7. **Change in prices:** Increase in price lead to increase in supply of the good because of the high profit earned.
8. **Cost of production:** If the cost of fertilizers and seeds is low, farmers supply more of this, in turn increase the yields.
9. **Increase in supply of associated goods:** increase the supply of the other good e.g. increase in meat supply increase in hides and skins.
10. **Transportation system:** Improved and efficient transport system, increase delivery and supply of farm produce.

Elasticity of supply (E.S)

Is the degree of responsiveness of supply to changes in price.

ES = % change in quantity supplied / % change in price

Example: If the price of millet changes from ksh. 10 to ksh. 12 per kg. Resulting to a change of supply from 400kg to 600 kg, calculate the elasticity of supply.

$$\begin{aligned} \text{\% change in supply} &= \frac{600-400}{400} \times 100 \\ &= \frac{200 \times 100}{400} \\ &= 50\% \end{aligned}$$

$$\begin{aligned} \text{\% change in price} &= \frac{12-10}{10} \times 100 \\ &= \frac{2 \times 100}{10} \\ &= 20\% \end{aligned}$$

$$\begin{aligned} \text{E.S} &= \frac{\text{\% change in quantity supplied}}{\text{\% change in price}} \\ &= \frac{50}{20} \\ &= 2.5 \end{aligned}$$

Types of E.S

1. Elastic if more than 1
2. Inelastic if less than 1
3. Unitary if equal to 1

Determination of market price

When price is high P2, supply is high Q4 but demand is low Q2.

When price is too low P1, the supply is also low Q1, but the demand is high Q3.

P1 has to be raised for the suppliers to sell more goods and P2 has to lower to satisfy the demand.

The resultant price P, where quantity of goods supplied is equal to the quantity of goods demanded is known as **equilibrium or market price.**

No competition of suppliers and consumers. Both parties are satisfied. This situation only exists in a free market.

Price control:

1. Government gives subsidies by reducing the cost of production of inputs.
2. Government fixes the prices of related goods.

Agricultural Organisations

Agricultural organization is any body which promotes agricultural activities.

Include:

- 1. Co-operative societies:** Is an organization of people who have joined together voluntarily with a common purpose for a mutual economic benefit.

Types of co-operative societies

- i) Farmers or producer:** Formed by farmers with limited capital to viably stand by their own. They buy large lands and each farmer is paid dividends per his shares.
- ii) Consumer:** sell farm inputs to farmers. Buy inputs in bulk and sell at lower prices to farmers.

iii) Marketing; Formed by small scale farmers to market their produce collectively. This reduces costs.

iv) **Savings and credit:** Give loans to farmers.

a) Formation of co-operatives:

Steps followed:

- A minimum of 10 adults are required.
- Interested people form an interim committee.
- Name is decided.
- Members draw up a constitution.
- They work with the local co-operative officer.
- Seek for registration with the commissioner for co-operatives.

b) Principles of co-operatives:

- i) **Open membership:** Joining is voluntary after paying membership fee regardless of race, religion, sex, education and political inclination so long as are adults with a sound mind.
- ii) **Equal rights:** one man one vote operates.
- iii) **Principle of share limit;** Members buy shares up to a specific maximum limit to avoid domination by one member.
- iv) **Interest on shares:** Money accruing capital provides dividends on basis of share contribution.
- v) **Withdrawal from membership:** Members withdraw voluntarily.
- vi) **Loyalty:** Members are faithful and loyal to their co-operative e.g. Members must sell their produce through their co-operative.
- vii) **Education:** Members are educated to be knowledgeable on relevant skills and conversant with co-operative affairs.
- viii) **Co-operative principle;** the co-operatives should join co-operative movements at primary, district, national and international levels.

- ix) **Non-profit motive:** Co-operatives are essentially non profit making organizations. This objective improves the living standards of members.

c) Functions of co-operative societies:

- Marketing or selling farmers produce.
- Negotiate for fair prices for inputs and produce.
- Keep records of co-operative activities and inform members accordingly.
- Pay dividends to members.
- Give loans/credit in kind to members.
- Educate members on relevant co-operative matters.
- Provide/distribute inputs at subsidized prices.
- Some process inputs.
- Provide extension and machinery services.
- Some provide banking services to members.
- Some invest money on behalf of farmers.
- Advise members on new and better methods of production.

2. Agricultural parastatal bodies: Are bodies established by acts of parliament.

Include: boards, commissions, authorities and corporations.

a) National irrigation board. Develop and improve irrigation projects e.g. mwea tembere, Ahero, west kano, perkerra etc.

**b) National Cereals and Produce Board:
Functions**

- Regulate and control production and storage of cereals and pulses.
- Buy and store cereals.
- Advise the minister on production, importation and exportation of produce.

c) The Kenya sisal board

Functions

- Promote sisal production.
- Regulate production, grading and marketing.
- Register sisal producers.
- License sisal factories.
- Examine export to ensure and maintain high quality.
- Re-bale sisal.

d) Coffee Board of Kenya.

Functions

- License coffee producers and processors.
- Carry out research on production and processing.
- Negotiate for fair prices and quotas.
- Market parchment coffee.

e) Pyrethrum Board of Kenya

Functions

- Advise farmers.
- Manage pyrethrum nurseries.
- Process pyrethrum in factories.
- Market processed products.
- Buy pyrethrum from farmers.
- Research to obtain best cultivars through selection and breeding.

f) Cotton Board of Kenya.

Functions

- Plan, monitor, regulate cotton growing and ginning.
- License and control cotton ginneries.
- Regulate and control quality of raw cotton.
- Regulate export and import of cotton lint/seed.
- Regulate and control seed supply and quality.
- Promote research, production and processing.
- Provide and co-ordinate training for industry sectors.

g) Kenya Sugar Authority.

Functions

- Advise on development of sugarcane production for manufacture of white sugar.
- Advise on rules and regulations for development of sugarcane in industries.
- Formulate and advice on sugarcane prices.
- Advice on research.
- Develop and implement cane testing services and quality.
- Advise on processing.
- Register producers.
- Ensure availability of statistics.
- Advise on utilization of sugarcane produce.

h) Horticultural Crops Development Authority.

Functions

- Offer advisory services.
- Collect produce from farmers.
- Sort and grade produce.
- Market produce locally and abroad.

i) Agricultural Finance Corporation.

Functions

- Provide credit at reasonable interest rates.
- Provide technical services to farmers e.g. on borrowed capital.
- Ensure loan repayment.

j) Agricultural Development Corporation.

Functions

- Run and operate state farms..
- Raise high quality livestock which are sold as breeding stock.
- Bulk planting materials.
- Promote agricultural production.

K. Kenya meat Commission.

Functions

- Buy cattle from beef farms.
- Slaughter beef.
- Grade carcasses.
- Market beef locally and overseas.

Other Farmers organizations

1. Kenya National farmers Union

Functions:

- Bargain for fair prices of produce.
- Ensure supply of farm inputs.
- Bargain for reasonable and affordable prices of farm inputs.
- Provide better infrastructure.
- Provide loan.
- Control pests and diseases.
- Market produce locally and abroad.
- Offer technical services.
- Represent farmers in international federation of agricultural producers.
- Publish a monthly magazine—“Farmers Voice”.

2. Agricultural Society of Kenya.

Functions:

- Hold competitive agricultural shows and exhibitions.
- Encourage breeding and importation of pure breeds.
- Encourage and assists in official milk recording scheme.
- Organize the running of YFC.
- Organize national ploughing contest.
- Publish Kenya stud book.
- Publish monthly journal—Kenya Farmer.
- Award bursaries for local and overseas studies/tours for its members.

3. 4-k clubs; kuungana, kufanya, kusaidia, Kenya.

For primary school members.

Functions

- Carry out practical projects show agriculture is a profitable profession.
- Expose youth to existing improved agricultural technologies.
- Develop and enhance leadership qualities among youth.
- Take part in competitive shows.
- Involvement in field trips.

4. Young Farmers Club

Secondary school and tertiary education members.

Functions

- Participate in exhibitions and competitions at A.S.K shows.
- Involvement in agricultural projects at club levels.
- Participate in YFC annual rallies.
- Involvement in workshops and seminars.
- Participate in national tree planting activities.
- Participate in exchange programmes both locally and abroad.
- Participate in national ploughing contest.

AGRICULTURAL ECONOMICS IV

(FARM ACCOUNTS)

Importance of Keeping Farm Accounts

- **They help the farmer to:**

- i). Secure loans.
- ii). Make sound management decisions.
- iii). Determine whether the farm is making profit or loss.
- iv). Evaluate assets and liabilities.
- v). Prepare farm budgets.
- vi). Assess the tax a farmer is to be charged.

FINANCIAL DOCUMENTS

- **They include the following;**

- i). *Invoice.*

- It is commonly used in business when goods are delivered on credit.
- It is issued to inform the buyer of the goods delivered and debits the buyer. It contains the following details.
 - ✓ Date of the transaction.
 - ✓ Type and quantities of goods delivered.
 - ✓ Price per unit of the goods.
 - ✓ Total amount of money involved.
 - ✓ Serial number of invoice.
 - ✓ Terms of payment.

- ii). *Statements.*

There are two types of statements, these are;

- **Statements of account.** This is a document sent to the buyer by the seller as a reminder to inform him what he owes the seller. Usually it is written at the end of the month.
- **Bank statements.** This is a financial document sent by the bank to the farmer on a monthly basis showing the position of the bank account by the end of the month.

- iii). *Receipt.*

- This is issued when cash payment for goods delivered or services rendered is made. It is issued by the seller to the buyer.
- It contains the following details.
 - ✓ People involved in the transaction.
 - ✓ Date of payment.
 - ✓ Goods or services for which payment is made.
 - ✓ Amount of money involved.
 - ✓ Signature of person receiving the money.
 - ✓ Receipt serial number.

- iv). *Delivery note.*

- This document accompanies goods on delivery. It is evidence that good have been physically delivered from the supplier to the buyer after a credit transaction.
 - It contains the following details.
 - ✓ Date of delivery.
 - ✓ Quantity of goods delivered.
 - ✓ Method of delivery.
 - ✓ Person who receives the goods.
 - ✓ Condition in which the goods are received.
 - ✓ Delivery note serial number.
- v). *Purchase order.*
- This is a request to a trading business firm to supply specified goods. It may be accepted or rejected by the supplier of goods.
 - Purchase order specifies the following;
 - ✓ Type of goods required.
 - ✓ Quantity of the goods.
 - ✓ Date of order.
 - ✓ Person who orders the goods.
 - ✓ Person who authorizes the order.
 - ✓ Date within which the order goods should be delivered.
 - ✓ Serial number of purchase order.

BOOKS OF ACCOUNTS.

a) Ledger.

- ✓ This is the principal or main book used in keeping financial records.
- ✓ It contains the details of all the things in the business owned by the farmer.
- ✓ All accounts are kept in the ledger.
- ✓ An account is a page or a section in the ledger given to a person or a firm on which all the business transactions relating to that person/firm are entered.

- ✓ In the ledger page, the account is divided into two parts drawn in the shape of letter T.
- ✓ The name of the heading for the account is written on the top line (above the horizontal line).
- ✓ Left hand side of the account is the debit side (DR) where all the decreases (purchases and expenses) are recorded.
- ✓ The right hand side is the credit side (CR) where all the increases (Sales and receipts) are entered.

A Ledger Account page.

Dairy Cattle.

DR				CR			
Dat	Particular	Foli	Amoun	Dat	Particular	Foli	Amoun
e	s	o	t	e	s	o	t
201			Shs.	201			Shs.
3			cts	3			Cts.
Jan	Bought	3	3,000.	Jan	Sold	3	30,000
1 st	bags of	1	00	6 th	heifers	1	00
	dairy						
	meal						

Use of columns

- i). *Date columns.*
 - The date affecting the account is recorded here.
- ii). *Particulars column.*
 - This is a short description of the entry being made.
- iii). *Folio column.*
 - This is a page where a particular account appears in the ledger. Every page in the ledger is numbered and each account should appear on its own page (folio).
- iv). *Debit side. The following details are entered here.*
 - ✓ Date of the transaction in the date column.
 - ✓ The item in the particulars side.
 - ✓ The folio number of the item in the folio column.

- ✓ Amount of money involved in the amount of column.
- v). *Credit side. The following details are entered here.*
 - ✓ The date of the transaction in the date column.
 - ✓ Cash at hand in the particulars column.
 - ✓ Folio number of cash at hand in folio column
 - ✓ Amount received in the amount column.

b) Inventory

- This is a book in which a record of all the assets owned by a business or an individual is kept.
- Inventory records are divided into two groups as follows
 - i) Consumable goods inventory e.g. seeds, feeds, fertilizers, pesticides, fuel etc.
 - ii) Permanent goods inventory e.g. tools and equipment, machineries, buildings etc.

c) Cash Book

- This is a book in which all the transactions involving the receiving and paying out of cash are recorded.
- It consists of the sales and receipts side, and purchases and expenditure side.
- The following details are entered in a cash book.
 - i) Date of payment.
 - ii) Receipt number.
 - iii) Person/firm from whom money is received.
 - iv) Total amount received.
- The balancing of the cash book is done at the end of the month.

Diagram of a Cash account

Sales and Receipts 2013

**Purchase and Expenditure
2013**

Date Particulars Shs. cts Date Particulars Shs. cts

Jan 1 st	Sale of 2 egg trays	600 00	Jan 2 nd	Bought 70kgs layers mash	2,800 00
------------------------	------------------------	--------	------------------------	-----------------------------------	----------

d) Journal

- This is a book where all unclassified transactions are entered.
- Some of the information that may be recorded in journal include;
 - i) Purchase on credit of a capital equipment i.e. things bought to keep and use and not for resale.
 - ii) Sale on credit of capital equipment.
 - iii) Rectifications of errors for example if errors are made in other books, new entries, correcting or cancelling the old entries are made in the journal.
 - iv) Transfers from one account to another in the ledger.
 - v) Opening entries in new books, when new books have to be opened etc.
- The following details are recorded in the journal;
 - i) Date.
 - ii) Name of the account to be debited.
 - iii) Name of the account to be credited.
 - iv) Amount of money involved
 - v) A brief description of the transaction.

Subsidiary Books of the Journal

a) Purchase Book

- All the details of items bought on credit are entered once.
- It is known as the creditors account. A creditor is someone to whom the farm (business) owes money.

b) Sales Book

- It is known as the debtor's account. A debtor is a person who owes money to the farm business.

- All details of goods sold from the farm for which payment has not been received are entered here.

FINANCIAL STATEMENTS

AIM:

- Determine profit or income.
- Evaluate the properties or assets in the farm.
- Determine the business liability.

INCLUDE:

- Balance sheet:** Is a financial statement drawn to show the financial position of a farm business as at a particular period of the year.

2 types;

- i)** Opening balance sheet: -Drawn at the beginning of an accounting period.
- ii)** Closing balance sheet: - Drawn at the end of an accounting period.

The closing B/s of an A/c period is the opening B/s of the next A/c period.

A B/s has 2 sides:

LHS: Shows liabilities.

RHS: Shows assets.

Liabilities: Are debts e.g.

- Loans and mortgages
- Bank overdrafts.
- Debts payable for goods and services received.
- Services paid to the business in advance.

2 types

- i)** Long term liabilities: Debts repaid in more than one year e.g loans from AFC.
- ii)** Current liabilities: Debts to be cleared or repaid within a period of one year e.g. rent, wages, electricity, water and telephone bills, bank overdrafts and debts payable.

Assets: owned property e.g.

- Cash at hand.

- Value of farm items e.g. land, store produce, inputs, livestock, growing crops, farm buildings, machinery, equipment etc.
- Debts receivable-for goods and services rendered.
2 types:
 - i) Fixed Assets:- Durable properties held in the farm for a long time e.g. farm buildings, equipment, machinery, perennial crops and land.
 - ii) Current assets: - Held for a short period usually less than one year e.g. Cash at hand and in bank, debts receivable, farm produce to be sold, inputs in store etc

Orders used when drawing a balance sheet

Under assets:-

- i) Order of permanency; -Most permanent assets are written first and the least last.
- ii) Order of liquidity;- Most liquid assets are written first and most permanent last.

Under liabilities: -

- i) Permanent order: - Capital appears first followed by long term liabilities and lastly current liabilities.
- ii) Liquidity order:- Reverse is the case.

A format of a balance sheet

Balance sheet of X as at...Date

Liabilities	Shs. cts	Assets	Shs. cts
Current Liabilities.		Current Assets	
i) Short term debts		i) Cash at hand	
		ii) Cash at bank.	

- ii) Unpaid rent.
- iii) Unpaid wages.
- iv) Bank overdrafts.

Long term

Liabilities.

- i) Bank loan.
- ii) Interest on loan

Total

Liabilities.

Capital/Net worth/Equity

Total

- iii) Debts receivable.
- iv) Stock in store.
- v) Livestock.

Fixed Assets.

- i) Machinery.
- ii) Perennial crops.
- iii) Buildings.
- iv) Land.

Total

- If the value of assets exceeds that of liabilities, the business is **solvent** i.e it can meet all its liabilities and a balance left.
- The balance left is called the net worth/ net capital /owner's equity).
- If the value of liabilities exceeds that of assets, the business is **insolvent**; it cannot meet all what it owes other firms.

Examples

b) Profit and loss account: Is a financial statement showing whether a business made a profit or a loss. It has **2 sides**

- i) Income side;

Details entered;

- Sales and receipts-produce sold and debts receivable
- Closing valuation-Value of assets in the farm by the end of the financial year.

ii) The expenditure side-

Details entered;

- Opening valuation-Are assets in the farm or business by the beginning of a financial year.
- Purchases and expenses: Items bought and debts payable.

A format of a profit and loss account:

**Title-The profit and loss account of-----
for the year.....**

Expenditure	Sh	Cts	Income.	Sh	Ct
	s.	.		s.	s.
Opening valuation			Sales and receipts		
i)			i)		
ii)		
iii)			ii)		
			..		
Purchases and expenses			iii)		
i)		
ii)			Closing valuation.		
iii)			i)		
Total Profit			..		
			ii)		
			..		

iii)
..

Examples:

- If the value of expenditure is more than the value of income, the business has made a loss and if value of income is more than the value of expenditure, the business has made a profit.
- Thus (Closing valuation + sales and receipts) - (opening valuation + Purchases and expenses) = Net profit.

c) Cash Analysis: Is a financial statement drawn up to show the receipts and payment of cash in the business.

Format

Sales and receipts

Purchases and expenses

Date	details	Total dairy maize vegetables poultry date
		details total dairy maize vegetables poultry

Each sale or purchase is entered twice-once in the total column and once in analysis column-a column for specific enterprises that benefit from the sale or purchase of a particular enterprise.

The sum of entries in the total column is equal to the sum of all the entries in all the other columns (analysis column)

Importance:

- Shows money earned and spent on an enterprise.
- Shows total sales and receipts and purchases and expenses.
- Shows the net profit or loss.

AGROFORESTRY

- This is the growing of trees and crops and keeping of animals on the same piece of land.

Forms of Agroforestry

1. Agrosilviculture

- Combination of trees or shrubs and crops in agricultural production.
- It is common in high rainfall areas.

2. Silvopastoral

- Combination of growing trees or shrubs and keeping of livestock.
- It is common in the arid and semi arid areas.

3. Agrosilvopastoral

- Combination of growing trees/shrubs with pastures for livestock and crops.
- Practiced in the high potential areas.

Importance of agroforestry in Kenya

- i). Encourages afforestation/reafforestation
- ii). Source of wood fuel
- iii). Source of income
- iv). Raw material e.g. timber for construction
- v). Act as wind breakers
- vi). Aesthetic value/beauty
- vii). Control soil erosion
- viii). Act as livestock fodder.
- ix). Improves water catchment area
- x). Mark farm boundaries.

Characteristics of Good Agroforestry Trees and Shrubs

- i). **Fast growth** such as eucalyptus, *Grevillea robusta*, *Calliandra calothyrsus*, pines etc.
- ii). **Deep rooted** to ensure minimal competition for mineral nutrients and moisture with the crop plant. Examples include; *Eucalyptus spp*, *Grevillea robusta* etc.
- iii). **Nitrogen fixing** such as; *Calliandra calothyrsus*, *Leucaena spp*, *Cajanus cajan*, *Sesbania sesban* etc.
- iv). **Good in by product production** e.g. timber, fruits and poles. Examples include; *Croton macrostachyus*, *Grevillea robusta*, *Markhamia lutea* etc.

NB:

- i). Trees such as the eucalyptus should not be planted near water sources because they would absorb the water and the source of water may end up drying.*
- ii). Cypress and eucalyptus should not be planted in arable land as their leaves have allelopathic effects on crops i.e. they produce chemicals that inhibit the growth of some crop species.*

Types of Tree Nurseries

1. Direct Nurseries/Bareroot/Swaziland beds

- Seeds are planted directly on the ground without any containers.
- Seedlings here have low survival rate after transplanting due to root injury when uprooting.

2. Containerized nurseries

- Seeds are sown directly in containers such as pots, polythene bags, tins etc which are filled with soil mixtures.

Seed Collection and Preparation

Acquiring Seeds

- Good seeds should be whole, of good size, free from diseases and pests and should be fresh to ensure high viability.
- Seeds should be collected from mature trees, dried, and threshed before use.

Seed Treatment

This is done for two reasons.

- i) To break seed dormancy hence rapid germination.**

Methods of breaking dormancy include

- Hot water treatment e.g. in *Leucaena*, *Calliandra* and *Acacia*.
- Mechanical breaking e.g. in seeds of the croton tree.
- Light burning e.g. in wattle tree seeds.

ii) Seed inoculation to promote nitrogen fixation in leguminous varieties

Nursery Management

The following practices are carried in the nursery while seedlings are growing.

- i) *Mulching.*
- ii) *Watering.*
- iii) *Weed control*
- iv) *Pricking out.*
- v) *Shading.*
- vi) *Pest and disease control.*
- vii) *Root pruning.*
 - This is the pruning of the tap root to encourage the development of a short, dense and strong rooting system.

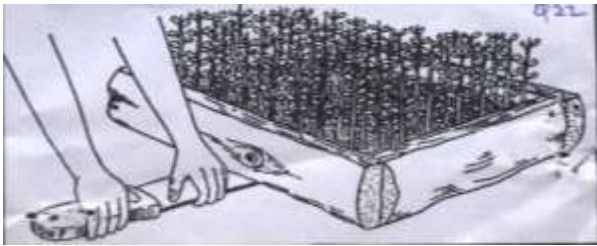

viii) *Hardening off.*

Transplanting

- Holes for planting trees are dug long before transplanting day.
- Topsoil is kept separate and is used for refilling the hole halfway.
- Transplanting should be done at the onset of rains.
- Seedlings should be well watered a day before transplanting. This makes the soil stick onto the roots. It also eases the removal of the polythene sleeves for seedlings raised in sleeves.
- Seedlings are placed at the center of the hole.
- A sharp knife is used to cut and remove the polythene sleeve.

- More soil is added and firmed gently around the plant until the hole is completely full.
- Seedlings should be planted at the same depth as they were in the nursery.
- Watering should be done and mulch provided.
- A temporary shade may be established to conserve moisture.

Care and Management of Trees

i) Protection

- Young seedlings should be protected from damage by animals for about one year.
- This can be done for individual trees or for an entire field.

ii) Pruning and Training

- Pruning is the removal of extra or unwanted parts of a plant.
- Trees may be pruned for use as wood fuel or for fodder.
- Pruning can also be done to train trees to give the required shape or size.

iii) Grafting Old Trees

- When an agroforestry tree is old but has good characteristics, a scion can be taken from another tree that is compatible with it and grafted onto it.
- This is aimed at repairing such a tree.

Agroforestry Practices

i) Alley Cropping.

- This is the growing of trees and crops together. It is also known as hedgerow or intercropping.
- Trees are cut regularly and the leaves are used to mulch the crop.
- The trees used are leguminous so as to fix nitrogen e.g. Leucaena and Calliandra.
- Fruit trees can also be used.

ii) Multi-storey Cropping.

- In this case the trees are spaced widely and left to grow unchecked.
 - Crops which can tolerate shading are planted.
 - The trees and crops form different levels which look like storeys.
 - Tree species for this system include; *Cardia*, *Casuarina equisetifolia* (Whistling pine), *African black wood*, *Muhugu* and *Acacia pp.*
- iii) *Woodlots in Farms.*
- These are plots set aside for trees only.
 - They are usually established on parts of the farm that are not productive.
 - Such trees should be fast growing such as *Acacia* and *Eucalyptus spp.*

Sites for Agroforestry Trees

i) Boundaries.

Such trees help to:

- Protect the farm as fence.
- Mark the boundary.
- Form wind breaks.
- Provide timber and wood fuel.

Such trees include: Eucalyptus, Grevillea, and Jacaranda etc.

ii) River Banks.

- Such trees help to reduce the water velocity along the river banks, protecting exposed soil from erosive forces of the flowing water.

iii) Terraces.

- Roots of trees planted on terraces reduce the speed of water run-off and hold the soil particles together reducing soil erosion.
- Examples of trees here include, *Grevillea*, *Sesbania*, *Calliandra*, avocado, mango, pawpaw etc.

iv) Slopes.

- Trees planted on slopes control soil erosion.
- Eucalyptus, Grevillea, pines and croton trees are planted.

v) Homestead.

- Such trees are planted for beauty, fruits and shade. They should not be planted too close to the house.

Tree Harvesting Methods

i) Pruning

- This is the removal of the branches from the lower part of the tree crown.
- Pruning is done towards the end of the dry season to avoid damage to other crops.
- Branches obtained from pruning are used as fuel or wood fuel.

ii) Lopping

- This is the removal of branches from trees in haphazard manner.
- It is the most common harvesting technique for fodder trees.

iii) Pollarding

- This is the cutting of all the branches and top part of the tree.
- It is usually done to provide fuel wood and fodder.
- It is commonly is trees such as; Croton, Casuarina, Grevillea, Jacaranda, Ficus etc.

iv) Coppicing

- This is the cutting of the whole tree about 30cm above the ground.

- This is done to provide fodder, wood fuel and mulching material.
 - The common coppiced tree species include; *Calliandra*, *Eucalyptus*, *Leucaena* and *Markhamia*.
- v) *Thinning*
- This is the cutting down of some trees to avoid overcrowding.
 - Thinning is done where trees have been established by direct seedling or planted very closely.

FARM POWER AND MACHINERY

FARM POWER---Is the amount of work done per unit time

USES OF FARM POWER

- Operate tools and equipment
- Slashing/ mowing
- Cutting trees
- Tilling of land
- Weeding
- Harvesting of crops

SOURCES OF POWER IN THE FARM

a) Human Power

Advantages

- i)Work in areas impossible for animals and tractor
- ii)Cheap
- iii) Available

Disadvantages

- i)Power is limited to very light tasks.
 - ii) Quality of work produced is low / variable
 - iii)Slow
 - iv)Expensive in the long run.
- V) Health of workers influences the work done.

b) Animal Power

Donkeys, Oxen, Camel

Uses

-Cultivation, Transportation, Planting etc.

Advantages

- i) No skilled workers required.
- ii) Cheaper to buy and maintain.
- iii) Work output is higher than in human beings.
- iv) Can work in areas impossible for tractors/ sloppy areas.
- v) Work better on small holdings than tractors.

Disadvantages

- i) Need a big portion of land for grazing.
- ii) Slower than tractors.
- iii) Cannot work on large land.
- iv) Animals damage crops when used for weeding.
- v) Get sick reducing work output.

Animals are harnessed singly or in pairs using a **Yoke**.

b) Wind Power

Uses

- Dry grains and fodder.
- Winnowing crop yields.
- Pumping water/ drive wind mills.
- Generate electricity.

Disadvantages

- i) Unreliable e.g. direction.
- ii) Strength is unreliable.
- iii) Sometimes not available.
- iv) Not easy to control.
- v) Expensive to purchase a wind mill and its accessories.

d) Water Power

Source_ Running water.

Uses

- Ferrying logs in navigation rivers.
- Produce hydro-electric power.
- Operate different types of machines e.g. Maize grinding mills.

- Driving hydraulic pumps for pumping water for irrigation.

Disadvantages

- i) Some rivers are small and seasonal.
- ii) Expensive to harness the power.
- iii) Some farms are not accessible to moving water.
- iv) Difficult to use since not easy to control.

e) Biomass

Sources

-Biogas, Wood or charcoal.

F) Wood or charcoal

Sources____ Trees in form of fire wood and charcoal

Uses

- Cooking
- Heating
- Dehydrating some crops
- Curing of tobacco

Disadvantages

- E) Exhaustible
- iii) Not used directly in some farm operations
- iv) Large quantities required
- Iv Bulky hence difficult to transport
- v) Pollute the environment

ii) Biogas

Sources

Is a product produced when animal dung is fermented in a **digester** thereby producing a flammable gas – **methane**.

Stages of methane production

Stage I: Animals digest insoluble organic substances by use of microbes to form waste (dung).

Stage II Microbes breakdown soluble substances in dung anaerobically in the digester.

Methane gas is produced.

Uses of Biogas

- Cooking
- Lighting
- Produce electricity
- Heating
- Boiling water
- Internal combustion engines

Biogas plant

Advantages of Biogas

- i) Economical for farmers with zero grazing units.
- ii) The effluent/ slurry provides fertilizer richer in Nitrogen than manure.
- iii) Flies cannot breed.
- iv) Unpleasant odours are removed.
- v) Minimal environmental pollution.
- VI) Reduced deforestation.

Disadvantages of Biogas

- i) Initial capital is high i.e. construction of Biogas digester is expensive.
- ii) Requires high management skills to produce the gas.
- iii) Requires a large number of animals to sustain gas production.
- iv) Only possible where animals are under zero grazing units.
- V) Labour consuming.

(f) Solar Radiation

Source: The Sun

Uses

- Photosynthesis
- Drying of crops prior to storage and processing.
- Provide electric power that is used for Lighting, pumping water, Cooking and heating.
- Distillation of clean drinking water.

(g) Electrical Power

Source

- Geothermal Power
- Hydro_ Power station
- Nuclear Station/ Atomic energy
- Storage battery

Uses

- Run stationary machines e.g. milling, cooking, grinding and water pumps
- Supplies heat and light for operation of brooders
- Cooking
- Operate milking and welding machines
- Run water pumps

Disadvantages

- i) Cannot be used directly in some farm operations e.g. milking, welding etc.
- ii) Lacks in rural areas
- iii) Power failures lead to high losses
- iv) Costly to install and maintain

(h) Fossil Fuel

Naturally occurring sources

- Petroleum oils
- Coal
- Natural gas

Uses

- Petrol and diesel used in burning internal combustion engines
- Kerosene used in lighting rural homes
- Natural gas for cooking and heating in stoves and lighting.

Disadvantages e.g of coal

- i) Expensive to extract
- ii) Low energy value
- iii) Dirty/ a lot of smoke/soot/ pollution

IV) Bulky hence high transport cost

(i) Tractor Power

Source

Tractor engine converts chemical energy (fuel) into mechanical energy that drives farm machinery.

The tractor engine is a four_ stroke cycle i.e. 4 movements of pistons.

Types of Engines

i) The Four_ stroke cycle engine

These cycles are completed in 4 strokes/ 4 movements of pistons.

The crank shaft makes 2 total revolutions.

The 4 cycles include:

- Induction
- Compression
- Power and
- Exhaust

a) Induction stroke/ Intake stroke

Steps

- i) Piston moves down the cylinder
- ii) Inlet valve open
- iii) Exhaust valve is closed
- iv) Fresh fuel and air gets into the cylinder.

b) Compression stroke

Steps

- i) Piston moves up the cylinder
- ii) Inlet and outlet/ exhaust valves are closed
- iii) Fresh fuel mixture is compressed into the combustion chamber.

c) The Power Stroke

Steps

- i) A spark is produced at the spark plug
- ii) The fuel mixture ignites and expands
- iv) The resultant pressure force the piston down the cylinder

d) The exhaust stroke

Steps

- i) Inlet valve closed
- ii) Exhaust valve open
- iii) Piston moves up the cylinder
- iv) Burned fuel mixture is eliminated through the open exhaust valve

Advantages of four stroke Engines

- i) Produce high power and can do heavy farm work.
- ii) Efficient fuel/ oil utilization.
- iii) Perform a wide range of farm operations.
- iv) Efficiently cooled by water thus allowing production of large engine sizes.
- v) Exhaust gases are effectively expelled from the cylinder.

Disadvantages

- i) Expensive to buy and maintain.
- ii) Their use is limited in areas/ sloppy areas
- iii) Require skilled personnel and support services.

Question a) Name the strokes in a four stroke engine and describe how each operates. (12 marks)

b) Describe the functions of a gear box in a tractor. (8 marks)

ii) The two stroke cycle engine

It is found in Mowers, Chain saws, Motor bikes and Water pumps.

The cycles are completed in 2 strokes of the piston.

There are no valves in the engine but three ports; Inlet, Transfer and Exhaust ports located in the cylinder wall.

a) Induction and Compression stroke

Steps

- i) The piston is at the bottom initially.
- ii) Upward movement of the piston opens the inlet port.
- iii) Air/ Fuel mixture is drawn in.
- iv) The piston reaches the top [Top Dead Centre -TDC] and ignition occurs.
- v) Piston is then forced downwards.
- vi) Piston compresses the fuel mixture in the crank case.

b) Power and Exhaust stroke

Steps

- i) Piston is at the top initially
- ii) Ignited gases cause a buildup of pressure in the combustion chamber forcing the piston downwards.
- iii) Piston covers the inlet port and traps fresh fuel mixture in the crank case.
- iv) Further movement of the piston downwards uncovers the exhaust port.
- v) Fuel mixture is transferred from the crank case into the combustion chamber through the open transfer port.

Advantages of 2 stroke cycle Engines

- i) Cheap to buy and easy to maintain.
- ii) Economical in fuel consumption/ consumes less fuel.
- iii) Can be used in a wide range of areas e.g hilly areas.
- iv) Do small works in the farm uneconomical with 4 stroke cycle engines.

Disadvantages

- i) Produce less power hence cannot be used for heavy duties.
- ii) Inefficient in burning fuel to produce power.
- iii) Air cooled hence limited engine sizes.

Structural and Functional differences between Petrol and Diesel Engines

Petrol Engine

Diesel Engine

1. Has a carburetor.	1. Has an injection pump
----------------------	--------------------------

<p>2. Fuel air is mixed in carburetor before it gets into the engine.</p> <p>3. Fuel is ignited by an electric spark.</p> <p>4. Produces little smoke because petrol is completely burned.</p> <p>5. Engine is light in weight and suited for light duties.</p> <p>6. Uses petrol as fuel.</p> <p>7. Uses more fuel per unit distance.</p> <p>8. No extra addition of air or fuel during the induction stroke thus air: fuel ratio is constant. (15:1).</p> <p>9. Has no sediment bowl.</p> <p>10. Operational cost is high because of high fuel consumption.</p>	<p>2. Fuel _air mixed within the cylinder</p> <p>3. Fuel is ignited by compression of air_ fuel mixture in the cylinder.</p> <p>4. Produces a lot of smoke since diesel is not completely burned.</p> <p>5. Diesel Engine is heavy in weight and suited for heavy duties.</p> <p>6. Uses diesel as fuel.</p> <p>7. Uses less fuel per unit distance.</p> <p>8. Air is taken in before induction stroke thus the ratio of Air: fuel is not constant.</p> <p>9. Has a sediment bowl..</p> <p>10. operational cost is low because of low fuel Consumption.</p>
---	---

Systems of the Tractor

a) Fuel System.

2 types

- i) Petrol fuel system
- ii) Diesel fuel system.

i) Petrol Fuel system

Petrol is put in a tank then passed to the carburetor through a pipe fitted with a filter.

It consists of:

- i) **Fuel tank:** Storage of fuel.
- ii) **Carburetor:**

- Atomizes fuel into spray (vapour).
- Introduces fuel air into the Engine.
- Regulates fuel air into suitable proportions/ mix fuel with definite amount of air.

iii) **Fuel pump**: Forces fuel into carburetor.

iv) **Delivery pipe**: connects all devices.

Maintenance

i) Clean the carburetor jets regularly to avoid blockage.

ii) Clean the fuel filter in petrol.

ii) Keep always clean the hole in the fuel tank cap.

ii) Diesel fuel system

Consists of:

i) **Fuel tank**: Storage of fuel.

ii) **Fuel injection (lift) pump**: Force diesel through injection nozzles and breaks into fine spray.

iii) **Fuel filters**: Remove foreign particles from the fuel.

iv) **Delivery pipe**: Connects the various devices.

Maintenance

i) Replace the fuel filters.

ii) Bleeding in case air is entrapped in the system.

iii) Clean regularly the sediment bowl.

b) Electrical system

Consists of:

i) Ignition/Generator/dynamo circuit: Provides electrical current that produces a spark in the Engine.

ii) Starter Motor Circuit: Starts the engine/Rotates the fly wheel which rotates the crank shaft.

iii) Lighting Circuit: supplies electrical current for the lighting system i.e of the head lamp, brake lights etc.

iv) Tractor Battery: stores the electrical energy supplied by the running engine. Also converts the chemical energy into electrical energy.

The electrical energy from the running engine driven by the generator, charges the battery.

Tractor battery contains 6 cells connected together to supply 12 volts.

A battery has 2 sets of plates I.e +ve and – ve terminals.

Care and Maintenance of Tractor Battery

- i) Top with distilled water the level of electrolyte.
- ii) Scrap clean and smear with grease corroded terminals.
- iii) Fix tightly the battery in a box to avoid spillage and damage.
- iv) Fit correctly the battery in a tractor (right place).
- v) Charge the battery regularly and periodically.
- vi) Empty and keep the battery upside down in case of long storage.
- vii) The generator fan belt should be functional to ensure the battery is always charged.

c) Ignition system

Consists of:

- i) ignition coil: Converts or changes the battery voltage from 12v to 6000v required by the spark plugs.
 - Provides a spark at the sparking plugs located in the engine cylinder.
- ii) The Distributer: Distributes the spark or the high voltage current at each spark plug.
- iii) Condenser:
 - Absorbs the self induced current in the primary circuit.
 - Stores the current for a short time.
 - Passes the electric current to the distributor.
- iv) Contact Breaker: Interrupts the normal flow of the current in the primary circuit so as to generate high voltage from the coil.

Common Faults of the ignition system

1. Sudden stopping

Causes

- Poor terminal connections
- Faulty ignition system.

Correction

- Proper tightening of the terminals
 - Proper cleaning and terminal readjustment.
3. Continuous engine running

Causes

- **B**roken leads
- Poor terminal connection.
- Faulty contact breaker

Correction

- Replace the broken leads.
- Clean and tighten regularly the broken leads.

Maintenance of the ignition system

- i) Remove carbon coatings on spark plug electrodes.
- ii) Replace spark plugs with worn out electrodes.
- Iii) Clean contact breaker points.
- iv) Adjust breaker points to lie between 0.30mm to 0.50mm.
- v) Replace the condenser regularly.
- vi) Keep the ignition system dry always.
- vii) Replace ignition wires with poor insulation.

d) The Cooling system

Importance

- Prevents the engine from overheating that causes expansion of engine components which would lead to: Leakage, valve burning, loss of engine power, cracking of the cylinder head and piston seizure in the cylinder.

Types of cooling systems

a) Air

b) Water

I) Air cooled system

-Used in light weight farm machines e.g mowers Motor bikes and Land masters.

Characteristics of air cooled Engines

- Simple in construction.

- Have fins and fan blade which assists in circulation.
- Light in weight since they no radiators or water jackets.

Limitations of Air cooled Engines

- Get hot quickly.
- Use heavy lubricating oils.
- Cooling is not adequate especially when carrying heavy loads.

ii) Water cooled systems

Water absorbs heat from the engine block at a reasonable rate.

Components:

Radiator, Water jackets, Water hoses, Water pump, Thermostat, Funning mechanism etc.

Cooled water is sucked from the bottom part of the radiator with help of water pump.

It is pushed through water jackets and circulates within engine block and cylinder head.

A thermostat: Regulates the temperature of water in the engine at 80 to 90 degrees Celsius.

Hot water is forced back into the radiator for further cooling.

Care and maintenance of water cooling system

- i) Lubricate water pump regularly.
- ii) Use clean water in the radiator.
- iii) Remove trash from the fins.
- iv) Fit all the pipes tightly to avoid leakage.
- v) Fill the radiator with clean water before starting the days work.
- vi) Check regularly and adjust fan belt tension.

e) Lubrication system

Supplies oil to all parts of the engine where friction is likely to occur.

Importance of lubrication system in tractors

- i) Increase efficiency of the machine.
- ii) Reduces tear and wear rate of the machine.

- iii) Reduces the heat created by the rubbing surfaces I.e acts as a seal between them.
- iv) Acts as a cleaning agent ie washes off dust, dirt soot and metal chippings from oil paths to the sump.
- v) Oiling prevents rusting of stationary machines.

Types of lubrication system

- I) Splash feed type
- ii) Force feed type
- iii) Oil mist type.

Types of lubricants

Identified by their viscosity (thickness index) as indicated by (S.A. E)- Society of Automotive Engineers.

The lower the SAE number the thinner the oil.

- i) SAE 10—Thin oil . Gives little protection when heated.
- ii) SAE 50—Thicker oil . Protects bearings.
- iii) SAE 90—150. Transmission oils. Protects clutch, gear box, wheels, ball bearings.

Care and maintenance of lubrication system

- i) Do not use old and contaminated oil as a lubricant.
- ii) Drain oil while still hot to avoid sticking on sump walls.
- iii) Replace oil filters.
- iv) Use the correct oil type as per manufacturer's instructions.

f) Power transmission system.

Transfers power from tractor Engine to drive shaft, wheel axle P.T.O shaft and Hydraulic system.

Consists of:

1) The Clutch:

Functions

- i) Connects or disconnects the drive shaft to or from the engine.
- ii) Enables the tractor to take off gradually and smoothly.
- iii) Provides power from the engine to P.T.O shaft.

The clutch uses friction force to transmit power from the engine.

It has three parts: Crank shaft, friction disc and pressure plate.

2) **Gear box**

Functions

- Provides different forward speeds.
- Enables the driver to choose any forward or reverse gear to suit the operation.
- Allow change in speed ratio by altering the gears.
- Allows the driver to stop the tractor without suddenly stopping the engine or the foot keeping pressed on clutch.

3) **The differential.**

Functions

- Change the direction of drive to right angles so that power is transmitted to the rear wheels.
- Enables the rear wheels to travel faster or slower than others especially when negotiating corners.
- Differential lock avoids wheel slip or skidding.

4) **Final Drive.**

-Enables the wheels to propel the tractor machine either forward or backward.

Tires allow maximum grip (traction) i.e. where the wheels provide large surface area of contact between the tires and the ground.

Power transmission mechanism

Ways power is transmitted from the engine

i) Propeller Shaft

-Connects the gear box to the differential that has axle s which drives the wheels. During forward movement, the tractor pulls or pushes attached implements.

ii) The power Take off Shaft (P.T.O) Shaft

-Located at the rear part of the tractor and rotates at the same speed as the crank shaft. It

-is connected to the mowers, planters, rotavators, shellers, sprayers and fertilizer spreaders.

iii) Hydraulic system

-Operated by a lever near the driver's seat .Attached to the 3 point linkage which lowers or raises attached implements e.g. mowers, planters, ploughs, and sprayers.

iv) Draw bar

-Is at the rear part of the tractor. Does not get power directly from the engine. Attaches trailed implements used for harrowing, transportation and rolling.

Tractor Servicing

Are practices or operations carried out to keep the tractor in good and efficient working condition thereby increasing its lifespan.

REVISION QUESTIONS

1. a) i) What is agricultural economics?

- The art and science of organizing limited resources to achieve maximum returns

ii) Explain the meaning of scarcity and choice

- Productive resources are scarce in relation to demand i.e goods and services produced are not enough to satisfy human wants
- Therefore, a choice has to be made on which goods and services should be produced using the limited resources.

b) Explain how the house hold and firm are both producers and consumers.

- The household demands goods and services and supplies labour and raw materials to firms
- Firms convert the raw materials and supplies finished goods to households.
- The relationship generates money to both sides therefore both are producers and consumers.

c) What do the following terms mean?

- i) Gross domestic product (G.D.P)

- The sum total of goods and services produced by a country within one year.

ii) Gross national income (GNI)

- Total output from resources owned by the nationals of a country both within and outside the country within a year.

iii) Per capita income

- Gross national income divided by total population

d) i) What does the term opportunity cost in farming mean?

- Cost of the foregone alternative when we make a choice.
- Example is choosing to grow maize instead of wheat.
- Opportunity cost is the value of wheat
- Opportunity cost only exists where there are alternatives.

ii) State the main implications of opportunity cost in farming.

- Poor decision leads to losses
- Correct decision leads to good profits

iii) When is opportunity cost nil or zero?

- When supply is unlimited
- When goods are free
- When there are no alternatives

2. a) i) What is production?

- The process of transforming productive resources e.g land, labour and capital into consumption resources e.g potatoes, maize and milk over a period of time.

ii) State the factors of production.

- Land (provides space for production)
- Labour (human effort)
- Capital (man made to assist other factors)
- Management (organises other factors)

b) i) Name the sources of capital for farming.

- Credit facilities

- Personal savings and earnings
- Inherited property.
- Free grants

ii) How is labour classified?

- Family
- Hired (casual/permanent)

iii) State the functions of farm manager

- Planning i.e. short and long term
- Gathering information
- Comparing levels of production with those of neighbouring farms
- Detecting weaknesses and constraints and finding ways and means of overcoming them
- Keeping up to date farm records
- Implementing farm management decisions
- Taking responsibilities

c) i) State the law of diminishing returns

- In a production process, if variable additional units of an input are increased while all other factors are held constant, there will be an increase in additional output until a point is reached when the additional output per additional units of input declines.

ii) State agricultural examples of this law.

- Use of varying units of labour on a fixed unit of land
- Feeding dairy cattle with varying units of feed for milk production
- Using varying units of fertilizer in the production of a given crop

d) i) What is production function?

- The relationship between the units of input that a farmer employs in production and the corresponding units of output
- The output depends on inputs hence output is a function inputs.

ii) Name the types of production function?

- Increasing returns
- Constant returns
- Decreasing returns

iii) What is a decreasing returns production function?

- A production function where each additional unit of input results into a smaller increase in output than the proceeding unit of input.

3. Give 4 qualities desirable in a farm manager.

4. State 4 ways of improving labour in the farm.

5. State 4 management guideline questions which assist manager in decision making.

6. State 4 characteristics of variable inputs.

7. Give two examples of each of the following;

- **Variable inputs.**
- **Fixed inputs.**