

NAME: _____ SIGNATURE _____

456/1
MATHEMATICS
PAPER 1
NOVEMBER, 2024
 $2\frac{1}{4}$ hours



CLEVERLAND HIGH SCHOOL-MAYA
END OF YEAR ASSESSMENT EXAMS 2024
Senior Two
MATHEMATICS
PAPER 1
2 hours and 15 minutes

INSTRUCTIONS TO STUDENTS;

- Attempt two questions in section A and At least 2 questions from section B with at least one question from each part.

SECTION A

Attempt all the questions in this section

Item 1

Mr. Kato's family has siblings, Shamim, Gorret, David, Juma and Esther. There is an interval of 2 years between the ages of children from Esther to Shamim. Shamim is 2 years old.

Mr. Kato and Wasswa have chapatti making chapatti to St. Lawrence schools and St. Joseph of Nazareth respectively to support their families. They take chapattis to those schools at intervals of 30 minutes and 40 minutes respectively. They first took chapattis together at 8:30. However they are uneducated.

Task.

- As a mathematician help them to know the time when they will take chapattis to those schools again at the same time.
- Using an arrow diagram, explain the information about Mr. Kato's family.

Item 2

You are the CEO of a certain construction company that has been contracted to construct a bridge in a swamp has a scale reading 1:250,000. On this map, the swamp of the area is 7.36cm^2 .

According to the work plan, you will use either a bulldozer vehicle if the actual area of the swamp is less than 40km^2 or an excavator vehicle if the actual area of the swamp is greater than 40km^2 . If you are to use a bulldozer, 25 operators will be needed each being paid UGX 65,000 per day and if you are to use an excavator, 14 operators will be needed each being paid UGX 125,000 per day. The company has been given fifty million shillings to do the work in only two weeks.

Task.

- (a) (i) Calculate the actual area of the swamp in km^2 .
- (ii) Which types of vehicle are you going to use?
- (b) How much money will be paid to the operators for the duration you will construct the bridge?
- (c) What is the difference between your payment and director's payment?

SECTION B

PART I

Attempt one question from this part

Item 3

Your guardian has a budget of shs.700, 000 for your school expenses. To get to the school where your guardian wishes to take you for 'A' Level, your guardian drove 4km east from your home to the stage and then 8km north to reach there. However, you realized later that there was a direct route from home to school your guardian could have used.

On reaching the school, you found out that, the school fees, admission fees and uniform fees are shs. 900,000, shs. 100,000 and shs. 350,000 respectively. The school also offers a bursary of: 60% off school fees free admission and eighty seven thousand five hundred shillings off uniform fees to those who got first grade according to you results, you qualify for this bursary.

It also has two payment plans on school fees that the guardians can choose from and they are;

- Paying in two installments that is to say, two thirds of the school fees at the beginning of the term and the balance at their visitation day or end of term.
- Paying in three equal installments, at the beginning of the term, on visitation day and end of term respectively.

Task.

- (a) How far is it from your home to school if you travel through the direct route?
- (b) (i) Since you qualify for the bursary, how much will you pay?
(ii) Will your guardian afford the school expenses according to his budget?
- (c) (i) How much will those who are to pay school fees of shs. 900,000 pay per installment, according to each of the payment plans?
(ii) Which payments plan would you recommend for them and why?

Item 4

The ministry of health in Uganda is conducting a survey about the existence of Malaria in three districts: A, B and C. The ministry will then come up with control measures if the chance of a person testing positive having visited at least one of the districts is above 50%. The ministry has intentionally selected a sample of people who visited the three districts and tested them for malaria. The results have revealed that 50 people who visited district A, 60 people who visited district B and 40 people who visited district C tested positive for malaria. Additionally, 20 people who visited both districts A and B, 10 people visited district A and C and 15 people visited districts B and C tested positive for malaria. The ministry has also discovered that 20 people who only visited district C tested positive for malaria and 40 people who visited the three districts tested negative for malaria.

Task.

- (a) Determine the number of people that were tested for malaria by the ministry of health.
- (b) Calculate the probability of a person testing positive having visited at least one of the three districts.
- (c) Advise the ministry of health, with a reason based on calculations whether to come up with control measures or not.

PART I

Attempt one question from this part

Item 5

Lukowe a piggery farmer in Sakabusolo village constructed a rectangular sty on her land the length of the sty is 5m more than the width and it's area = 104m^2 .

Task.

Help Lukowe to determine the perimeter of her sty.

Item 6

Gift a student at Cleveland High School-Maya uses a bucket for bathing every morning as she is going to school and in the evening after classes and uses this water in the ratio of 2:3 in the morning and evening respectively for a bucket collected from the borehole at full capacity.

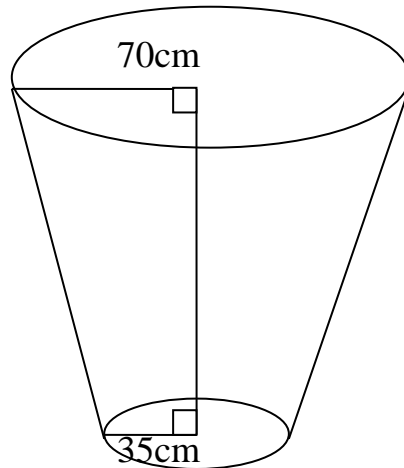

Task.

- (a) Help gift to calculate the amount of water she usually fetches from the borehole for bathing.
- (b) How much water does she use for bathing in the morning?

END

MERRY X-MASS AND HAPPY NEW YEAR