

535/2



Physics Practical

Paper 2

July/Aug 2024

2 Hours

**MEBU EXAMINATIONS CONSULT**  
**UGANDA CERTIFICATE OF EDUCATION**  
**PHYSICS PRACTICAL**  
**PHYSICS CONFIDENTIAL**

Great care should be taken that the information given below does not reach the candidates either directly or indirectly.

The description of the apparatus specified below does not necessarily correspond with the description in the question paper

Candidates are not allowed to use reference books

Each candidate should be provided with the following;

**ITEM 1**

1 Helical Spring with a pointer attached

1 Retort stand with a clamp

1 Meter rule

6 slotted masses, each of 100g

**ITEM 2**

1 Constantan wire labeled X of SWG 28 and length 80 cm

1 Constantan wire labeled Y of SWG 30 and length 80 cm

1 Ammeter (0 – 1.0A)

1 Voltmeter (0 – 3.0V)

1 Meter rule

2 crocodile clips

4 pieces of connecting wires, each of length 50 cm

1 Switch

1 Double cell holder

2 torch dry cells of Emf 1.5V each of size D

**END**

545/2

Chemistry Practical inst.

Paper 2

July/Aug 2024

2 Hours



**MEBU EXAMINATIONS CONSULT**  
**UGANDA CERTIFICATE OF EDUCATION**  
**CHEMISTRY PRACTICAL**

**Paper 2**

**2Hours**

**CONFIDENTIAL INFORMATION**

Great care should be taken that the information given below does not reach the candidates either directly or indirectly.

The description of the reagents and chemicals specified below does not necessarily correspond with the description in the question paper

Candidates are not allowed to use reference books

Each candidate should be provided with the following;

1 burette (50cm<sup>3</sup>)

1 pipette (25.0cm<sup>3</sup> or 20.0cm<sup>3</sup>) 1 measuring cylinder (10cm<sup>3</sup>)

1 measuring cylinder (100cm<sup>3</sup>)

1 conical flask (250cm<sup>3</sup>)

1 plastic beaker (250cm<sup>3</sup>)

1 thermometer

200cm<sup>3</sup> of distilled water

200cm<sup>3</sup> of BA1

50cm<sup>3</sup> of BA2

## Easy access to

Heat source

Distilled water

**NB:**

**BA1** is prepared by dissolving **80g** of sodium hydroxide to make a litre of solution

**BA2** is prepared by dissolving **54.4cm<sup>3</sup>** of concentrated Hydrochloric acid to make a litre of solution.

The teacher responsible for preparing the chemicals should hand in his/her trial results properly sealed in a separate envelope and firmly fastened to the candidates' scripts envelope.

Teachers who do not submit their trial results will be responsible for the performance of their learners.

**END**

553/2 Inst. sch.

BIOLOGY

PRACTICAL INSTRUCTIONS

AUGUST 2024.

2 Hours



## **MEBU EXAMINATIONS CONSULT**

**UGANDA CERTIFICATE OF EDUCATION**

### **MOCK ASSESSMENTS 2024**

#### **BIOLOGY PRACTICAL INSTRUCTIONS**

553/2 Inst.sch.

#### **CONFIDENTIAL.**

This information is given only to facilitate preparation of the examination.

Great care should be taken that the information given below does not reach to the candidates either directly or indirectly.

#### **INSTRUCTIONS FOR PREPARING SPECIMENS AND APPRATUS:**

The teacher responsible for preparing specimens must ensure that candidates are provided with correct specimens and other materials as specified

In these instructions. Specimens and solutions which have been assigned codes should be presented to candidates using those codes only and not any other identity.

**Each candidate should be provided with;**

1. 100cm<sup>3</sup> of the Irish Potato Extract labeled K.
2. 100cm<sup>3</sup> of 10% sucrose solution labeled L
3. 10 vol. H<sub>2</sub>O<sub>2</sub> labeled M.
4. Thoracic vertebra labeled N1
5. Lumbar vertebra labeled N2
6. Cervical vertebra labeled N3

7. Access to:
8. Reagents for food tests.
9. Beakers
10. Hand lens
11. Source of heat.
- 12.8 Test tubes
- 13.2 Boiling tubes

**END**

527/2

AGRICULTURE

Confidential.

August, 2024

2 HOURS



**MEBU EXAMINATIONS CONSULT**

**UGANDA CERTIFICATE OF EDUCATION**

**PRINCIPLES & PRACTICES OF AGRICULTURE.**

**CONFIDENTIAL**

This information is only given to facilitate preparation of examination.

Great care should be taken that the information given below does not reach the candidates either directly or indirectly.

**INSTRUCTIONS FOR PREPARING SPECIMENS AND APPARATUS:**

The teacher responsible for preparing specimens must ensure that candidates are provided with correct specimens and other materials as specified in these instructions. Specimens and solutions which have been assigned codes should be presented to candidates using those codes only and not any other identity.

A candidate is to be provided with each of the specimens. Where a specimen is to be used by more than one candidate, the teacher preparing specimens must devise a suitable system to enable the candidates to take turns at each specimen.

**F** - Alkaline loam

**G** - Acidic loam.

**O** - Pure milk sample

**P**- Milk Sample mixed with distilled water

**Q** - Milk Sample adulterated with flour.

**2** petri dishes.

Blue and red litmus papers.

Distilled water.

**2** spatulas.

Beaker.

Universal Indicator.

Barium Sulphate.

**2** 1000cm<sup>3</sup> measuring cylinders

Lactometer.

Thermometer.

**END**

NAME:..... INDEX NO: 

--	--	--	--	--	--	--	--

SCHOOL:.....

SIGNATURE:.....

553/1

BIOLOGY PAPER 1

(THEORY)

MOCK 2024

AUGUST

TIME:2 HRS:30 MIN



# MEBU EXAMINATIONS CONSULT

## Uganda Certificate Of Education

MOCK ASSESSMENTS 2024

BIOLOGY PAPER 1

(THEORY)

TIME:2HRS:30MINS

### INSTRUCTIONS TO CANDIDATES

This paper consists of **Seven** examination items. It has **two** sections; **A** and **B**.

Section **A** has **three** compulsory items.

Section **B** has two parts; **1** and **11**. Answer **One** item from each part.

Any additional item(s) answered will **NOT** be scored



**SECTION A**

**Attempt all items in this section in the space provided**

Downloaded from www.mtutoonline.com, More PASTPAPERS are available

**ITEM 1**

In a local garden, the plants have recently been showing signs of damage. The leaves have holes, the stems are chewed, and some plants are even uprooted. Upon a closer inspection, you noticed several types of animals around the garden.



**TASK.**

- (a) Describe the types of damage insects, Herbivores and burrowing animals can cause to plant leaves.

.....

.....

.....

.....

- (b) Explain how this damage affects the plant's ability to perform photosynthesis.

.....

.....

.....

.....

.....

.....

.....

- (c) Explain how continuous damage by these animals could impact the overall health and growth of the plants in the garden and suggest some methods to protect the plants from animal damage.

**ITEM 2**

Alex, an athlete, has been experiencing various health issues and decides to visit their doctor for a thorough check-up. They have been training intensively for a major competition, but they are facing several challenges. Alex has noticed fluctuating energy levels, difficulty in maintaining their blood sugar, unusual tiredness, and weight gain despite a healthy diet and regular exercise. Additionally, Alex's partner, Taylor, is planning to start a family, and they both want to understand how their bodies are functioning hormonally.

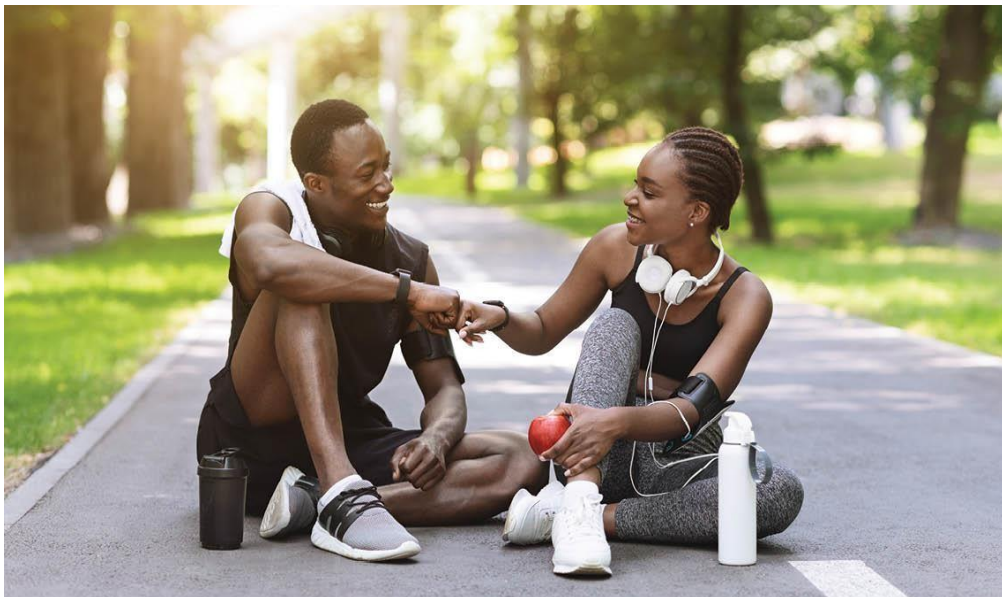

**TASK**

(a) Alex wants to boost muscle growth and performance naturally. Which organ in their body is primarily responsible for producing the hormone that plays a key role in muscle growth and what is this hormone called?

.....

.....

.....

(b) Alex's doctor suspects an issue with their body's ability to regulate glucose. Which organ

should the doctor focus on and what hormone is involved in this process?

Downloaded from www.muutoonline.com, More PASTPAPERS are available

(c) Alex has experienced increased thirst and frequent urination. Which organ should be investigated for producing the hormone that regulates water balance and blood pressure and what is this hormone called?

**ITEM 3**

Emily is a 15-year-old high school student who recently started experiencing irregular menstrual cycles. Her mother, Sarah, has a genetic disease which affects blood clotting. Emily is concerned about her menstrual health and whether she might have inherited her mother's condition.



**TASK**

(a) Explain the normal process of the menstrual cycle, including the key phases and their functions

.....

.....

.....

.....

.....

.....

(b) What could be some common reasons for irregular menstrual cycles in teenagers?

(c) Describe what the genetic disease is and how it affects the body.

(d) How is hemophilia inherited, and what are the chances that Emily might have inherited this condition from her mother? Discuss how the genetic disease could potentially affect Emily's menstrual cycle and what symptoms she should look out for.

## SECTION B

This section has **two** parts, each with **two** items. Choose **two** items from this section, picking **one** item from each part

### PART 1

#### ITEM 4

Imagine you are a biologist on an expedition deep within the Amazon Rainforest, one of the most bio-diverse places on Earth. Your mission is to study the diversity of living organisms in a specific area of the forest. As you set up your research station, you begin to observe and document various forms of life around you. One of your team members argues that conserving the biodiversity of the rainforest is crucial and during your exploration, you come across an area that has been deforested.

#### TASK

What are some reasons you might provide to support the importance of biodiversity in this ecosystem and what are some potential impacts of deforestation on the biodiversity of Amazon Rainforest? How might this affect the organisms you are studying?

#### ITEM 5

You are a climate scientist advising a coastal city that is facing increasing risks due to global warming. The city is experiencing rising sea levels, more frequent and severe storms, and higher temperatures. Local officials are concerned about how these changes will impact the city's infrastructure, economy, and residents.

#### TASK

How would you assess the specific risks that global warming poses to the city's infrastructure, such as its transportation systems, buildings, and utilities? What factors would you consider in your assessment? What long-term planning measures would you suggest to ensure the city remains resilient to future climate changes? How would you integrate climate data and projections into the city's development plan?

### PART II

#### ITEM 6.

You are a wildlife biologist studying animals in the Arctic, where extreme cold and seasonal

changes present unique challenges. You're particularly interested in how different species have adapted their body structures and physiological processes to survive in this harsh environment.

**TASK.**

You observe that Arctic foxes have different fur densities compared to other canids. How does this adaptation help them survive the extreme cold? What role does their fur play in thermoregulation? Polar bears are known for their large size and energy demands. How do their respiratory and circulatory systems adapt to ensure they get sufficient oxygen and nutrients in the cold, low-oxygen environment of the Arctic?

**ITEM 7.**

You are a nephrologist working in a hospital where a patient has been admitted with symptoms of severe dehydration and electrolyte imbalance. The patient's medical history reveals that they have been experiencing frequent urination and abnormal lab results showing elevated levels of urea and creatinine in their blood.

**TASK**

Describe the key steps in the excretion process in the human body, including how the kidneys filter blood, produce urine, what treatment options would you consider addressing the patient's dehydration and electrolyte imbalance. How might these treatments support or restore normal kidney function? Based on the patient's condition, what preventive measures or lifestyle changes would you recommend avoiding future issues with kidney function and maintaining overall health?

**END**

NAME:..... INDEX NO: 

--	--	--	--	--	--	--	--

SCHOOL:.....

SIGNATURE:.....

845/1  
ENTREPRENEURSHIP EDUCATION  
PAPER 1  
MOCK 2024  
AUGUST  
TIME:2 HRS:30 MIN



# MEBU EXAMINATIONS CONSULT

## Uganda Certificate Of Education

MOCK ASSESSMENTS 2024

ENTREPRENEURSHIP EDUCATION

PAPER 1

TIME:2HRS:30MINS

### INSTRUCTIONS TO CANDIDATES

- This paper consists of **two** sections **A** and **B**.
- Attempt **ALL** items in section **A**.
- Attempt only **one** item from section **B**.
- Attempt four (**4**) items in all.

Downloaded from www.mutisonline.com More PASTPAPERS are available

### ITEM ONE.

In Lugazi town council, Buikwe district, most of the youths are unemployed and spend their time betting. They have advised to form a saving scheme to start any agribusiness because of the many benefits but they are worried of the challenges people face in operating agribusiness.

#### TASK

- a) As a student of entrepreneurship, help them to identify any five types of agribusinesses. **(05 scores)**
- b) Explain the benefits of agribusinesses. **(10 scores)**
- c) Outline the challenges encountered in operation of the business. **(10 scores)**

### ITEM TWO

The government of Uganda is planning to construct a Standard Gauge Railway (SGR) line between Kampala and Kenya which will promote regional trade between the two countries (East Africa). This project shall require large amounts of money to get it finished on time.

#### TASK

- a) Advise the government on the possible sources of funds for the project. **(10 scores)**
- b) How will the government of Uganda benefit after the completion of the project? **(10 scores)**
- c) What challenges are traders likely to face while carrying out regional trade? **(05 scores)**

### ITEM THREE

Keynes bakery started in 1990 and produces different products in the business. During this period, the business was alone in Mubende district. Currently, many bakeries have come up and are competing with Keynes bakery. The customers are running away from Keynes products and one of the reasons given is poor customer care and the employee labour turnover is high.

#### TASK

- a) How can employees of Keynes bakery practice good customer care to customers? **(10 scores)**
- b) Advise Keynes bakery on how to attract and retain the customers to buy its products. **(10 scores)**
- c) Explain the benefits of practising business ethics to the entrepreneurs. **(05 scores)**



## SECTION B

### ITEM 4

You have been given the following information from RICKWO traders for the year ended 31<sup>st</sup>

December 2021

ITEMS	Shs.
Purchases	3,600,000
Sales	5,000,000
Stock (01.01.2021)	600,000
Return outwards	700,000
Carriage on sales	600,000
Return inwards	800,000
General expenses	300,000
Debtors	900,000
Insurance	120,000
Cash at bank	760,000
Creditors	600,000
Machinery	1,200,000
Stock (31 <sup>st</sup> December, 2021)	980,000
Furniture and fittings	480,000
Advertising	100,000
Salaries and wages	1,000,000
Drawings	400,000
Cash in hand	240,000
<b>Capital</b>	<b>sh.4, 800,000</b>

## TASK

- a) From the relevant information, prepare the financial statement that can determine the profit and loss made by the business. **(20 scores)**
- b) Define the financial position of the business. **(05 scores)**

## ITEM FIVE

The following information relates to Mr. Kigoye, a business man in Mpigi for the month Jan, 2020.

1<sup>st</sup> Jan, 2020 Kigoye started business with shs800, 000 as his capital.

3 <sup>rd</sup> bought a machine for cash	shs280, 000
4 <sup>th</sup> sold goods for cash	shs300, 000
8 <sup>th</sup> bought goods for cash	shs350, 000
12 <sup>th</sup> paid insurance in cash	shs180, 000
20 <sup>th</sup> paid electricity in cash	shs240, 000
22 <sup>nd</sup> sold more goods for cash	shs350, 000
25 <sup>th</sup> cash drawings	shs120, 000
30 <sup>th</sup> paid wages in cash	shs130, 000

## TASK

- a) As a student of financial management, help Mr. Kigoye to record the transactions in the relevant ledger accounts and balance them at 31<sup>st</sup> Jan 2020. **(20 scores)**
- b) Prepare a statement that will help him to check the arithmetic accuracy of the ledger balance. **(05 scores)**

**END**

NAME:..... INDEX NO: 

--	--	--	--	--	--

SCHOOL:.....

SIGNATURE:.....

223/1



CHRISTIAN RELIGIOUS  
EDUCATION  
MOCK EXAMS  
AUGUST 2024  
2 HOURS

# MEBU EXAMINATIONS CONSULT

## Uganda Certificate Of Education

MOCK ASSESSMENTS 2024

CHRISTIAN RELIGIOUS EDUCATION

**TIME:2HRS:30 MINS**

### INSTRUCTIONS TO CANDIDATES:

- This examination consists of **six** items. It has **two** sections **A** and **B**.
- Respond to **FOUR** items in all.
- Section **A** has two compulsory items.
- Section **B** has **two** parts **I** and **II**. Respond to **One** item from each part.
- Any additional item(s) responded to will **not** be scored.
- All responses must be written in the booklet(s) provided

Downloaded from [www.mtline.com](http://www.mtline.com), More PASTPAPERS are available

## SECTION A

Respond to all items in this section

### ITEM 1

Downloaded from www.tutonline.com, More PAST PAPERS are available  
Lord” I have so many enemies. So many people have turned against me. They say to themselves, God will not rescue him. But you, Lord, protect me. You bring me honor, you give me hope. I will pray to the Lord, and He will answer me from his Holy Mountain. I can lie down to rest and know that I will wake up, because the Lord covers and protects me. So, I will not be afraid of my enemies even if thousands of them surround me. Psalms 3:1-6 **GNB**

- ask
- a). How can the above text help modern Christians to strengthen their faith in God? **(10 Scores)**
- b). Relate the above Biblical text with African traditional ways of understanding God. **(10 Score)**

### ITEM 2

Nakandi and Nabaweesi are married to Ssekitoleko for a period of ten years. Ssekitoleko gave each of them land to carry out farm work and other related family activities. However Nakandi is not contented with the land her husband gave her. She is always conflicting or fighting with her co-wife claiming that Nabaweesi land is more fertile than hers. This has intensified their sour relationship.

### TASK

- a) By using Christian approaches, advise Nakandi and Nabaweesi on how to settle their differences in their family. **(10 scores)**
- b). Using African traditional approach, show how the two should settle the conflict and live in peace. **(10 scores)**

## SECTION B

### PART 1 (Choose One Item from This Part)

#### ITEM 3.

The Lord hates people, who use dishonest scales, he is happy with honest weight. People who are proud will soon be disgraced. It's wise to be modest.

If you are good, you are guided by honesty. People who can't be trusted are destroyed by their own dishonesty. Riches will do you no good on the day you face death, but honesty can save you. Honesty makes a good person's life easier but to the wicked, will cause their downfall. Righteousness rescues those who are honest, but those who can't be trusted are trapped by their own greed. When the wicked die, their hope dies with them, Confidence placed in riches comes to nothing. Proverbs 11:1-7 GNB

#### TASK

- a). Using the Christian view, how can the above text help Christians to acquire and live with their wealth. (10 scores)
- b). Relate the above text with how modern people acquire wealth. (10 scores)

#### ITEM 4.

Mukasa has two boys who completed their studies. However they are not willing to work with their father who is a farmer, they go for destructive leisure activities like clubbing, alcohol, drug abuse, discos and most times are arrested by police and it's their father to bail them out. They have failed completely to develop themselves.

#### TASK

Use the traditional and Christian approaches and advise Mukasa on how to deal with the situation in the scenario. (20 scores)

## PART 11

(Choose one item from this part)

### ITEM 5.

But I tell you, love your enemies and pray for those who persecute you, that you may be children of your father in heaven. He causes sun to rise on evil and the good and sends rain on the righteous and the wicked. If you love those who love you, what reward will you get? Are not even the tax collectors doing that? And if you greet only your people, what are you doing to others? Do even pagans do that? Be perfect, therefore as your heavenly father is perfect.

Mathew 5:44-48 NIV.

### TASK

i). Using Christian knowledge how can the above text help Christians to live in harmony with their neighbors. **(10 Scores)**

ii). Relate the above text with the African traditional ways of maintaining peace and harmony.

### ITEM 6.

In Wakimese village, there existed a wrangle between Mr. Ssekabira and his neighbor Mr. Kairu. The battle came as a result of land boundary which they share. Mr. Ssekabira accused Mr. Kairu of being aggressive as he uses the boundary by force. As a result, they fought and almost killed each other. The chairperson called for a village meeting to reconcile them. All the village members agreed that the two should reconcile and forgive each other. However, the two have failed to reconcile and their misunderstanding is intense.

### Task

Using the modern and Christian approaches, explain how people should resolve the conflict.

**(20 Scores)**

**END**

NAME:..... INDEX NO: 

--	--	--	--	--	--	--	--

SCHOOL:.....

SIGNATURE:.....

12/1

ENGLISH LANGUAGE

MOCK 2024

AUGUST

TIME:2 HRS



# MEBU EXAMINATIONS CONSULT

## Uganda Certificate Of Education

### MOCK ASSESSMENTS 2024

#### ENGLISH LANGUAGE

TIME:2HRS

#### INSTRUCTIONS TO CANDIDATES.

This paper consists of two sections: A and B. It has four examination items.

Section A is compulsory.

Answer one item from section B.

Answer three examination items in all

Answers to section A must be written in the spaces provided

Answer to section B must be written in the answer booklets provided.

Any additional items answered will not be scored.

#### FOR EXAMINERS USE ONLY

FOR EXAMINERS USE ONLY		
Section	Score	Examiner's Signature
A		
B		
Total		

## SECTION A

Item 1.

Read the text below.

Sleep is an important component for the proper functioning of the brain. According to brain scientists and researchers, seven hours is not sufficient time for sleep. The right amount of sleep is close to ten hours.

Adequate sleep is important for the following reasons;

Sleep is not a mere luxury but an absolute must in preparing one's body and brain for productive life.

The process of sleep, if given adequate time and properly provided, it energizes the body and brain.

Sleep facilitates growth because the secretion of a growth hormone reaches its peak in sleep. A growth hormone is a chemical secreted by the pituitary gland. It stimulates growth of specific neural connectors for physically held memories in the brain to take place.

Adequate sleep facilitates memory storage, retention, organization, as well as new learning and performance of the brain.

The mood of a person and one's threshold for containing anger is facilitated by adequate sleep. If an individual gets enough sleep, he or she will be able to relax under his pressure, have immunity to disease and viral infection.

In Uganda today, it is usual to find children doing homework until 9pm, going to bed around 11:00pm and waking up as early as 5:00am to prepare for school.

Adequate sleep plays an important role. It assists in having a high concentration span; especially short term memory handling complex tasks, thinking logically, assimilating and analyzing new information.

It is therefore important that children and adults have adequate sleep for a good health.

Parents should establish a regular sleep, wake up schedule seven days in a week.

Choose a reasonable bed time that will allow adequate sleep of nine to ten hours.





Downloaded from [www.nutsonline.com](http://www.nutsonline.com), More: PASTPAPERS are available

**FAIR COPY**

Downloaded from [www.mutoonline.com](http://www.mutoonline.com), More PASTPAPERS are available

**ITEM 2. Read the text below**

The dichotomy between fate and free will has been a perennial conundrum in philosophical discourse. On one hand, the concept of fate suggests that the course of events in our lives is predetermined and immutable, thereby negating the notion of personal agency. Conversely, the idea of free will posits that individuals possess the autonomy to make choices that shape their destinies. However, the interplay between these two seemingly disparate concepts is far more complex than a simple binary opposition.

Consider the existentialist perspective, which posits that human existence is characterized by an inherent meaninglessness, and that individuals must create their own purpose in life. This philosophy appears to champion the notion of free will, yet simultaneously acknowledges the presence of external factors that can influence human decision-making. Furthermore, the concept of determinism, which asserts that every event is the inevitable result of prior causes, seems to undermine the idea of free will altogether.

**QUESTIONS**

- a) What is the central debate discussed in the passage? (2 Scores)

.....

.....

.....

.....

.....

.....

.....

.....

.....

.....

.....

b) How does the concept of existentialism relate to the idea of free will? (03 Scores)

Downloaded from www.mutoonline.com, More PASTPAPERS are available

.....

.....

.....

.....

.....

.....

.....

.....

What is the significance of the term "dichotomy" in the context of the passage? (02 Scores)

.....

.....

.....

.....

.....

c) Analyze the relationship between fate and personal agency as presented in the passage. (04 Scores)

.....

.....

.....

.....

.....

.....

e) How does the concept of determinism challenge the notion of free will? (03 Scores)

.....

.....

.....

.....

.....  
.....  
What is the author's stance on the debate between fate and free will? (02 Scores)

SECTION B

EITHER:

ITEM 3.

Your club had an outing and members misbehaved while there. This did not only affect students but also tarnished the school's reputation. As a club chairperson, draft a write up to address the misconduct. (Use 250-300 Words)

OR:

ITEM 4.

You were falsely accused of assaulting an old woman, you were arrested and taken to the police station. Write your talk to the police officer who interrogated you at the police station. (Use 250-300 Words).

END

NAME:..... INDEX NO: 

--	--	--	--	--	--	--	--

SCHOOL:.....

SIGNATURE:.....

273/1

GEOGRAPHY PAPER 1

MOCK 2024

AUGUST

TIME:2 HRS:45 MIN



# MEBU EXAMINATIONS CONSULT

## Uganda Certificate Of Education

MOCK ASSESSMENTS 2024

GEOGRAPHY PAPER 1

TIME:2HRS:45 MINS

### INSTRUCTIONS TO CANDIDATES

- This paper consists of **TWO** sections; **A** and **B**. It has **SIX** examination items.
- Section **A** has **TWO** compulsory items.
- Section **B** has **TWO** parts; **I** and **II**. Answer **ONE** item from each part
- Answer **FOUR** examination items in **ALL**
- You may use diagrams where applicable to illustrate your answers
- Any additional item(s) answered will **NOT** be scored
- **ALL** answers **MUST** be written in the answer booklet provided

## SECTION A: Maps and photograph skills

Answer ALL Items in this Section

### ITEM 1: Map Skills

For this item, use the East Africa 1:50,000 (Uganda) map extract of Buliisa series Y732, sheet 9/4, Edition 3- USD, the information in the text below and the support materials provided to answer the tasks given.

BDK Construction Company has signed a contract to construct a road from Kimoli (GR.285426) to Anaka (GR.285485). The company is supposed to send a group of surveyors to locate the place, however they got lost from Buliisa road junction.

### Support Material



shutterstock.com · 476503663

### Task

- Using the knowledge of bearings and direction, write to the surveyors directing them to Kimoli from where they are lost. (04 scores)
- Identify with the aid of a relief section diagram the physical challenges the company is likely to face during construction. (12 Scores.)
- Assuming the company is to construct the road at a rate of 2 billions per kilometer, determine the total cost of the Road. (04 Scores)



## ITEM 2: Photograph Skills

Study Fig. 2, a photograph taken from one of the places from south western Uganda and text provided below it.



**Fig.2**

You are working as the chairperson of Uganda Investment Authority (UIA). A group of investors from Europe have visited Uganda and are planning to have a meeting with the Uganda Investment Authority (UIA). One of the investment target area is the one shown in the photograph. As the chairperson of UIA, you are required to make an enticing speech to motivate them invest in this area.

### Task

- Draw a landscape sketch of the photograph and on it mark and name any two relief features , three vegetation types and two land uses that can be of interest to the visitors. (09 scores)
- Identify and explain to the investors the investment possible ideas in the area. (05 scores)
- With evidence from the photograph explain the challenges investors are likely to face in the area. (06 scores)

## SECTION B

This section has two parts, 1 and II.

### PART 1

Answer ONE item from this part.

#### ITEM 3

John's mother, who has been working with Kampala Capital City Authority for over 10 years, has been terminated from work and decided to relocate to her land she bought in Rubanda. The land is located near Lake Bunyonyi. The whole family is scared of the next life style.

#### Support Material:



ask.

a) As a geography student, explain to the family of John how Lake Bunyonyi was formed.

(05 scores)

b) Write an essay of about 300 words advising John's family on how they can earn a living in their new home area.

(15 scores)

#### ITEM 4

East African countries for over the years have been trying to boost trade between themselves and other countries. They have therefore come up with different initiatives to increase production and earnings from trade. However, despite all the efforts, earnings from exports have remained low due subsistence production dominating most of the East African countries. This has worried

business communities and experts who have organized an economic meeting to find out the solution to the regional economic challenges.

### Support Material



ask

As the Minister of trade from Uganda, write a speech to be read in the meeting citing challenges associated with unfavorable balance of trade and how the region can boost its export trade.

(20 scores)

### Part II

Answer one item from this part

#### ITEM 5.

Sudan experiences little or no rain fall of less than 50mm annually in the North, between 200-700mm in the Central. This has resulted into difficulty in promoting modern agriculture especially in the rural areas like Kosti, El-Ducim, HasaHeisa, Gezira, Managil among others. Despite all the efforts by the Sudanese government to promote its agricultural sector, it has encountered a number of challenges.

Downloaded from www.mutoonline.com, More PAST PAPERS are available

## Support Material

### A bar line graph showing the climate of Gezira in Sudan

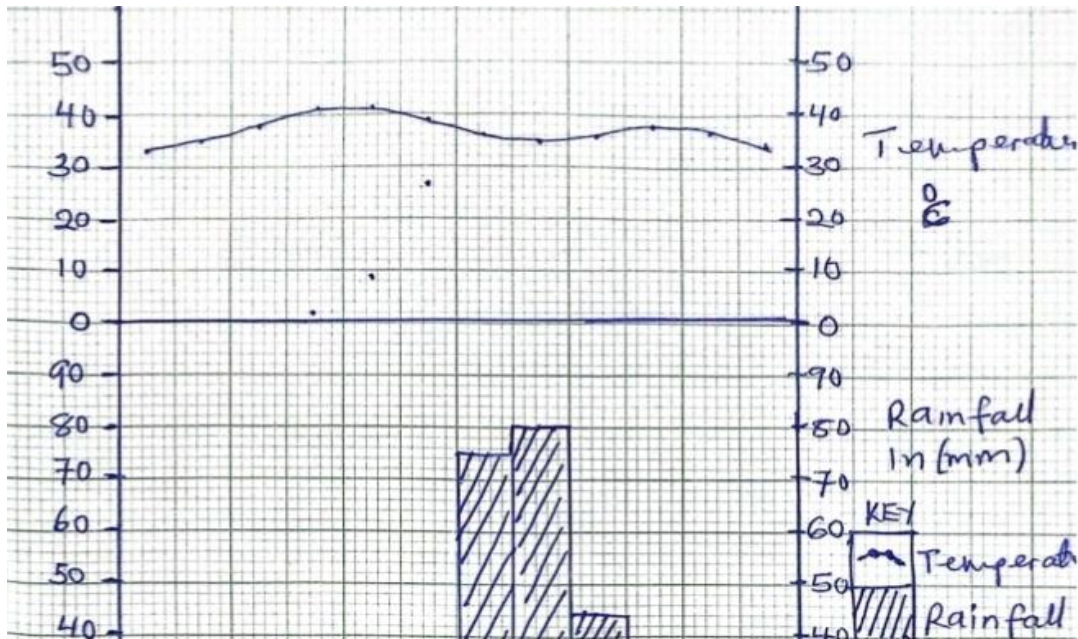

ask

a). Basing on the text and the support material provided, describe the climate of Sudan.

(05 scores)

b). Write an essay specifying the challenges of agricultural modernization in Sudan and the way forward.

(15 scores)

## ITEM 6.

In 2020, The Uganda's tourism industry was hit by outbreak of Covid-19. This led to abrupt fall in the Tourism earnings in the country. Studies show that by 2015, Tourism contributed 67500 US dollars, 2016 it contributed 72200 US dollars, In 2017 the earnings were 80600 US dollars. 88500 US dollars were earned in 2018. In 2019, about 142000 US dollars were earned, but in 2020, the earnings reduced to 38000 US dollars. This situation resulted into widespread unemployment and poverty in many societies of the region.

## Support Material.



**ASK.**

2. As a Statistician, you have been requested to use a Bar or Line graph method to show the above information for clear analysis by the public. (10 scores)
3. Using the information provided in the text, write an article between **250-300** words to be published in the newspaper that will help the tourism industry regain its glory. (10 scores)

**END**

NAME:..... INDEX NO: 

--	--	--	--	--	--	--	--

SCHOOL:.....

SIGNATURE:.....

585/1  
PHYSICS PAPER 1  
(THEORY)  
MOCK 2024  
AUGUST  
TIME:2HRS:30 MIN



# MEBU EXAMINATIONS CONSULT

## Uganda Certificate Of Education

MOCK ASSESSMENTS 2024

PHYSICS PAPER 1

(THEORY)

TIME:2HRS:30 MIN

### INSTRUCTIONS TO CANDIDATES:

This paper consists of **two** sections; **A** and **B** It has **Seven** examination items.

Section **A** has **three** compulsory items.

Section **B** has **two** parts; **I** and **II**. Answer **one** item from **each** part.

Answer **five** items in all.

Any additional item(s) answered will not be scored.

All answers **must** be written in the answer sheets provided.

## SECTION A

### ITEM 1

A war erupted in a certain mountainous area surrounded by a small water body where soldiers only communicated by throwing a stone in water to alert their colleagues of danger ahead. Instead, this alerted their enemies. One of the soldiers had small pieces of plane mirrors and a torn paper box in his bag. Their leader sent spies to pop behind the hills to see if the enemies were hiding there, but many were captured and killed. They totally lacked knowledge on how to solve this problem. The enemy troops had a radio call that they used for communication and wave forms of wave length were produced on the receiver's computer clearly indicating the amplitude, period and time taken for the wave to reach the receiver at the headquarter. One afternoon, it threatened to rain and bright colors of different kinds spread in the sky. This scared the soldiers even more.

### HINT

A graph obtained from the receiver's computer

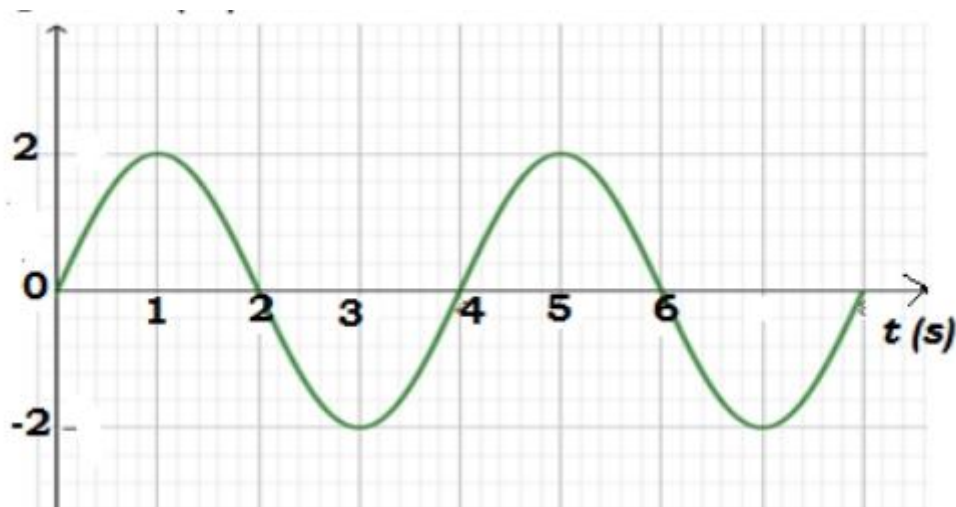

TASK;

As a physics learner, help the soldier to:

- Understand why the throwing of the stone in water always alerted their enemies.
- Know the best way they could reduce the rate at which their spies were being killed and captured.
- Understand the strange appearance of the sky that sent them to hideouts.
- Determine the frequency at which the waves reached the receiver at the home base of the army.

### ITEM 2

A certain town experienced an atomic bomb blast, many people were killed in the incidence and others survived with serious injuries. The government advised those who survived to relocate to other places of the country because this village was not safe for them at that time. The scientists carried out a scientific investigation using detectors of radiations and found out that the environment was still radioactive as shown below.

Time(days)	0	22	42	62	82	102	122	142	162
Count rate (min-1)	106	83	66	56	47	36	31	26	15

The scientists recommended that the environment would be safe for use again when they obtained half-life value which was less than 60 days and they will need like one year (356 days) for the environment to be free from radioactive wastes and materials.

### TASK:

As a learner of Physics, use your knowledge to;

- Help the people know the half-life value and advise them accordingly.
- Sensitize the people about the risk associated with radioactive materials and how they should be handled.
- Help the people understand the value of neutrons of the nuclide Y formed when a radioactive substance of mass number 208 and atomic number 104 decays by emitting 3 alpha particles, 4 beta particles and gamma rays to form a nuclide Y.

### ITEM 3

During a news bulletin broad cast live at night from America, viewers watch from Uganda during day time on TV. The reporters show live images of an eclipse happening, which is something the viewers had never seen.

Task.

Use your knowledge of Physics to help the viewer's understand;

- Why it is day time where they are and night time on a live broad cast on TV?
- What an eclipse is?
- How it's possible for a live broadcast to happen in one country and be watched in another country?

## SECTION B

### Part I

Answer **ONE** item from this part

#### Item 4

Students in a certain school are going for a trip in a mountainous area where the maximum height one is allowed to climb is 1km per day. They were allowed to have stop overs at specific points for various reasons. They had also been warned of the possibility of nose bleeding while climbing the mountain. Another group of students who had visited the same place earlier told



them their first stop over was at a place B where a barometer reads 68.2cmHg, while it read 75.7cmHg at a place A which was going to be their starting point. The students were told that the cooking would be done at place A but they couldn't understand why that was so. Use your knowledge of physics to help the students:

- (a) Determine if they will be allowed to climb beyond point B.
- (b) Identify when they were more likely to nosebleed.
- (c) To explain why the cooking had to be done at Point A.

### Item 5

Eunice is required to bathe her younger brother James as instructed by her mother. According to the advise from the family doctor, the bath should be between 40°C and 42°C. Eunice has two litres of hot water at 100°C and 6litres of water at 20°C. Eunice has to do mixing in an Aluminium saucepan of mass 3.5kg and specific heat capacity 650JKg<sup>-1</sup>K<sup>-1</sup>

Task;

As a learner of physics,

- (a). Help Eunice establish whether water is warm enough for James to bathe after mixing.
- (b). In what ways would you prevent the water from cooling very fast?

## PART II

Answer **one** item from this part

### ITEM 6.

A home owner was recently told electricity from a power substation is transmitted at 12 KV using thick aluminium cables to be used in a house at 240V. The home owner is however confused by how the electricity changes voltage from one value to another and says the thick cables are a waste of money. Inside the house are two sets of appliances of resistance 20Ω and 30Ω but the house owner is not sure of how they should be connected to ensure they work effectively. Use your knowledge of physics to;

- (a) Help the home owner understand how the electricity changes from 12 KV to 240V.
- (b) Why thick aluminium cables are used?
- (c) How the appliances should be connected to ensure that they work effectively with a high amount of current.

### ITEM 7

The welders in a certain workshop are troubled with their tools being shocked by electricity from a generator of 240V. When they visited a technician, they were advised to wind a copper wire to 3000 turns around a soft iron ring on the receiving part so as to output 120V suitable for their

work shop operations fixed in a box. However, the welders seem bothered of how this will be of help.

### Task

As a learner of physics,

- (a) Explain to the welders how the above design will produce power corresponding to their consumption.
- (b) Help the welders to determine the number of turns to be wound on the output part of the device.
- (c) Comment on how efficient the device if the ratio of current output to current input is **1.5**.
- (d) Advise the welders on how to improve the efficiency of the device.

**END**

NAME:..... INDEX NO: 

--	--	--	--	--	--	--	--

SCHOOL:.....

SIGNATURE:.....

505/2  
PHYSICS PAPER 2  
(PRACTICAL)  
MOCK 2024  
AUGUST  
TIME:2 HRS



# MEBU EXAMINATIONS CONSULT

## Uganda Certificate Of Education

MOCK ASSESSMENTS 2024

PHYSICS PAPER 2

(PRACTICAL)

TIME:2HRS

### INSTRUCTIONS TO CANDIDATES

This paper consists of **Two** examination items.

Answer **One** item in **All**.

Any additional item answered will **NOT** be scored.

Candidates are **Not Allowed** to start working with the apparatus for the **First Quarter Of An Hour**. This time is to enable candidates to read the items thoroughly, checking for the apparatus they will need and plan appropriately.

A graph paper will be provided.

Mathematical tables and silent non-programmable calculators may be used.

## ITEM 1.

"Green Thumb Tools" is a gardening equipment company that plans to produce retractable hose reels. The reels require a spring mechanism that can reliably extend and retract the hose. The head engineer has suggested that the spring used must obey Hooke's law to ensure consistent performance. The company has sent a sample of the spring they plan to use for testing.

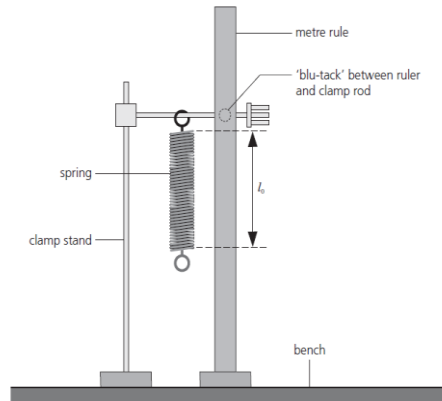

### Task:

- You have been provided with a sample spring that the company intends to use in the retractable hose reel. Conduct an investigation to determine if the spring obeys Hooke's law. Provide a detailed report on your findings and recommendations based on the experimental data.
- Based on your experiment, what can you conclude about the spring constant and the behavior of the spring under different loads?

## ITEM 2.

Conductivity is the measure of how well a material allows the flow of electric current. When selecting materials for electrical wiring, it is preferred to use materials with high conductivity to reduce energy loss and improve efficiency. This is important in many applications, including the wiring of electrical circuits in homes and electronic devices.

Imagine you are tasked with designing the electrical system for a new apartment complex. There are two types of wire materials available **X** and **Y**. Both types have different conductivity properties.

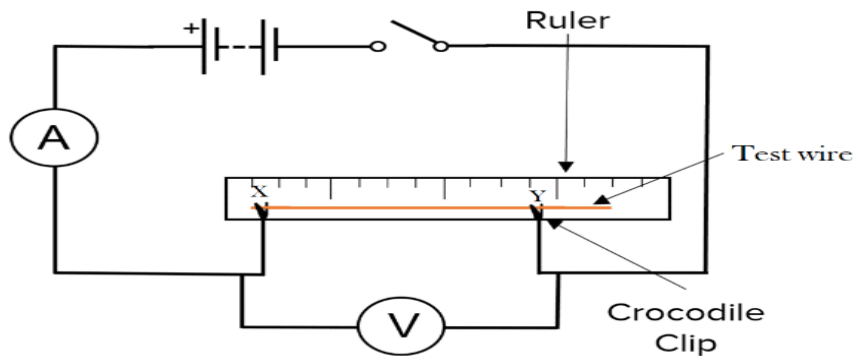

### Task:

- You are provided with the two wire samples **X** and **Y**, both having the same length and cross-sectional area. Conduct an experiment to measure the resistance of each wire. Provide a detailed report on which wire should be used in the apartment complex to ensure efficient energy usage and justify your choice based on the experimental data.
- What can you say about the relationship between the material of a wire and its conductivity based on your experiment?

**END**

NAME:..... INDEX NO: 

--	--	--	--	--	--	--	--

SCHOOL:.....

SIGNATURE:.....

545/2  
CHEMISTRY PAPER 2  
(PRACTICAL)  
MOCK 2024  
AUGUST  
TIME:2 HRS



# MEBU EXAMINATIONS CONSULT

## Uganda Certificate Of Education

### MOCK ASSESSMENTS 2024

#### CHEMISTRY PAPER 2

#### (PRACTICAL)

TIME:2HRS

#### INSTRUCTIONS TO CANDIDATES

- This paper consists of **ONE** compulsory examination item.
- Answers **MUST** be written in the spaces provided. Use **blue** or **black** ink to write.
- **ALL** answers **MUST** be written in the spaces provided with clear working.
- Graph paper is provided for you in the paper.
- You are **not** allowed to use reference books like text books, and practical booklets.
- You are advised to **carefully** read the item, make sure you have all the apparatus and chemicals you may need and then plan appropriately before starting.

<b>FOR ASSESSMENT USE ONLY</b>		
<b>ITEM</b>	<b>SCORES</b>	<b>EXAMINERS' INITIAL ONLY</b>
<b>1</b>		
<b>TOTAL</b>		



b). Carry out the experiment and record your findings.

Downloaded from [www.mtobonline.com](http://www.mtobonline.com), More PASTPAPERS are available

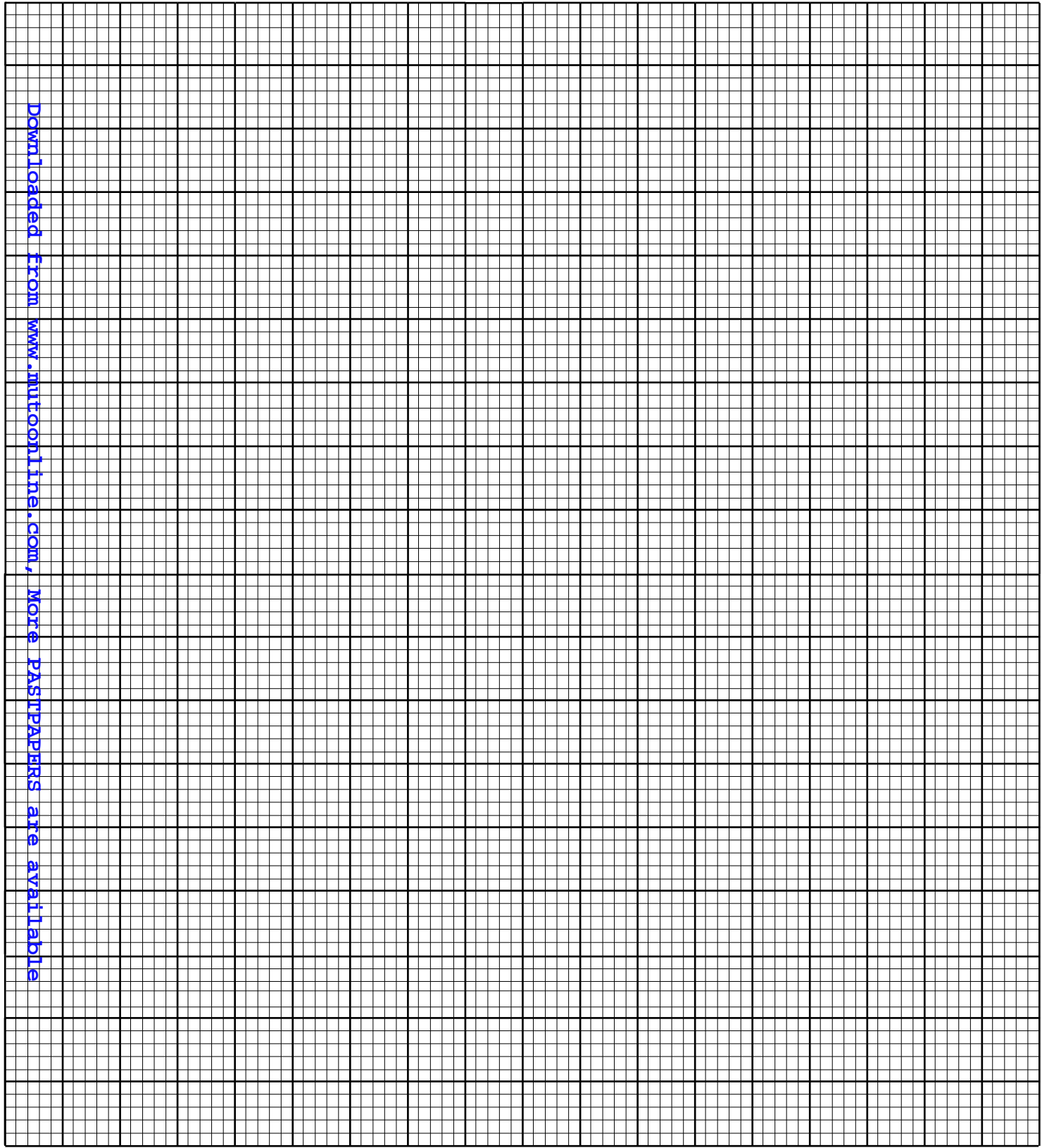

c). what can John and his classmates deduce from your findings

.....

.....

.....

**END**



NAME:..... INDEX NO: 

--	--	--	--	--	--

SCHOOL:.....

SIGNATURE:.....

456/1

MATHEMATICS  
PAPER 1  
MOCK EXAMS  
AUGUST 2024  
1 ¼ HOURS



# MEBU EXAMINATIONS CONSULT

## Uganda Certificate Of Education

MOCK ASSESSMENTS 2024

**MATHEMATICS**

**PAPER 1**

**TIME:2HRS:15 MINS**

### INSTRUCTIONS TO CANDIDATES:

This paper consists of **two** sections; **A** and **B**. It has **six** examination items.

Section **A** has **two** compulsory items.

Section **B** has **two** parts; **I** and **II**. Answer **one** item from each part.

Answer **four** examination items in all.

Any additional item(s) answered will **not** be scored.

**All** answers **must** be written in the Answer booklet(s) provided.

Graph Paper is provided.

Silent, non-programmable scientific calculators and mathematical tables with a list of formulae may be used.

## SECTION A

Answer **All** Items in this section.

Downloaded From [www.mt.com](http://www.mt.com) Line 1, 2, 3, 4, 5, 6, 7, 8, 9, 10, 11, 12, 13, 14, 15, 16, 17, 18, 19, 20, 21, 22, 23, 24, 25, 26, 27, 28, 29, 30, 31, 32, 33, 34, 35, 36, 37, 38, 39, 40, 41, 42, 43, 44, 45, 46, 47, 48, 49, 50, 51, 52, 53, 54, 55, 56, 57, 58, 59, 60, 61, 62, 63, 64, 65, 66, 67, 68, 69, 70, 71, 72, 73, 74, 75, 76, 77, 78, 79, 80, 81, 82, 83, 84, 85, 86, 87, 88, 89, 90, 91, 92, 93, 94, 95, 96, 97, 98, 99, 100, 101, 102, 103, 104, 105, 106, 107, 108, 109, 110, 111, 112, 113, 114, 115, 116, 117, 118, 119, 120, 121, 122, 123, 124, 125, 126, 127, 128, 129, 130, 131, 132, 133, 134, 135, 136, 137, 138, 139, 140, 141, 142, 143, 144, 145, 146, 147, 148, 149, 150, 151, 152, 153, 154, 155, 156, 157, 158, 159, 160, 161, 162, 163, 164, 165, 166, 167, 168, 169, 170, 171, 172, 173, 174, 175, 176, 177, 178, 179, 180, 181, 182, 183, 184, 185, 186, 187, 188, 189, 190, 191, 192, 193, 194, 195, 196, 197, 198, 199, 200, 201, 202, 203, 204, 205, 206, 207, 208, 209, 210, 211, 212, 213, 214, 215, 216, 217, 218, 219, 220, 221, 222, 223, 224, 225, 226, 227, 228, 229, 230, 231, 232, 233, 234, 235, 236, 237, 238, 239, 240, 241, 242, 243, 244, 245, 246, 247, 248, 249, 250, 251, 252, 253, 254, 255, 256, 257, 258, 259, 260, 261, 262, 263, 264, 265, 266, 267, 268, 269, 270, 271, 272, 273, 274, 275, 276, 277, 278, 279, 280, 281, 282, 283, 284, 285, 286, 287, 288, 289, 290, 291, 292, 293, 294, 295, 296, 297, 298, 299, 300, 301, 302, 303, 304, 305, 306, 307, 308, 309, 310, 311, 312, 313, 314, 315, 316, 317, 318, 319, 320, 321, 322, 323, 324, 325, 326, 327, 328, 329, 330, 331, 332, 333, 334, 335, 336, 337, 338, 339, 340, 341, 342, 343, 344, 345, 346, 347, 348, 349, 350, 351, 352, 353, 354, 355, 356, 357, 358, 359, 360, 361, 362, 363, 364, 365, 366, 367, 368, 369, 370, 371, 372, 373, 374, 375, 376, 377, 378, 379, 380, 381, 382, 383, 384, 385, 386, 387, 388, 389, 390, 391, 392, 393, 394, 395, 396, 397, 398, 399, 400, 401, 402, 403, 404, 405, 406, 407, 408, 409, 410, 411, 412, 413, 414, 415, 416, 417, 418, 419, 420, 421, 422, 423, 424, 425, 426, 427, 428, 429, 430, 431, 432, 433, 434, 435, 436, 437, 438, 439, 440, 441, 442, 443, 444, 445, 446, 447, 448, 449, 450, 451, 452, 453, 454, 455, 456, 457, 458, 459, 460, 461, 462, 463, 464, 465, 466, 467, 468, 469, 470, 471, 472, 473, 474, 475, 476, 477, 478, 479, 480, 481, 482, 483, 484, 485, 486, 487, 488, 489, 490, 491, 492, 493, 494, 495, 496, 497, 498, 499, 500, 501, 502, 503, 504, 505, 506, 507, 508, 509, 510, 511, 512, 513, 514, 515, 516, 517, 518, 519, 520, 521, 522, 523, 524, 525, 526, 527, 528, 529, 530, 531, 532, 533, 534, 535, 536, 537, 538, 539, 540, 541, 542, 543, 544, 545, 546, 547, 548, 549, 550, 551, 552, 553, 554, 555, 556, 557, 558, 559, 560, 561, 562, 563, 564, 565, 566, 567, 568, 569, 570, 571, 572, 573, 574, 575, 576, 577, 578, 579, 580, 581, 582, 583, 584, 585, 586, 587, 588, 589, 590, 591, 592, 593, 594, 595, 596, 597, 598, 599, 600, 601, 602, 603, 604, 605, 606, 607, 608, 609, 610, 611, 612, 613, 614, 615, 616, 617, 618, 619, 620, 621, 622, 623, 624, 625, 626, 627, 628, 629, 630, 631, 632, 633, 634, 635, 636, 637, 638, 639, 640, 641, 642, 643, 644, 645, 646, 647, 648, 649, 650, 651, 652, 653, 654, 655, 656, 657, 658, 659, 660, 661, 662, 663, 664, 665, 666, 667, 668, 669, 670, 671, 672, 673, 674, 675, 676, 677, 678, 679, 680, 681, 682, 683, 684, 685, 686, 687, 688, 689, 690, 691, 692, 693, 694, 695, 696, 697, 698, 699, 700, 701, 702, 703, 704, 705, 706, 707, 708, 709, 710, 711, 712, 713, 714, 715, 716, 717, 718, 719, 720, 721, 722, 723, 724, 725, 726, 727, 728, 729, 730, 731, 732, 733, 734, 735, 736, 737, 738, 739, 740, 741, 742, 743, 744, 745, 746, 747, 748, 749, 750, 751, 752, 753, 754, 755, 756, 757, 758, 759, 760, 761, 762, 763, 764, 765, 766, 767, 768, 769, 770, 771, 772, 773, 774, 775, 776, 777, 778, 779, 780, 781, 782, 783, 784, 785, 786, 787, 788, 789, 790, 791, 792, 793, 794, 795, 796, 797, 798, 799, 800, 801, 802, 803, 804, 805, 806, 807, 808, 809, 810, 811, 812, 813, 814, 815, 816, 817, 818, 819, 820, 821, 822, 823, 824, 825, 826, 827, 828, 829, 830, 831, 832, 833, 834, 835, 836, 837, 838, 839, 840, 841, 842, 843, 844, 845, 846, 847, 848, 849, 850, 851, 852, 853, 854, 855, 856, 857, 858, 859, 860, 861, 862, 863, 864, 865, 866, 867, 868, 869, 870, 871, 872, 873, 874, 875, 876, 877, 878, 879, 880, 881, 882, 883, 884, 885, 886, 887, 888, 889, 890, 891, 892, 893, 894, 895, 896, 897, 898, 899, 900, 901, 902, 903, 904, 905, 906, 907, 908, 909, 910, 911, 912, 913, 914, 915, 916, 917, 918, 919, 920, 921, 922, 923, 924, 925, 926, 927, 928, 929, 930, 931, 932, 933, 934, 935, 936, 937, 938, 939, 940, 941, 942, 943, 944, 945, 946, 947, 948, 949, 950, 951, 952, 953, 954, 955, 956, 957, 958, 959, 960, 961, 962, 963, 964, 965, 966, 967, 968, 969, 970, 971, 972, 973, 974, 975, 976, 977, 978, 979, 980, 981, 982, 983, 984, 985, 986, 987, 988, 989, 990, 991, 992, 993, 994, 995, 996, 997, 998, 999, 1000

### ITEM ONE.

A secondary school consists of 24 lower secondary school prefects. The prefects plan to hold a meeting this Saturday in one of the school main halls. The school hall can accommodate many people as it has single seats arranged in 8 rows and 12 columns. The school has bought 48 bottles of mineral water, 120 bottles of soda and 84 cups of juice. 17 prefects drink soda, 12.5% of the prefects do not drink soda or juice and 9 prefects drink juice. Each bottle of the drinks costs Shs. 1,000/=.

### TASK:

- Using an appropriate chart, display the categories of drinks bought.
- Work out how much money was used to buy bottles of drinks for people who drink both soda and juice if they will drink two bottles each.

### ITEM TWO.

You are on a management committee that is organising a farewell party for 2024 candidates in your school. The committee wants to establish the number of people to attend the party keeping the cost as minimum as possible. You have been assigned a department of drinks which has a maximum amount of shs. 450,000. You are planning to buy crates of soda and Jerrycans of juice. Each crate of soda costs shs. 20,000, a Jerrycan of juice is shs. 30,000. You intend to buy more crates of soda than Jerrycans of juice. The Jerrycans of juice should be more than 6 and the crates of soda should be less than 12. Each person will be served only one type of drink once and in the budget, 24 students are to take a crate of soda and 20 students are to take a full Jerry can of juice.



Source: [www.alarmy.com](http://www.alarmy.com)

## TASK:

- (a) Write down mathematical statements to show the relation between the number of crates of soda and the number of Jerrycans of juice.
- (b) Show the feasible regions of the relation on the Cartesian plane.
- (c) With reasons basing on calculations, help the committee to establish the number of students who are to attend the party at a minimum cost.

## SECTION B

*This Section has **two** Parts; **I** and **II**.*

### Part I

*Answer **ONE** item from this Part.*

## ITEM THREE.

Three schools from a Kinyaanya region wanted to participate in the National Schools Football Sports Gala that was to be held in Kitwalo district playground. Unfortunately, none of the schools had a school bus and they wanted to hire a bus for one day of the gala. The bus charged sh. 25,000 per km moved. The three schools through their Sports master agreed to share the cost of the bus equally amongst themselves. On that day, they set off at 4:30 AM and increased the speed gradually to 90 Km/hr reaching Mpangira at 6:45 AM. From there, the bus driver maintained the same speed for  $2\frac{1}{4}$  hours reaching Kikwate. From Kikwate, he reduced slowly in speed reaching Kitwalo at 9:30 AM. The games started at 10:00 AM and each team played six games and the results were as follows;

School **A** won **3** games, drew **2** and lost **1** game,

School **B** won **4** games and lost **2** games,

School **C** won **2** games and drew **4** games.

The organizers awarded **three** points for a win, **one** point for a draw and **No** point for a loss. They declared these schools the winner, 1<sup>st</sup> runner up, and 2<sup>nd</sup> runner up in the order of the points they obtained from the games and it was to be used as a way of distributing the money to the three schools. The total prize money was sh. 16,500,000.

**Task:**

- a) Find how much each school paid for the bus.  
b) Help the organisers decide on how to properly distribute the cash prize for each school.

**ITEM FOUR.**

A school DOS is thinking of how he can boost the mathematics department of your school. He can either add another teacher or buy more books or both. He has decided that he will do both if the average performance for this year for the 40 students is lower than that of the previous which was 77.

He asked the department to give a test and these were the students' marks.

70	71	40	48	61	70	30	62
64	63	60	51	55	25	32	65
64	45	65	50	45	40	25	45
58	45	30	38	30	28	24	48
60	48	28	35	50	48	50	60

He also visited the library and found out that the previous candidates used three books for their revision. A, B or C. From the librarian's records, it is clear that all the candidates that did not use any of books failed the subject greatly. Out of the 35 candidates of this year, 13 used A, 20 used B and 17 used C. 9 used A and C, 3 used A and B while 8 used B and C only. The records show that students used all the three books. He observed that he should replace one book type of the three with D since no student read it only alone.

**TASK:**

- (a) (i) Help the DOS group the marks to make an informed decision on the fate of the department and defend it.  
(ii) Display the students' marks in groups on a simple statistics diagram.
- (b) (i) Help the head teacher identify the book he should replace and explain why?

(ii) Find the probability that a student selected randomly from the class failed.

## Part II

Answer **One** Item From This Part.

### ITEM FIVE.

Kakubi and Kasamba are new employees in a motor company. The company offers each of them a total monthly pay of shs. 1.5 million. The monthly total payments for Kakubi include the benefits totaling to shs.300, 000 while that of Kasamba include the benefits like; Housing shs. 100,000, daily transport shs.4000, break and Lunch shs.120, 000 and family shs.150, 000. At the end of the month, they received less and different amounts of money in their accounts and they went to the finance office which is always busy. They were given a tax revenue document that they failed to understand and they came to you for help with the document below

able income (Shs)	evied (%)
100,000	
100,000	
200,000	
300,000	
inder of the money	

Kasamba decided to buy a motorcycle priced shs.7,000,000 from the same company. The company has two payment options. Cash payments which usually offer a deduction of 5% of the marked price or paying 10% of the price followed by monthly payments of shs 500,000 each month for 14 months.

### TASK:

- Basing on the financial document, justify that the two employees received different amounts in their accounts and who received more.
- Which mode of purchasing the motorcycle favours Kasamba and why?

**ITEM SIX.**

Mr. Mugagga is buying a container to start a hardware in Kigagga Village to sell bags of cement. Each bag occupies an area of 0.8 cubic meters. The container is  $ABCDEFGH$  with  $AB = 12\text{m}$ ,  $BC = 9$ ,  $ADEF$  is a square and  $O$  is the point of intersection of  $AC$  and  $BD$ .

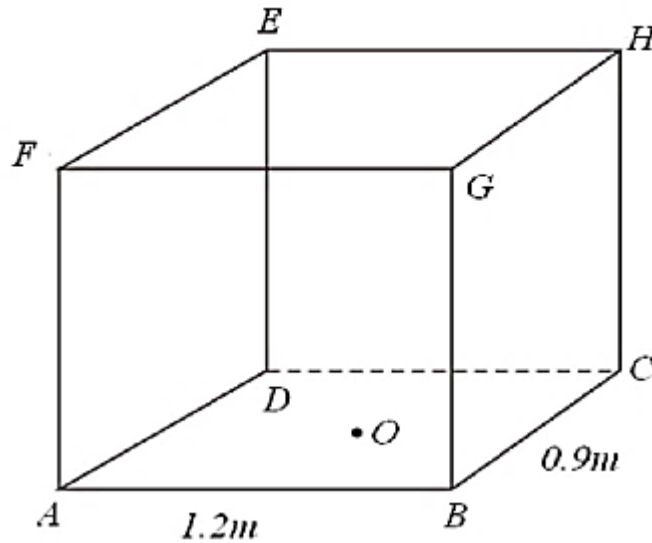

ask:

- (a) Assist Mr. Mugagga to determine the distances below for a better shape construction to suite his need;
- (i) BE
  - (ii) OH
- (b) (i) Determine the angle Mugagga will have to use in order to put a support between BE and the base.
- (ii) In case Mugagga is to cover the BDH and the base, what angle does he have to use?
- (c) What would be the capacity in litres and the number of bags the container will accommodate?

**END**

NAME:..... INDEX NO 

--	--	--	--	--	--	--	--

SCHOOL:.....

SIGNATURE:.....

241/1

HISTORY AND POLITICAL  
EDUCATION

Paper 1 2024

2<sup>1</sup>/<sub>4</sub> hours



# MEBU EXAMINATIONS CONSULT

## Uganda Certificate Of Education

MOCK ASSESSMENTS 2024

HISTORY AND POLITICAL EDUCATION

PAPER 1

TIME: 2 Hours 15 Minutes

### INSTRUCTIONS TO CANDIDATES:

This paper consists of sections **A** and **B**.

It has **FOUR** examination items.

Section **A** is **COMPULSORY**.

Answer **ONE** item from Section **B**.

Answer **THREE** examination items in **ALL**.

Any additional item answered will **NOT** be scored.

**ALL** answers must be written in the answer booklet(s) provided

Downloaded from www.muutoonline.com, More PASTPAPERS are available

## SECTION A

Answer **ALL** questions in this section

### ITEM 1:

The Nkonko community, led by their respected elder Mr. Wangi, gathers under the shade of a baobab tree to discuss their impending migration to a new location. As they prepare for this significant journey, they grapple with questions about the societal structure they should adopt in their new settlement. As the Nkonko community deliberates on their migration plans, Mr. Wangi poses a thought-provoking question "Dear community members, as we embark on this journey to our new home, it's crucial that we carefully consider the societal structure we wish to establish in the new area"

### Support Material.



### TASK

As a member of the Nkonko community, you have been tasked to give a **Guiding Speech** to the community members as per Mr. Wangi's provoking question.

### ITEM 2



A teacher of history and political education organized study tours for his learners to go and visit various places such as Nyero rock paintings, Amabeere ga Nyinamwiru, Wamala tombs, among others. The teacher wanted the learners to learn more about the history of Uganda through these study tours. On reaching the sites, learners got disappointed when they saw that some of the land that belonged to the sites had been encroached on by the local people. Local people had constructed houses on these sites, opened up large farms, grazed cattle from there as well as cutting down trees from the sites for charcoal burning. The learners suggested that the police should come in and protect such places from the encroachers.

### Support Material

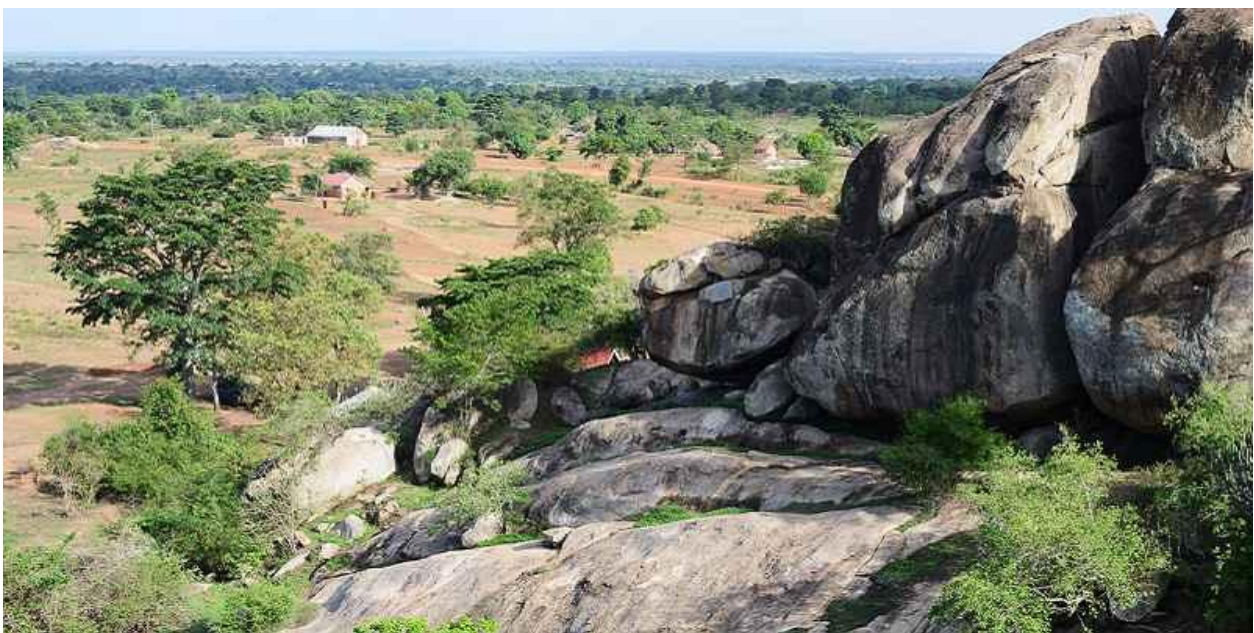

Nyero rock paintings, 29<sup>th</sup> April 2020, Petnah tours

#### Tasks:

- a) Explain reasons why such places should be protected.
- b) What advice would you give to the government of Uganda regarding the best ways of preserving such places?
- c)

### SECTION B

### UNDERSTANDING THE COLONIAL HISTORY OF AFRICA

Answer **ONE** item in this section

### ITEM 3

Erik Prince calls for U.S. to colonize Africa and Latin America, he stated “If so many of these countries around the world are incapable of governing themselves, it’s time for us to just put the imperial hat back on, to say, we’re going to govern those countries” ... because enough is enough, we’re done being invaded. ...You can say that about pretty much all of Africa, they’re incapable of governing themselves.”Those statements have caused tension and opinions diverge, members of the community find themselves at odds over whether to welcome or resist Erik Prince’s idea and others are wondering how such colonial ambitions could be applied within their own community.

#### Support Material.



### TASK

a) As a knowledgeable member of the community, you have been tasked to prepare an **Article** which is going to be published in a Local Community Magazine responding on the concerns of the community about the statements made by Erik Prince.

b)

### UNDERSTANDING THE POST COLONIAL HISTORY AND POLITICAL AFFAIRS OF AFRICA

#### ITEM 4.

In a conference hall in East Africa, government officials, policymakers, and community leaders gather for a symposium on economic development. As they seek inspirational insights to move their region forward, they turn their attention to the remarkable journey of Singapore, Japan and South Korea's economic transformation from a third-world to a first-world nation. As the symposium unfolds, Dr. Adebayo, a renowned economist, poses the following questions: what challenges the achievement of sustainable development and prosperity and what can East Africa emulate from these countries' successes to overcome its challenges.

#### Support Material.



#### TASK

- (a) As a Panelist on the symposium, explain the situation by giving examples from any one Asian country mentioned above.

**END**

NAME:..... INDEX NO: 

--	--	--	--	--	--	--	--

SCHOOL:.....

SIGNATURE:.....

825/1  
ENTREPRENEURSHIP EDUCATION  
PAPER 1  
MOCK 2024  
AUGUST  
TIME:2 HRS:30 MIN



# MEBU EXAMINATIONS CONSULT

## Uganda Certificate Of Education

MOCK ASSESSMENTS 2024

ENTREPRENEURSHIP EDUCATION

PAPER 1

TIME:2HRS:30MINS

### INSTRUCTIONS TO CANDIDATES

- This paper consists of **two** sections **A** and **B**.
- Attempt **ALL** items in section **A**.
- Attempt only **one** item from section **B**.
- Attempt four (**4**) items in all.

Downloaded from www.muonline.com, More PASTPAPERS are available

### ITEM ONE.

In Lugazi town council, Buikwe district, most of the youths are unemployed and spend their time betting. They have advised to form a saving scheme to start any agribusiness because of the many benefits but they are worried of the challenges people face in operating agribusiness.

#### TASK

- a) As a student of entrepreneurship, help them to identify any five types of agribusinesses. **(05 scores)**
- b) Explain the benefits of agribusinesses. **(10 scores)**
- c) Outline the challenges encountered in operation of the business. **(10 scores)**

### ITEM TWO

The government of Uganda is planning to construct a Standard Gauge Railway (SGR) line between Kampala and Kenya which will promote regional trade between the two countries (East Africa). This project shall require large amounts of money to get it finished on time.

#### TASK

- a) Advise the government on the possible sources of funds for the project. **(10 scores)**
- b) How will the government of Uganda benefit after the completion of the project? **(10 scores)**
- c) What challenges are traders likely to face while carrying out regional trade? **(05 scores)**

### ITEM THREE

Keynes bakery started in 1990 and produces different products in the business. During this period, the business was alone in Mubende district. Currently, many bakeries have come up and are competing with Keynes bakery. The customers are running away from Keynes products and one of the reasons given is poor customer care and the employee labour turnover is high.

#### TASK

- d) How can employees of Keynes bakery practice good customer care to customers? **(10 scores)**
- e) Advise Keynes bakery on how to attract and retain the customers to buy its products. **(10 scores)**
- f) Explain the benefits of practising business ethics to the entrepreneurs. **(05 scores)**

## SECTION B

### ITEM 4

You have been given the following information from RICKWO traders for the year ended 31<sup>st</sup>

December 2021

ITEMS	Shs.
Purchases	3,600,000
Sales	5,000,000
Stock (01.01.2021)	600,000
Return outwards	700,000
Carriage on sales	600,000
Return inwards	800,000
General expenses	300,000
Debtors	900,000
Insurance	120,000
Cash at bank	760,000
Creditors	600,000
Machinery	1,200,000
Stock (31 <sup>st</sup> December, 2021)	980,000
Furniture and fittings	480,000
Advertising	100,000
Salaries and wages	1,000,000
Drawings	400,000
Cash in hand	240,000
<b>Capital</b>	<b>sh.4, 800,000</b>

## TASK

- c) From the relevant information, prepare the financial statement that can determine the profit and loss made by the business. **(20 scores)**
- d) Define the financial position of the business. **(05 scores)**

## ITEM FIVE

The following information relates to Mr. Kigoye, a business man in Mpigi for the month Jan, 2020.

1<sup>st</sup> Jan, 2020 Kigoye started business with shs800, 000 as his capital.

3 <sup>rd</sup> bought a machine for cash	shs280, 000
4 <sup>th</sup> sold goods for cash	shs300, 000
8 <sup>th</sup> bought goods for cash	shs350, 000
12 <sup>th</sup> paid insurance in cash	shs180, 000
20 <sup>th</sup> paid electricity in cash	shs240, 000
22 <sup>nd</sup> sold more goods for cash	shs350, 000
25 <sup>th</sup> cash drawings	shs120, 000
30 <sup>th</sup> paid wages in cash	shs130, 000

## TASK

- c) As a student of financial management, help Mr. Kigoye to record the transactions in the relevant ledger accounts and balance them at 31<sup>st</sup> Jan 2020. **(20 scores)**
- d) Prepare a statement that will help him to check the arithmetic accuracy of the ledger balance. **(05 scores)**

**END**

527/1

AGRICULTURE

(THEORY)

MOCK 2024

AUGUST

TIME:2 HRS:30 MIN



# MEBU EXAMINATIONS CONSULT

## Uganda Certificate Of Education

### MOCK ASSESSMENTS 2024

#### PRINCIPLES & PRACTICES OF AGRICULTURE

(THEORY)

TIME:2HRS:30MINS

#### INSTRUCTIONS TO CANDIDATES

- This paper consists of **six** examination items. It has **two** sections A and B.
- Section **A** has **two** compulsory items. Section **B** has two parts: I and II.
- Answer one item from each part.
- Answer **four** examination items in **ALL**.
- Any additional items answered will not be scored.
- All answers must be written in the answer booklets provided.



## SECTION A

### (SOIL SCIENCE AND VALUE ADDITION)

#### ITEM 1.

Your school administration has preference for crops such as maize. Agriculture learners chose to establish a plantation in the school farm. Some areas at the school farm are steep and rocky with shallow soils while other areas are gently sloping with deep, well drained and fairly fertile soils. In the course of running the project, it was observed that the soils were compact, sticky, and flooded with water. The pH of the soil in the nursery is lower than the recommended range for maize growing. The seedlings were thin with shallow roots, bent stems and yellowish leaves.

#### TASK

In your opinion, suggest improvements that Agriculture learners should do to ensure successful maize production on the school farm.

#### ITEM 2

Marvin is a new worker on a dairy farm. He realized that the farm produces lots of milk. The milk gets bad some times and other times, the milk is contaminated due to poor handling. The farm manager is going to be off duty for 2 months and Marvin has been appointed acting manager. Marvin is totally in trouble because he is overwhelmed with the duties ahead of him. He barely has any idea of processing any milk product.

#### a).TASK I

You have visited Marvin on the farm, advice Marvin.

Assuming Marvin has considered your advice and the Farm's board of management would wish to start processing milk products, control milk spoilage, wastages and contamination.

#### b).TASK II

Develop a guide to be used by the farm to achieve this intention.

## SECTION B

This Section has two parts; I and II

### PART I: (ANIMAL PRODUCTION)

Answer one item from this part.

#### ITEM 3

Nankya, a student of Agriculture visited the uncle's farm in **Kiwatule** and in her findings, she indicated that the roof of a calf pen was leaking, the cattle were emaciated and the dung contained worms. The adult animals could hardly find what to eat and were grazing on woody natural pastures. The only source of water had snail shells, algae and dung. The lactating cows had cracks on their teats. Hair like substances was seen in the milk which was filtered using an old cloth. The farm owner uses a basin for mixing the acaricide.

#### ASK

Based on the report from Nankya, how can the farm owner improve on the productivity of the livestock of the Farm?

#### ITEM 4

Lacen is an Agricultural Officer of Gulu district. She visited Opio's rabbit farm at Laroo village. After her visit, she reported that rabbits were found crowded in a simple ground hutch with a roof sheltered with rusty and broken iron sheets. The hutch had no wire netting, light source and had a broken wooden door with a rotten part. Research showed that the hutch was constructed in an open space close to the main road, had dirty feeds and water troughs placed on a damp floor with rotten litter and rabbits had freedom to move out of the structure any time. Lacen's report indicated that rabbits were fed on any kind of food and fermented pelleted feed remains were seen in some dirty feed troughs. In the short period she was at the farm, she observed that the feeding and watering schedule was not strictly followed, rabbits were in poor condition with over grown teeth and worms were seen in their droppings. There was general weight loss, loss of fur and some dead rabbits were seen in cage corners.

**TASK:**

In your view, explain the precautions that Opio should take to ensure profitable rabbit production on his farm.

**PART II: (CROP PRODUCTION)**

**ITEM 5**

Ssempe, a farmer in Kitega village cultivates acreage of five (5). He also owns two other small land fragments in the nearby village. He has over cultivated them to produce more food crops to feed his extended family and improve their standard of living. However, Ssempe grows crops on poor soils with low nutrient content as a result of over cultivation. The soils are exhausted, that he relies entirely on inorganic fertilizers, for nutrients. Recently, Ssempe decided to transform to commercial farming. This has led to over cultivation and extensive use of inorganic fertilizers and mono cropping. Generally, the situation is not good and there is a great decline in crop production.

**TASK:**

As an Agriculture learner with vast knowledge about farming, write a message to Ssempe advising him on how to transform his farming into a modern and more profitable system.

**ITEM 6**

Tukei is a farmer in Mubende, he grows potatoes on one hectare of land. He obtained all the planting materials from his neighbor. The vines had dark spots which appeared as scratches. After clearing the bush using a slasher, Tukei used a dibber to plant and fix the vines. Some of the vines sprouted but others did not. Weeds grew very fast, the potato leaflets were twisted, and stunted growth was observed in some potato plants in the garden. Tukei managed to weed once and decided to harvest the crops after four months using a forked hoe. Most tubers were found rotten and malformed at harvesting. As a result, he obtained only 200 kg of fresh cassava instead of the expected 600 kg per hectare.

**TASK**

Downloaded from www.nutsonline.com. More PAST PAPERS are available

Write a message to Tukei advising him on how to obtain the expected yield.

**END**

Downloaded from [www.mutoonline.com](http://www.mutoonline.com), More PASTPAPERS are available

NAME:..... INDEX NO 

--	--	--	--	--	--	--	--	--	--

SIGNATURE:.....

553/2



**BIOLOGY PAPER 2**

**(PRACTICAL)**

**MOCK AUGUST 2024**

**1 Hours.**

# **MEBU EXAMINATIONS CONSULT**

## **Uganda Certificate Of Education**

**MOCK ASSESSMENTS 2024**

**BIOLOGY**

**PAPER 2 (PRACTICAL)**

**TIME: 2 HRS: 30 MIN**

### **INSTRUCTIONS TO CANDIDATES.**

This paper consists of two examination items. Answer all the items in the spaces provided.

Drawings should be made in the spaces provided. Use sharp pencils for drawings.

Coloured pencils or crayons should not be used.

No additional sheets of writing papers are to be inserted in the booklet.

### **ITEM 1**

In Gayaza, there existed a woman by name of Winnie who had a family of about six children. One of her children, Prossy, a S.2 student at one of the secondary schools in the area went to the sickbay while at school and asked the school nurse, Rachael to examine her due to the fact that she



**ITEM 2.**

Mr. Lubwama is a Receptionist at Acumen computer company Limited. Every week on a daily basis, he branches to **ABC** Training and fitness center and usually carries **50** Kilogram weights. Due to this, Mr. Lubwama started feeling pain in the neck, chest and the lower abdominal regions. The combined pain from the three regions has made him unable to effectively perform his duties while at the work place. He decided to visit Makerere Health Centre for thorough examination by medical doctors in order to identify what his challenge could be .After thorough examination, the





(c).Make a well labeled drawing of the posterior view of specimen **N2** to enable Mr. Lubwama identify the parts it possesses.

Downloaded from www.mutoonline.com, More PASTPAPERS are available

(d).Help Mr. Lubwama understand the parts that make up the anterior view of specimen **N3**.



END

Tel.0709843314 / 0761762094

Downloaded from www.muonline.com, More PASTPAPERS are available

527/2

AGRICULTURE

(PRACTICAL)

MOCK 2024

AUGUST

TIME:2 HRS



# MEBU EXAMINATIONS CONSULT

Uganda Certificate Of Education

MOCK ASSESSMENTS 2024

PRINCIPLES & PRACTICES OF AGRICULTURE

(PRACTICAL)

TIME:2HRS

## INSTRUCTIONS TO CANDIDATES

- This Paper consists of **TWO** compulsory items.
- Write your answers in the spaces provided using blue or black pen ink



**ITEM 2**

Milk consumers from Rwakitura complain alot about poor quality of milk supplied in the market. Farmers usually add water to milk to increase its volume to earn extra profits. They also add flour to make milk thick and dense. Such practices reduce the quality of milk and pose a health risk to consumers. Food safety and standards authority decided to collect milk samples **O, P** and **Q** from different milk collection centers to check the quality and sustainability of each for marketing.

**Task**

Using science process skills determine the quality of milk samples **O, P** and **Q** and make recommendations to the farmers and consumers respectively.

- a) Complete the investigation and present your report.

Downloaded from www.nutoonline.com, More: PASTPAPERS are available

**THE END**  
**0709843314 & 0761762094**

840/1

INFORMATION AND  
COMMUNICATIONS  
TECHNOLOGY (ICT)

Paper 1(Theory)

August 2024

2 Hours 15 Minutes



# MEBU EXAMINATIONS CONSULT

Uganda Certificate Of Education

MOCK ASSESSMENTS 2024

INFORMATION AND COMMUNICATION TECHNOLOGY

Paper 1(Theory)

2 Hours 15 Minutes

## INSTRUCTIONS TO CANDIDATES

- ✓ This paper consists of **two** sections; **A** and **B**. It has **five** examination items.
- ✓ Section **A** has **one** compulsory item.
- ✓ Section **B** has **two** parts; **I** and **II**. Answer **one** item from each part.
- ✓ Answer **three** examination items in **ALL**.
- ✓ Any additional item(s) answered will **not** be scored.
- ✓ **All** answers **must** be written in the answer booklet(s) provided.



## SECTION A

Answer the item in this section.

Downloaded from www.mutsonline.com, More PASTPAPERS are available

### ITEM ONE.

In the recently concluded enumeration exercise conducted by the Uganda Bureau of Statistics (UBOS). Being a national wide duty, it involved very many stakeholders including but not limited to, census enumerators, supervisors, Census District Officers, Police, CAOs, leaders at the sub counties, municipalities and village chairpersons. Each supervisor was given a complete computer set with all the required peripherals, each census enumerator was given a data collection capturing tool to assist in the proper capturing and recording of peoples' details. Unfortunately, many supervisors and census enumerators had no enough training on matters pertaining the use of these ICT tools. UBOS held training of its team at sub county level across the country. You were contacted by UBOS to help in the training of the supervisors and the enumerators about assembling, usage and the importance of the required ICT tools. Your telephone contact was shared amongst the trainees to call you in case any challenges arose.



### TASK:

- In a write up, show how the supervisors and enumerators were able to assemble the different parts of a computer system to come up with a functioning computer.
- Underline the measures that were undertaken to ensure that the tools used were in the continued good working state.

## SECTION B

This section has **two** Parts; **I** and **II**.

### Part I

Answer **one** item from this part.

#### ITEM TWO.

You have been appointed as the IT coordinator at Makerere University and you are responsible for managing the lifecycle of thousands of electronic devices, including computers, tablets, and smart phones. The institution is committed to sustainability and reducing the environmental impact.



#### TASK:

- (a) Develop a comprehensive management plan that the university can use to reduce on the environmental impact of these aging devices.
- (b) Advise the university on which measures they can undertake in the disposal of the same in an environmentally responsible manner.

#### ITEM THREE.

Education High school stores student records, including personal information, academic performance, and health data on the cloud based system. Recently, there have been concerns about

the system's security particularly after Truth High school, a neighboring school experienced a data breach. As network security expert, you have been assigned the role to ensure the school data is safe from these breaches.

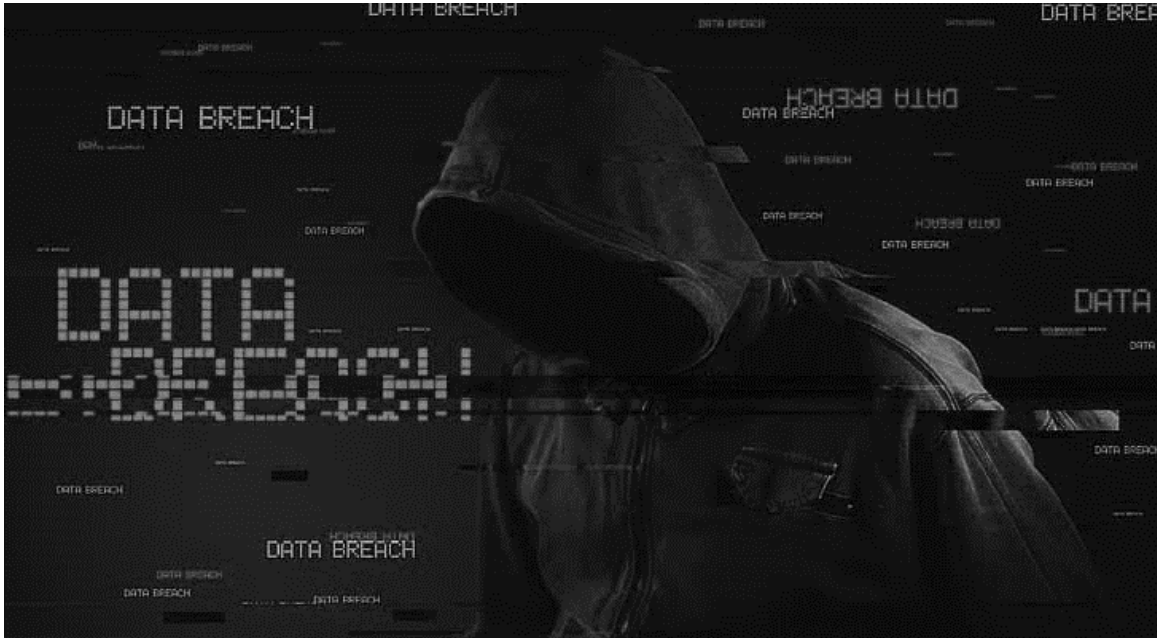

*Source: [www.wallpaperflare.com](http://www.wallpaperflare.com)*

**ASK:**

- a) Advise on the steps the school should undertake to ensure that the school data in the system is secure.
- b) Educate the staff and students on how relevant it is to ensure data privacy and the risks associated with data breaches.

## **Part II**

**Answer One Item From This Part.**

### **ITEM FOUR.**

The MONEY CLUB is a new club joined voluntarily by employees of Sena General Hardware willing to change their financial and social status. In a meeting held at the start of the year, club leaders were elected as follows; Mr.Kiggundu K(chairperson),Namuddu R(secretary), Naluwagga E (Treasurer), Njogedde A (marketing). The minutes of the meeting were recorded in a 32 page Picfare book by the club secretary. Members' contributions and membership fees were recorded by the treasurer in another physical ledger. The secretary also recorded the details about members in another book entitled "Money Club Information.", the marketing officer also prepared

information in different pages to be uploaded such that other members can search about the club activities and its membership. All the above information was given to the chairperson so that he can make a presentation to the Centenary bank loan officer Rubaga branch. On reaching the bank, the chairperson was quickly advised by the loan officer to go back and use a computerized system so that he can hand in both a soft copy to the official bank email and a hardcopy to the branch manager.

The chairperson has invited you to guide him in coming up with both a hardcopy and a softcopy of the club documents.



Source: [www.wallpaperflare.com](http://www.wallpaperflare.com)

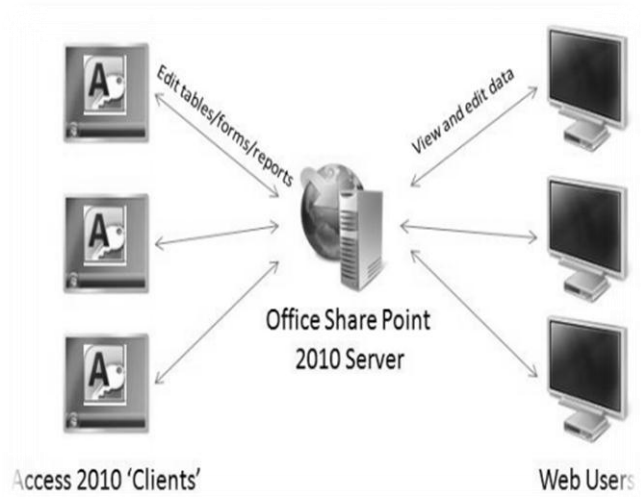

## TASK

- Prepare a write up to the chairperson of the club containing different computerized software and how they can be used to by the elected club leaders.
- Demonstrate to the chairperson the steps taken to send the softcopy to the official bank email ([info@centenarybank.co.ug](mailto:info@centenarybank.co.ug)).

## ITEM FIVE.

It has been a long journey of four years in this academic battle. In your school, a leavers' party is a must in each and every year. The leavers' party organizing committee was elected during the Friday class meeting led by your class teacher. Many of your classmates are excited about the party and some of them are even willing to participate in the miming of their favorite songs. A list of these songs has been collected by the secretary organizing committee. It contains songs such as

Omwoyo, Masavu, Mbimalanga, Katonda yabadde mweno ensonga, Mai by B2C, Kani and Ampisizzaawo by Judith Babirye among others. You are already on stage performing and the audience seems to be won over by your lyrics, accent and the vibe. Out of the blue, power goes off and there is total silence in the main hall. A standby generator was started and the DJ seems to be lost from the last stop. You quickly invite your friend to rush to the nearby music shop to carry your songs so that you can perform again.



Source: [www.wallpaperflare.com](http://www.wallpaperflare.com)

Task:

- Provide a list of devices/media/technology you are likely to use to transfer your favorite music from the music shop to the party hall.
- Guide the music shop attendant on the steps required to transfer the songs from his computer to the tool available for transferring the songs.

**END**

840/2

INFORMATION AND  
COMMUNICATIONS  
TECHNOLOGY (ICT)  
PAPER 2

MOCKS 2024

AUGUST

2½ Hours



# MEBU EXAMINATIONS CONSULT

## Uganda Certificate Of Education

### MOCK ASSESSMENTS 2024

INFORMATION AND COMMUNICATIONS TECHNOLOGY

Paper 2 (Practical)

2 Hour 30 Minutes

#### INSTRUCTIONS TO CANDIDATES:

- ✓ This paper consists of **two** examination items.
- ✓ Answer **Both** items in this paper.
- ✓ You are provided with support files in the folder **MEBU CONSULTS Support Files** in the default my documents. Use the support files where applicable to supplement the items.
- ✓ You are provided with a **New Blank Compact Disc (CD)**.
- ✓ Use a **Permanent Marker** to write your name, random number and personal number on your CD.
- ✓ You should continuously **save** your work.
- ✓ You **must** produce a **Hard Copy** for each of your work to accompany a soft copy on the Compact Disc (CD).

## ITEM 1.

A group of citizens in one of the villages in **Luweero** never got involved in the census activity. The Uganda police force further investigated and arrested them due to their disobedience. The officer in charge of the station later on prepared warning letters which were sent to the relatives of the suspects in a support file **Mbuzi Ekogga.docx**. Many Ugandans have a hope to see a greater change in planning by the government because of the activity. John, a computer illiterate approached one of the enumerators to know the actual population of his Sub County called **Omwavu wa Kuffa** before it is sent to UBOS but unfortunately, all the process was done online using computers which would not be easy to access all the data at his convenient time. The records from the enumerator were provided in support file **Uganda 2024.xls** with their Identity and Bio data provided in the file **Kimala.docx**.

### Task:

Using the support files provided;

- Design an electronic storage of the data and use it to prepare a graphical representation of the records.
- Generate a message that will be sent to the suspects' relatives.
- Generate the overall amount that will be charged to each person due to disobedience and create an object which will be used to populate the data.

## ITEM 2.

In Mbiiko Village, there is a saving group where members are not contented on how sometimes their profits fail to accumulate. It has been observed that **Ndombolo**, the chairperson of the group doesn't often update the members on the accumulation of their money. One of the elites in the village requested the group to design a program which will keep updating the new members in the group and also help the new members to join the saving group. But unfortunately due to the chairperson's ideology on how internet and other social media platforms are sources of hackers, he requested to have an orientation on how it can be achieved effectively.

One of the founders of the saving group proposed to have an **active form** for the new members who would wish to be part of the saving group.

### Task

Generate an online platform that provides feedback to the founder of the saving group on how to address the concerns of the group members. A support folder called **MEBU-Uganda** has been provided.

**END**

612/1

ART AND DESIGN

Paper 1(Theory)  
Art History and Studio Technology)

MOCKS 2024

AUGUST

Hour 40 Minutes



# MEBU EXAMINATIONS CONSULT

## Uganda Certificate Of Education

### MOCK ASSESSMENTS 2024

ART AND DESIGN

**Paper 1 (Theory)**

Art History and Studio Technology

1 Hour 40 Minutes

### INSTRUCTIONS TO CANDIDATES

This paper consists of two sections; **A** and **B**. It has **four** examination items. Answer **one** item from each section.

Answer **two** examination items in all.

Any additional item answered will **not** be scored.

**All** answers **must** be written in the answer booklet(s) provided.



## SECTION A: Art History

### Either

#### ITEM 1

The school has organized an art tour to Rome to explore the different art works that were done in the past to get ideas that could be developmental for our projects we are planning to do next term. The school has chosen three students of the art class to go and explore Rome and come back to tell the rest of the students. Below is what they found out in the museum of Munich that took their attention



Fig. A

However, on reaching there they consulted the curators about the art work in Fig A and asked about how it was made and how it came into its existence.

#### TASK

Assuming the school chose you to be among the three students who went to Rome and you came back with a package to deliver to your fellow students, produce a write up that could be relevant to the students about the art work in Fig A above.

Or

**ITEM 2**

There was a debate between your school and another school on the decorative artworks that were done by the Greeks in the ancient period of Corinthians. The debate was about the characteristics of the Red and Black figures that were so dominant in Greek production of artworks. Below are some of the support images to guide the debate in Fig A and Fig B

Downloaded from www.mutoonline.com, More PASTPAPERS are available



**Fig A**



**Fig B**

However, your school was the first one to present and analyze the characteristics of the red and black figures and they chose you to be the first presenter of the debate.

**TASK**

Assume the school entrusts you to present what you have discovered about the red and black figure paintings and they require you to present a write up eulogizing everything to the debate. Present the write up.

## SECTION B: Studio Technology

Either

TEM 3

The head teacher tested one of his S.4 art students with the artwork he bought from the known art gallery in Kampala “**Michael Angelo**” to come and describe the art work to the rest of the students in the school because the art work was very confusing before him and wanted to get an art student for help and give him/her a reward after describing it. Below is the support image the Head Teacher bought from the gallery.



FigA

## TASK

Randomly, the Head teacher selects you to come and describe the artwork in Fig A above to the rest of the school and get your reward. Prepare a presentation which you will use to guide the students.

Or

## ITEM 4

Our art teacher took us for a tour to the art galleries here around Kampala and our first place was Kyambogo ceramics studio where we found a potter who works there and was busy making pots and vases. We found some done art pieces around but of different techniques and we were amazed of how it's being done.



Fig A



Fig B

However, the potter paused us a question, asking “according to the knowledge you have attained from the school, let one of you explain the techniques of how these ceramic or pottery pieces are produced.”

## TASK

Assuming, the potter selects you to explain how those potteries are produced, present a very good presentation to him.

**END**

612/2



ART AND DESIGN

Paper 2 (Practical)

Art Making-Practical

MOCKS 2024

AUGUST

TIME: 4 HRS

# MEBU EXAMINATIONS CONSULT

## Uganda Certificate Of Education

### MOCK ASSESSMENTS 2024

ART AND DESIGN

Paper 2

Art Making-Practical

TIME: 4 HRS

### INSTRUCTIONS TO CANDIDATES

This paper has **one compulsory** examination item. This paper will be done in **two** sessions;

- (i) Planning Session (1 hour- Morning)
- (ii) Production Session (3 hours – Afternoon).

Bulky materials such as cement, clay, stone, hard wood or materials which may lose the intended shapes and forms should be avoided.

Avoid using materials which may easily decompose in the process of transportation from the school to marking centers.

Read the scenario provided and then answer accordingly using the appropriate materials and tools to generate a suitable artwork/form.

Note:

Your product/work may be generated from any discipline of Art and Design for as long as it is in the direction of the scenario give.

## Art Making (Practical)

### ITEM 1

There is always an annual exhibition that takes place in December and it collects different artists across the world that come to critique and appreciate the local artists' work. The organizers of the exhibition sent a call to every artist to produce their master piece in either 2D or 3D for the exhibition. The final piece should be well presented in either pencil or colors to match the quality of artworks to be exhibited on that day.

### ASK

As an art student or artist in the school, produce any art work of your preference that will be suitable for the annual art exhibition.

**END**

Downloaded from [www.intoonline.com](http://www.intoonline.com), More PASTPAPERS are available

208/1

Literature in English

Paper 1

MOCK 2024

AUGUST

Time: 2 Hrs: 30 Mins



## MEBU EXAMINATIONS CONSULT

### Uganda Certificate Of Education

MOCK ASSESSMENTS 2024

LITERATURE IN ENGLISH

PAPER 1

TIME: 2HRS:30 MINS

#### INSTRUCTIONS TO CANDIDATES

This paper consists of **three** examination items. It has two sections, **A** and **B**.

Section **A** has **one** compulsory item.

There are **two** examination items in section **B**. Answer one item.

Answer **two** examination items in all.

Any additional items answered will not be scored.

All answers must be written in the answer booklets provided.



## SECTION A

**Item 1. Read the passage below and then answer all the tasks that follow.**

In the dimly lit alley, the flickering streetlights cast eerie shadows on the walls as the rain poured down like a relentless curtain of sorrow. The smell of wet earth and decay filled the air, a morbid perfume that clung to the skin like a bad omen. Amidst this bleak backdrop, a lone figure emerged, shrouded in a tattered coat that seemed to swallow their frame whole. Their eyes, sunken and haunted, darted about with a mixture of fear and desperation, like a trapped animal searching for an escape route.

As they navigated the treacherous terrain, the sound of distant laughter echoed through the alley, a cruel mockery that only served to heighten their sense of isolation. The figure's thoughts swirled with the fragmented memories of a life left behind, like shards of broken glass that refused to be swept away. And yet, with each step forward, they felt an inexorable pull towards the unknown, a siren's call that beckoned them towards the abyss.

- a) How does the author use sensory details to create a vivid atmosphere in the passage?
- b) What symbolism can be inferred from the use of shadows, rain, and decay in the setting?
- c) Analyze the characterization of the lone figure. What emotions and motivations are conveyed through their actions and appearance?
- d) What literary device is employed in the phrase "a morbid perfume that clung to the skin like a bad omen"? Explain its effect.
- e) How does the author use foreshadowing to hint at the figure's fate? Provide evidence from the passage.
- f) What themes are explored in the passage? Support your answer with textual evidence.

## **SECTION B**

Choose one task from this section. Illustrate your answers by referring to any of the following set books;

- FRANCIS IMBUGA: The Return of Mgofu

- VICTOR BYABAMAZIMA: Shadows of Time
- CHINUA ACHEBE: Things Fall Apart
- DAVID RUBADIRI: Growing up with Poetry
- OKIYA OMTATAH OKOITI: Voice of the People
- A.D. AMATESHE: An Anthology of East African Poetry
- LAWRENCE DARMANI: Grief Child
- DANIEL MENGARA: Mema
- JOHN STEINBECK: The Pearl
- SYLVESTER ONZIVUA: The Heart Soothers
- WILLIAM SHAKESPEARE: The Merchant of Venice

**Either**

**Item 2.**

Numerous authors write differently about personal enfeeblements which have an impact on the different personal traits and the entire community as a whole. In relation to any of the above mentioned books that you could have studied, describe the different enfeeblements that the author exposes.

**Or**

**Item 3.**

Lutaaya is your fellow s.4 student in the literature class. All your fellow classmates have found it hard to associate with him because of his anti-social behavior. They have approached you and have requested you to kindly talk to him such that he can change.

**Task.**

As a literature student, refer to the scenarios and traits exhibited in anyone of the set books to advise him on how he can become accessible to all fellow literature students of your class.

**END**

P335/1

Luganda Paper 1

(Okuwandiika embooji

n'okukyusa)

MOCK 2024

AUGUST

Essawa: Bbiri.



# MEBU EXAMINATIONS CONSULT

Uganda Certificate Of Education

MOCK ASSESSMENTS 2024

**LUGANDA**

Olupapula Olusooka

Okuwandiika Embooji N'okukyusa

Essawa: Bbiri.

## EBIGOBERERWA

- Olupapula luno lugabanyiziddwamu ebitundu **bibiri: A ne B.**
- Lulimu ebibuuzo **bisatu.**
- Mu Kitundu **A** mulimu nnamba bbiri, kolako **emu:1(a)** oba **(b).**
- **Mu kitundu B** mulimu ennamba emu era ya buwaze.
- Ddamu ebibuuzo bibiri awamu.
- Ebibuuzo ebissuka mu by'olagiddwa tebijja kukeberwa.
- Ebyokuddamu biwandiike mu mpapula ezikuweereddwa

## **EKITUNDU A**

*Kola 1 (a) oba (b).*

1. (a) *Soma akatundu kano wammanga n'oluvannyuma owandiike embooji ya bigambo 350-400.*

abadde okolera mu Wooteeri y'omugagga omu mu kibuga era ng'ofunayo ku ssente ezikuyamba okufuna ebyetaago by'essomero muzadde wo by'atasobola kukutuusaako wabula ambeera mu wooteri eyo ekufuukidde omuteego era oyagala ebyokuklera omugagga oyo byamuke. Muzaddewo aledmeddeko tayagala ove mu wooteri eyo kubanga ye agamba taja usobola kukuwa bisale bya ssomero na byetaago. Wandiika ng'onnyonnyola muzadde wo bizibu by'osanga ng'oli mu wooteeri eyo ebikukaluubirizza omulimu ate omuwe amagezi ku ngeri ndala ze muyinza okufunamu ensimbi ezikuyamba ezisinga ku mulimu gw'akukaka okukola.

### **OBA**

b) *Soma embooji eno wammanga n'oluvannyuma owand iike embooji ya bigambo 150 ku 200.*

Vakuliramu ekikwekweto ekyaggala amasomero g'obwannanyini mu ggombolola ya Ndikuttamadda naye nga ate amasomero ago gabadde gayamba nnyo abaana mu ggombolola yo.

Ita abatwala amasomero ago ge mwagala obannyonnyole ebintu bye mwasinziirako okuggala amasomero gaabwe era obawe amagezi ge muyinza okukozesa mu ggombolola okulaba ng'amasomero ago gatuuka ku mutindo ogw'okuweereza obulungi okutuukiriza ebigendererwa by'ekitongole ky'ebyenjigiriza.

## **EKITUNDU B**

2. Mukyazizza abagenyi okuva e Bungereza era bavudde mu bitundu bya Wales. naye abakadde abakulu abaliwo bonna tebamanyi lulimi Lungereza naye bambi baagala okumanya akuliddemu abagenyi by'ayogedde. Yamba abakadde bano basobole okutegeera ebyogeddwa.

## HUMAN RIGHTS

Downloaded from www.stuvia.com. More PAST PAPERS are available

Human rights are rights are supposed to be enjoyed by all human beings, regardless of race, sex, nationality, ethnicity, language, religion, or any other status. Human rights include the right to life and liberty, freedom from slavery and torture, freedom of opinion and expression, the right to work and education, health and many more. Everyone is entitled to these rights, without discrimination.

International human rights law lays down the obligations of Governments to act in certain ways or refrain from certain acts, in order to promote and protect human rights and fundamental freedoms of individuals or groups.

One of the great achievements of the United Nations is the creation of a comprehensive body of human rights law that is a universal and internationally protected law to which all nations can subscribe and all people aspire. The United Nations has defined a broad range of internationally accepted rights, including civil, cultural, economic, political and social rights. It has also established mechanisms to promote and protect these rights and to assist states in carrying out their responsibilities. Since then, the United Nations has gradually expanded human rights law to encompass specific standards for women, children, persons with disabilities, minorities and other vulnerable groups, who now possess rights that protect them from discrimination that had long been common in many societies.

**BIKOMYE WANO**

P335/2

Luganda Paper 2

(Okusoma Bwino,

Okufunza N'ebuyobuwangwa)

MOCK 2024

AUGUST

Essawa: Bbiri N'ekitundu



# MEBU EXAMINATIONS CONSULT

Uganda Certificate Of Education

MOCK ASSESSMENTS 2024

**LUGANDA**

Olupapula Olw'okubiri

Okusoma Bwino, Okufunza N'ebuyobuwangwa.

Essawa: Bbiri N'ekitundu (2 Hrs: 30 Min)

## EBIGOBERERWA

Olupapula luno lugabanyiziddwamu ebitundu bisatu **A, B, C**.

Awamu mulimu Olupapula ebubuizo bina

Ekitundu **A** ne **B** bya buwaze

Mu kitundu **C** mulimu ebibuuzo bibiri. Kolako kimu kyoka. Kola nnamba **3** oba **4**.

Ddamu ebibuuzo bisatu byonna awamu.

# EKITUNDU A

## (Ekitundu kino kya buwaze)

1. Soma ekintundu kino wamanga oluvanyuma oddemu ebibuuzo ebikuwerwedwa ku nkomerero yaakyo.

Pulezidenti agguddewo olusirika lwa baminisita, abawandisi b'enkalakkalira n'olukiiko lwa NRM olwa CEC n'alangirira nga bwataddewo ebitongole ebirala bibiri okwongera okulwanyisa buli bwenguzi. Olusirika luno lwaguddwawo eggulo ekyankwanzi lwakumala ennaku ttano nga batunuulira entambula y'emirimu bukya balondebwa mu 2021 nga basinziira ku bye baasuubiza abalonzi mu kisanja kino.

Museveni yagambye nti ba Gavumenti abavunanyizibwa okukuma ssente z'omuwi w'omusolo e basinze okumuyiwa kyoka n'agamba nti ekitatta muyima nga bwe kitamumalako nte nze, naye si waakuweera okutuusa ng'awagudde ekizubu ky'obuli bw'engunzi (obukenuzi). Yagambye nti agenda kutondawo ebitongole ebirala bibiri okuli ekya Anti-Tax collection investigation ekirwanyisa ababba omuslo awamu n'ekirala ekya **Accountant and Audit Unit** nga nakyo kirondoola nkola ya mirimu. Ebitongole ebyo bigenda kuyamba okukwataganya obuterevu emirimu kuba yakizudde nga ssente nnyingi zibula mu bintu birala.

Museveni yasabye baminisita babeere basaale mu kulwanyisa ekizibu kino kuba ebisinga nikoleddwako nga eguzi yokka kati yeeremeseza Uganda okufuuka ensi eyeeyagaza. Olusirika luno olwokumala ennaku lugenda kubeere wansi w'omulamwa ogugamba nti: **Okwanukula omulanga gwa bannaansi ku buweereza obunaavaamu enkulaakulana y'embeera n'ebyenfuna.**

Omuwandiisi wa kabineeti era akulira abakozi ba Gavumenti Lucy Nakyobe yagambye nti luno lwe lusirika lw'ekika kino olusookedde ddala Gavumenti okwekubamu toozi mu bintu by'ekoze.

Olusirika luno lugenda kutyamba okwekubamu toozi tulabe ebitambula obulungi , ebitatambula bulungi , ebikireese n'ebirina okukolebwa okutereza obuweereza awamu n'obuvanaanyizibwa ku mbeera eyo."Nakyobe bwe yagambye. Bwe banaamala okuddamu ekibuuzo ebyo waggulu, bajja kusomesa abakulembeze n'abatekesa mu nkola kye balina okukola .

Gye buvuddeko Pulezidenti yategeeza nti Kaliisoliiso wa Gavumenti nti eggwanga lifirwa obuwumbi 10,000 buli mwaka mu buli bw'enguzi pulezidenti ebiseera bino ayongendde amaanyi mu lutalo lw'okulwanyisa enguzi era nga waliwo n'abaka ba palamenti abakwatibwako ku nsonga y'okusaba ssente basobole okuyisa ssente mu Bajeti y'omwaka guno!

**(Bisimbuddwa mu Bukedde Lwakubiri, kasambula, 09- 2024).**

**Ebibuuzo.**

- a) Eggwanga ery'okumuliraano wano e Kenya bakubye olukungana lw'abakulembeze ekkomo ku buli bw'enguzi. Weeyambise ekitundu ekyo ky'osomye obawe amagezi ku ngeri gye bayinza okulwanyisa enguzi.
- b) Munno aloneddwa ng'omuwandisi wa kabineeti. Weeyambise ekitundu ky'osomye omuwe ku amagezi ku bigambo by'anategeeza bannamaulire ku lusirika lw'akubakulembeze olwayitiddwa kyankwanzi.
- c) Mukwano gwo yakalondebwa ku bubaka bwa palamaenti. Sinziira ku kitindu ky'osomye omuwe amagezi aleme kutwatibwa.
- d) Oweeredwa obuvunaanyizibwa okwogerako n'abaka ba palamanti abalina empisa eziringa ezaabo b'osomyeko mumkitundu ekyo. Wandiika ng'obabuulirira basobole okweddako bakyuse mu nneeyisa yaabwe.

## EKITUNDU B

### (Ekitundu kino kyabuwa)

**Wasabiddwa** okukiikirira ekibiina kyammwe eky'abalimi mu musomo ogwategekeddwa okusomesa abalimi ku ndwadde ezitawaanya ennyo ebitooke; Weeyambise ekitundu kino mwammawanga otegeeze balimi banno mu bufunze bwa bigambo nga 100 ebyo bye mwasomye.

Obulwadde obuletera ebitooke okuwotoka obusiinga okuba obw'omutawaana wano mu Yuganda bwa mirindi ebiri. Waliwo obuletebwa obuwuka bwe tuyita Bacteria n'bwo obuletebwa obuwuka bwe tuyita Fungusi. Obulwadde buno obw'ebitooke busiinga kusaasaanyizibwa njuki okuva ku mpummumpu z'ebitooke ebirwadde ne zidda ku bitooke ebiramu nga zinoonya omubisi ogusangibwa bimuli by'empummumpu ne bugenda okubuna ekikolo kyonna.

Ebitooke ebikwatibwa obulwadde buno oluvannyuma bifa. Bwe kityo osaana okusala empummupu ku matooke agaakassa amangu ddala ng'ebiwagu byakakyusa okutunula waggulu. Kw'olabira ebitooke ebikwatiddwa obulwadde buno, amatooke agaba gasizza gengerana natobotobo nga teganakula bulungi nga gakyali mato. Ebitooke ebirwadde bw'obisalamu munda waabyo biraga langi eya kyenvu oba kitaka ate nga bivaamu engeri yamasira. Endagala nazo zeengeera era nga mpotofu.

Ebitooke ebirwadde mu ngeri eno, osaana okubisima oba okusigula amangu ddalanga waakamala okuzuula obulwadde. Enkolokolo zonna ozimalirayo ddala obutasobola kuleeta nsukusa ndala. Byona ebitundundu by'ebitooke ebisiguddwa, enkolokolo n'ebirala obyokya, ebirala obiziika bulungi mu kinnya obutalekaawo kantu konna mu lusuku.

Ebintu ebyo byonna by'akozesa mu kusigula n'okutemaatema ebitooke ebirwadde, osaana okubiyonja obulungi nga taddamu kubikokozesa.

Ate ekirala, osaana okwewalira ddala okuggya ebitooke, ensukusa oba endalagala mu kifo oba mu kifo mu lusuku omuli obulwadde n'obitwala oba mu kifo mu lusuku omutali bulwadde.

Obulwadde buno tebunnaba kufunirwa ddagala lya kubuwonya. Okunoonyereza kukyagenda mu maaso. Ebyo nga bikyali bityo osaana okulaba ng'olusuku lwo lulabirilwa bulungi mu ngeri zonna nga ennima ey; omulembe bwesaana okubeera. Era n; okulambulanga buli kiseera n; okusigula ebitooke ebirwadde amangu ddala ng'obulwadde bwakazuulibwa nga tebunaba



kusaasaanira bitooke birala mu lusuku lwo. Ng'omuntu

eyeerebirira obulungi ate nga'alya bulungi bw'atagonzebwa bulwadde nga bumukutte,  
butafaanana n'oyo ateeafaako

**Bisimbuddwa mu Ntanda ya Buganda nnamba 16 Ntenu 2008)**

### EKITUNDU C

**Ddamu ekibuuzo kimu ku bikuweereddwa wammanga.**

5. **Omuwala** Nantumbwe muliranwa wammwe bagamba mbu osiiwuuse nnyo empisa kyoka ate mukwano gwo era nabasomesa ku ssomero bagamba mbu takyawuliriko ddala wadde n'akatono. Nnyina agamba nti afubye nga kwasobola okubuulirira enneeyisa y'omwana omuwala naye agaanye okukyuusa. Gwe nga mukwano gwa Nantumbwe yogerko naye ku ngeri entuufu gy'asanidde okweyisaamu ngw'omwana w o'buwala.

**Oba**

Mu kuziika kojja mmwe,walaba nga mukuluwo amuwujjama embooko nnya era kino kyakwewuunyisa nnyo ne weebuuza ensonga eyaviriddeko mukuluwo okukuba kojja wammwe . Wanduka za mbwa ewa jjajjawo era n;omubuza ensonga lwaki ekintu ekyo kyali kikoladdwa!Yakutegeez nti eyo mpissa ya buwangwa ekolebwa omujjwa singa omufu aba aganye okumuziika oba ng'ateesewo embeera. Oluvanyuma yakubuulira ne ku mirimu wamu n'obuvanayizibwa obulula mmwe abajjwa bwe mukola wano mu Buganda. Kati wandiika ng'onnyonnyola botoobo abataaliyo ku ebyo jjajja mwe bye yabategeeza.

**BIKOMYE WANO.**

336/2

KISWAHILI

PAPER 2

(UFAHAMU NA

UCHAMBUZI WA FASIHI)

MOCK 2024

AUGUST

2HRS



# MEBU EXAMINATIONS CONSULT

Uganda Certificate Of Education

MOCK ASSESSMENTS 2024

LUGHA YA KISWAHILI

UFAHAMU NA UCHAMBUZI WA FASIHI

MASAA: MAWILI (2HRS)

## MAAGIZO KWA WATAHINIWA

Karatasi hii ina sehemu mbili; A na B

Mtahiniwa lazima ajibu maswali yote.

## SEHEMU A (UFAHAMU)

**ITEM 1.**Soma habari hii kisha ujibu maswali yatakayofuata.

### **KIANGAZI WILAYANI ISINGIRO.**

Hapo zamani za kale, paliishi mzwee Kazimoto na mkewe Bi. Haraka katika wilaya ya Isingiro. Walikuwa na mali nyingi na pia , walikuwa na watoto watano wavulana tu. Kila wakati muda wa jioni, wenyeji katika wilaya hii wangewakuta wakipigana katika aila yao. Isitoshe, wavulana wao kazi yao ilikuwa kulima kila siku kuanzia asubuhi mpaka jioni bila hata kupewa chakula, wazazi wao kazi yao ilikuwa kunywa pombe tu na kuuza mahindi na ndizi kwa sababu wavulana wao walikuwa na bidii katika ukulima.

Baada ya miaka mitano ya chakula kingi kwa familia hii,kiangazi ilitokea iliyochukua muda wa miaka kumi.katika wakati huu, kila sehemu ya Isingiro ilikauka na maji bei yake ikapanda juu sana. Bwana Kazimoto aliendelea na pombe pamoja na mkewe Bi. Haraka.Katika msimu huu hakupata mahindi kama misimu mingine ila mahindi yote ilikauka kwa sababu ya jua kali mno,kufika kiwango cha kutovuna hata kilo mbili nyumbani.

Kwa upande wa ndizi,kimbunga iliharibu kila kitu yaani ndizi zilizokuwa tayari kutolewa shambani zilianguka chini puuuuuu! bila kuacha hata moja juu na pia jua kali liliivisha zile ndizi zile karibu na zote. Hawakupata hata mbili za kuuza kwa huo msimu.Familia iliendelea kuwa vibaya wakati ambapo **walikuwa wanalalia mate** hadi asubuhi kuendelea kwa muda wa miaka mitano. Kila wakati wangeona mawingu lakini hawangeona mvua na wanawake wajawazitowakifikia kiwango cha kutembea kama Adam kwa sababu ya jua kali kwani Isingiro iko karibu na Ikweta.

Mzee alitafuta vijiti virefu vya kumsaidia katika shamba lake la ndizi lakini nguvu zake hazikufua dafu.Isitoshe,wavulana waliamua kukata miti ili wachome kupata makaa.Walifanya na kufaulu kupata magunia kumi na moja. Baadaye, waliuza na kupata pesa zao na kumnyima baba yao pesa hizi , kilicho mkasirisha na kuwafukuza wavulana wake wote nyumbani. Muda si muda kama waswahili walivyosema kuwa **sikio la kufa halisikii dawa**, wavulana wote walitoroka nyumbani kwao na kufungua ukurasa mpya wa maisha kivyao kwa kutumia hizi pesa.

Mzee naye kwa upande wake, akaanza kukorofishana na mkewe akamtoa sikio moja baadaye jicho na kumkata mguu kama wahenga walivyosema kuwa **usipoziba ufa, utajenga ukuta. Mzee alimkatisha roho mkewe na kubaki kama padre kwa nyumba yake.**Mzee akaendelea na maisha haya mabaya ,kuoga kwake kulikuwa **kama kula nyama ya nguruwe kwa waislamu msikitini.** Vilevile, kuvaa nguo kwake kulikuwa ni **kama kuingia msikitini na viatu** na pia kula chakula kwake kulikuwa ni kama **kuoa kwa kasisi kanisani.**

Ingawa maisha yalikuwa hivyo ,hali hii akaitilia pamba masikioni. Wahenga **walisema cha kuvunda hakina ubani,** Mzee alienda kwa jirani wake akapata nguo zao zilikuwa zimeangusha chini na kimbunga kwa sababu ya manyunyuyu ya mvuailiyokuwa inatishia kunyesha.**Dalili ya mvua ni mawingu** ni kweli kulingana na mababu zetu.Mzee alizinyakua nguo na kuanza kukimbia akiwa nazo kwa bega lake . **siku za mwizi ni Arubaini** kama waswahili wanavyosema . Mzee huyu alikamatwa na nguo hizi na akapigwa vizuri sana kiasi kwamba aliachwa akilia kama mtoto wa mwezi mmoja. Kwa kweli **majuto ni mjukuu** , mzee aliendelea kukumbuka zile siku alikuwa anauza ndizi na mahindi na kwenda kulewa. Sasa analia kwi kwi kwi na majirani wanamcheka kwa kwa kwa! Kweli kweli maisha ni magumu na dunia ni **uwanja wa fujo.** Mzee alisamu roho baada ya kuchomwa na peteroli na watoto wa jirani kwa sababu ya wizi wake.

Kwa upande wa vijana yaani wale wavulana watano wa mzee, waliposikia habari hii inayohuzunisha, walikimbia nyumbani kupanga mazishi ya mzee wao. Walimzika na baadaye , wakaanza kuuza shamba la mzee huyu marehemu ili wapate pesa za kumbe walikuwa wameanza kutumia madawa ya kulevya.Eeeeeh! **Asiyefunzwa na mamake hufunzwa na ulimwengu,** walipouza shamba la eka sita wakakimbilia madawa ya kulevya lakini kwa bahati mbaya wakashikwa na polisi wakinywa madawa na kupelekwa kotini na kufungwa kifungu cha miaka thelathini kila mvulana. Maisha yao yakaishia hapo.

**Maswali**

i) Ni kwa nini kulikuwa na kiangazi cha muda mrefu wilayani Isingiro?

.....  
.....  
.....  
.....

ii) Kulingana na aya ya pili, unafikiri ni nini kilikuwa chanzo cha matatizo katika familia yam zee Kazimoto?

Downloaded from www.mtotoonline.com, More PASTPAPERS are available

.....  
.....  
.....  
.....

iii) Kulingana na wewe, unafikiri hali hii ya anga inaweza kuwa ilisababishwa nini ? Eleza kwa maoni yako.

.....  
.....  
.....

Unajifunza nini katika hadithi hii wewe kama kijana?

.....  
.....  
.....  
.....

iv) Taja methali angalau tano ambazo mwandishi ametumia kupitisha ujumbe wake.

.....  
.....  
.....

v) Msimulizi anaposema “asiyefunzwa na mamake hufunzwa na ulimwengu” unapata maana gani kulingana na hadithi?

.....  
.....

**ITEM 2. Soma dondoo hili kwa makini kisha ujibu maswali.**

**Mchezo unaanzia kwa nyumba ya Bidii na Fala. Bwana Bidii yuko nyumbani na mkewe Fala.**

**Bidii:** kila siku nakwambia usirudi kwa maisha lakini utapata kilichomzuia ng’ombe kupaa.

**Fala:** Baba wa watoto wangu nimesikia naomba radhi mpenzi.

**Bidii:** Juzi nilienda shuleni kutembeleamtoto wangu Yule msichana mrefu. Unajua nini?

Kwani unajua? Lakini unajua nini?

**Fala:** Niambie tafadhali, mtoto wangu msichana hali vipi? sielewi mbona?

**Bidii:** Nitakwambia, ngoja kidogo.

**Fala:** Unajua ngoja ngoja huumiza matumbo? Sasa nielezee tafadhali.....

**Bidii:** Unajua jisichana lako limepata jivulana, sasa mwalimi mkuu aliwapata kinagaubaga darasani kama wakiga wasemavyo kuwa “macho ya mukiga ni kujionea mwenyewe” eeeeeh! Usiniambie tena kuhusu Malaya huyo.

**Fala:** wangi! wangi! eeh! Eeh what? Lakini mpenzi wangu nini? Njoooooooooooo

**Bidii:** Kuanzia leo usiniambie tena huyo Malaya wako, si mtoto wangu tena! Umesikia? Umesikia?

“Asiyefunzwa na mamake hufunzwa na ulimwengu” niache wewe!

**Fala** (kama amechanganyikiwa humo nyumbani) Mungu wangu! Mungu wangu!

**Anaanza kuimba**

**Dunia nzito kwangu aaaah**

**Unazaa mtoto wako aaaah**

**Shida duniani kote aaaaah**

**Mungu nisamehe aaaah**

**Hapana hapana sasa aaaah**

**Baba kanitusi aaaah**

**Juu ya watoto aaaah**

**Mungu! Mungu! Mungu weeeeeeeeeee**

**Bidii:** (anapata kama Fala anaimba na kujificha) Fala we uko wapi? Chakula kiko wapi? Juzi tumelalia mate, na leo tumbo liko uchi kwani huwezi kuacha familia yangu nilete yule Mirembe!!!!

**Fala:** Baba wangu, nimekuwa shambani nikilima n, ndio nimerudi sasa ninajitayarisha kuanza kupika.

**Bidii:** Fala we! Wacha mchezo wako? Na maji ya kujirembesha yauzwa? Umeanza hata kunuka, jike lichafu la vaa nguo chafu pia, hapana hapana.

**Fala:** samahani idogo bwana, nitabadilisha

**Bidii:** Siku za mwizi ni arubaini na baada ya dhiki ni faraja. Siku moja utajuta.

**Fala:** Mafumbo kwangu, mpenzi ..... chakula tayari.

**Bidii:** Kesho tuna mgeni hapa, safisha nyumba yako tafadhali. Sitaki machozi hapa

**Fala:** Haya mzee.

**Bidii:** Nimeleta mgeni wangu hapa ndiye Mirembe mpendwa. (Ameshika boto ya pilsiner mkononi)

**Fala:** Karibu mgeni kwetu.

(Bidii anajaribu kumwingiza kwenye chumba cha mkewe Fala lakini Fala anakuja akikimbia)

Baba wa watoto wangu kuna nini? Kuna nini hapa? Waba different! Eeh hapana unaingizaje jike lako hapa kwa chumba changu?

**Bidii:** Unauliza nani? Mimi? Mimi? Haya usinizoe tena( anampiga kofi kwa shavu pya ! na nyingine pya! anaanguka chini puu!na kuanza kulia kwi kwi kwi!

**Fala:** Mama aliyenizaa hajanichoka! Ebu niende kwetu.

**Bidii:** Usirudi hapa, usirudi hapa! Kwa heri sana switi na mpenzi. Enda pia na virago vyako vyote.

**Fala:** Kwa heri mpenzii wanguu.....

(Fala anaenda kwa mamake mzazi na kesi na kila kitu akihemahema lakini anamwambia bwanake amsamehe.)

**Maswali.**

- a) Mchezo huu umekuwa katika mandhari yapi?
- b) Ni mbinu gani za lugha zimetumiwa katika dondoo? Toa mifano maridhawa.
- c) unajifunza nini kutoka dondoo?
  - d) Taja sifa za wahusika hawa
- i) Bidii
- ii) Fala
  - e) Unaposoma dondoo hili, unapata hisia gani? Eleza kwa utondoti.
  - f) Unawapa ushauri gani vijana ambao wanapanga kupata jiko kwa kurejelea dondoo hili?

**MWISHO**

336/1

KISWAHILI

PAPER 1

(INSHA NA UFUPISHO)

MOCK 2024

2HRS



# MEBU EXAMINATIONS CONSULT

Uganda Certificate Of Education

MOCK ASSESSMENTS 2024

LUGHA YA KISWAHILI

INSHA NA UFUPISHO

MUDA: SAA MBILI (2HRS)

## MAAGIZO KWA WATAHINIWA

Karatasi hii ina sehemu mbili **A** na **B**

Jibu **maswali mawili** kwa **ujumla**

Sehemu **A**, katika sehemu hii kuna maswali **mawili** chagua **moja**.

Sehemu **B** ni ya lazima kwa watahiniwa **wote**.



## SEHEMU A (INSHA)

### AMA

1. a) Kila wakati majengo ya shule hasa kwa madarasa mna karatasi na takataka ya aina nyingi ambayo huwa inatupwa hata na kwenye mazingira ya shule. Kila wakati mwalimu mkuu wenu huwaambia kutunza usafi wa mazingira lakini mnamtilia pamba kwa masikio. Wewe kama mwanafunzi mzuri, toa ujumbe mwafaka kwa shule hii kuhusu suala hili.

### AU

- b) Vijana wa kwetu si vijana tena. Kuanzia asubuhi kulewa chakali. Juzi askari wa polisi aliwapata kwenye kikundi wakila majani majani wakafungwa jela kwa siku mbili. Hali hii mbovu hapana. Ni ushauri gani unawapa vijana wanaotumia madawa haya wewe kama kijana.

## SEHEMU B (UFUPISHO)

2. Soma stori hii kisha uifupishe kwa maneno themanini (80).

Wanyama wa pori wanapendeza sana. Ona vile twiga hufanana, na Yule wa rangi mbili yaani pundamilia. Juzi Uganda kama nchi imeingiza pesa nyingi sana kutoka kwa utalii. Watalii walitoka katika nchi kama Uingereza, Ujerumani, Ufaransa na Uhispania.

Wanyama hawa wanaleta pesa nyingi sana katika uchumi wanachi. Watu wengi wamepata kazi mkiwemo vijana, wazee na watoto. Wanyama pia wanaeleza saa kwa kupiga kelele. Wanyama hawa wa pori wanaliwa na wengine kama nyama. Vilevile, pembe za ndovu na wanyama wengine hutusaidia kupata shinikizo tunazovalia kwa blauzi na shati.

Kuna wanyama wa nyumbani na ndege pia kama nguruwe, ng'ombe, punda, ngamia, mbuzi, sungurakuku, bata, batamzinga, mbwa, njiwa, jogoo na kondoo. Wanatupa nyama kama ng'ombe. Mbwa anasaidia na ulinzi kwa sababu hubweka bwe bwe. Jogoo hutusaidia kueleza saa, kuku hutupa vifaranga. Baada ya kuwauza wanatupa pesa kama kuku, mbuzi, na kadhalika. Wanyama hawa hutusaidia kuzawadi watu, kulipa mahali pamoja na kupatia mtu jina. Wanyama wa nyumbani wanatupa samadi baada ya kuoza, tunaitumia shambani. Tunaweza kula nyama bila kuchoka kila wakati.

Punda, ngamia na farasi hubeba mizigo na pia wanatusaidia katika usafiri wa watu kutoka sehemu moja hadi nyingine. Kondoo hutupa sufu ya kupamba wakati wa sherehe. Aidha, ndege kama kuku na bata wanataga mayai yaliyo na protein ya hali ya juu. Manyoya ya kuku yanasaidia kama pambo. Kinyaunyau anasaidia kufukuza panya nyumbani. Ni jambo la busara kila mtu kufuga wanyama au ndege nyumbani aweze kunufaika kwa njia moja au nyingine.

Wanyama hawa wote huharibu mashamba ya watu kupitia kukanyagana kula mimea. Huletea watu magonjwa. Hakuna kizuri kisicho na dosari kwa kweli wanyama na ndege nyumbani hupiga kelele kwa binadamu. Ingekuwa bora kila mtu kujihadhari na athari hasi za wanyama hawa na ndege ili watunufaisha sote kama wanauganda.

## MWISHO

NAME:..... INDEX NO:

--	--	--	--	--	--	--	--

SIGNATURE:.....

545/1

CHEMISTRY PAPER 1

(Theory)

AUGUST

MOCK 2024

Hours.



# MEBU EXAMINATIONS CONSULT

## Uganda Certificate Of Education

### MOCK ASSESSMENTS 2024

#### CHEMISTRY

#### PAPER 1 (Theory)

2 Hours

#### INSTRUCTIONS TO CANDIDATES:

- ✓ This paper consists of two sections **A** and **B**. It has **six** examination items
- ✓ Section **A** has **two COMPULSORY items**.
- ✓ Section **B** has two parts **I** and **II**. Answer one item from each part.
- ✓ Answers to section **A** must be written in the spaces provided while those of section **B** must be written on the answer booklets provided.
- ✓ Any additional items responded to will **NOT** be scored.

**SECTION A**

**Attempt all items in this Section**

Downloaded from [www.nuttoonline.com](http://www.nuttoonline.com), More PASTPAPERS are available

**ITEM 1**

After working the whole day in their garden. Mary and Annet complained of pain and headache, Mary decided to take tablets of acetaminophen (Panadol) which were available in her drawer. Annet took some juice extract from Aloe barbadensis miller (aloe vera) plant. After a few hours, Mary got relieved from the pain but Annet claimed the pain was still on.

**TASK;**

a. As a chemistry learner,

i. Point out the mistake Annet made when choosing the product. (02 scores)

.....  
.....

ii. Help Annet to understand how the product works. (03 scores)

.....  
.....  
.....  
.....  
.....  
.....  
.....  
.....  
.....  
.....

b). Advise the two ladies on the challenges associated with the use of the products. (04 scores)

.....  
.....  
.....  
.....  
.....  
.....  
.....  
.....  
.....  
.....  
.....

## ITEM 2

John, a resident of Wakikoola, a remote village in Buikwe district is disturbed by frequent rains due to a leaking house top. He is willing to work on his house without affecting the environment. He is aware that there are various materials on the hardware market for roofing his house. He also knows that in order for one to produce good quality roofing materials, he should select the right material with suitable qualities and properties. However, he is still confused with the choice of the materials to use and he has approached you for some advice.



### TASK;

Use your chemistry knowledge to;

a) Explain

i. The categories of the materials.

(02 scores)

.....

.....

ii. The suitability of the materials.

(03 scores)

.....

.....

.....

.....

.....

.....

.....

Downloaded from www.mutoonline.com, More PASTPAPERS are available:

(b).Advise John on the choice of the materials.

(04 scores)

Downloaded from www.mutoononline.com, More PASTPAPERS are available

**SECTION B**

**PART I**

**Attempt one item from this Part.**

**ITEM 3**

In many industries, sodium hydroxide is used to make wood pulp and paper, textiles, soaps and detergents and as a drain cleaner. To ensure that sodium hydroxide is readily available and at a cheaper cost, one of the managers of a textile industry is planning to set up a sodium hydroxide production plant. Unfortunately, the residents have raised concerns about its environmental effects and their valuable land about to be taken by the investor.



Downloaded from www.mtutooni.com, More PAST PAPERS are available

The science club in your school is also wondering how the production process of sodium hydroxide will be carried out. As a result, the chairperson of the club has appointed you to make a presentation to be published in one of the local newspaper.

**TASK;**

As a chemistry learner, prepare a brief message that you will deliver during the presentation.

(12 Scores)

**ITEM 4**

Grain Pulse limited is one of Uganda's leading phosphate fertilizer manufacturer. It uses sulphuric acid as the main raw material. In a bid to cut the costs on the high revenue imposed on importing the acid, the management has constructed a production unit to set up a sulphuric acid production plant with minimal environmental concerns. A certain village in Kasese district has been selected for the plant. However, some residents in the region claim that the plant will not benefit them at all.

The science club members in your school would like to know how the production process will be carried out. They are seeking for guidance prior to addressing the school assembly.



**TASK.**

As a chemistry learner, make a write up they will use while addressing the assembly. (12 Scores)

**Part II**

**Attempt one item from this Part.**

**ITEM 5**

People of Kigaragara village in Isingiro district can easily cross into Tanzania for charcoal business. Due to increase in population of this district, many natural forests have been cleared to provide charcoal for use as fuel and natural swamps have been reclaimed to create space for settlement. These happenings have left the district officials wondering. As a result, the government through the district officials is planning to create awareness to the people in Isingiro District through sensitization workshops organized in different villages.



**TASK;**

As a chemistry learner, prepare a short presentation you will deliver during the workshop when invited. (10 scores)

**ITEM 6**

Kagulu village in Buyende district is developing at a faster rate. Many of the recently existing swamps and forests are now filled with buildings. Stone quarrying is the order of the day among most of the locals in the village. Recently, the wells have started drying up and yet the little water available is not fresh. The few residents that practice crop husbandry also say that seasons have changed and this has caused famine in the area. All these happenings have left many of the residents wondering. A sensitization workshop is to be organized in the district by the government through National Environment Management Authority (**NEMA**).

**TASK;**

As chemistry learner, prepare a brief presentation you will deliver upon invitation. (10 scores)

**END**

**TEL.0709843314 & 0761762094**

**CONTACT US FOR THE MOST AMAZING AND POWERFULL ASSESSMENTS.**

Downloaded From [www.intoothline.com](http://www.intoothline.com), More PASTPAPERS are available